

DRIVE SOLUTIONS FOR ROTARY FEEDERS

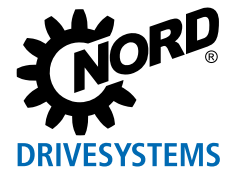

High availability for dosing and discharging: NORD DRIVESYSTEMS offers rotary feeder drive systems with integrated intelligent controllers that resolve most blockages automatically.

ROTARY FEEDERS FOR DISCHARGING AND DOSING OF BULK MATERIAL

For many applications e.g. continuous drying, mixing or milling an exact flow control of the material is mandatory for optimal results. Rotary feeders discharge bulk material (e.g. cement, ore, sugar, minerals, grains) from hoppers, silos, bunkers or cyclones. The handling of inhomogenous material occasionally causes a blockage in the feeding system – for maximum process efficiency, any blockage must be detected and resolved quickly. Doing this automatically requires an intelligent controller – most drives depend on an external PLC in the plant control room.

FREQUENCY INVERTER WITH INTEGRATED PLC FUNCTIONALITY TO REMOVE BLOCKAGES

Motor mounted NORD frequency inverter SK 200E features an integrated PLC. It is capable of detecting blockages and automatically alternating reverse / forward operation in order to break free. NORD DRIVESYSTEMS supplies the complete drive system comprising the gear unit, motor and pre-programmed frequency inverter. Due to the integrated reversing functionality, users do not need to program an external PLC to handle blockages. This not only reduces commissioning time, but also enables a very reliable feeder operation providing high process efficiency.

Integrated bus system
plug connectors



Modular system for
application-specific
solutions

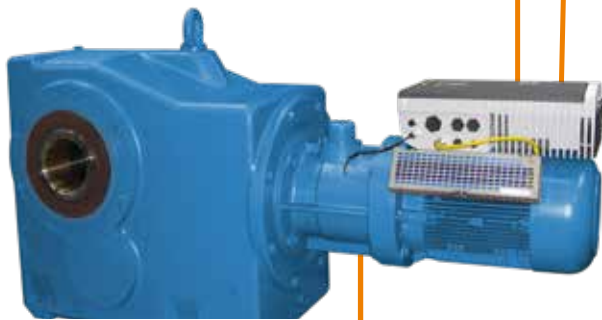

Torque-limiting
clutch

COMPLETE MECHATRONIC DRIVE SOLUTIONS FROM A SINGLE SOURCE

In this decentralized drive setup, signal interference is not an issue and running long screened cables is not required. Plug-and-Play power and bus system connectors greatly simplify installation and maintenance. This saves time and expenses.

DRIVE SOLUTIONS FOR ROTARY FEEDERS

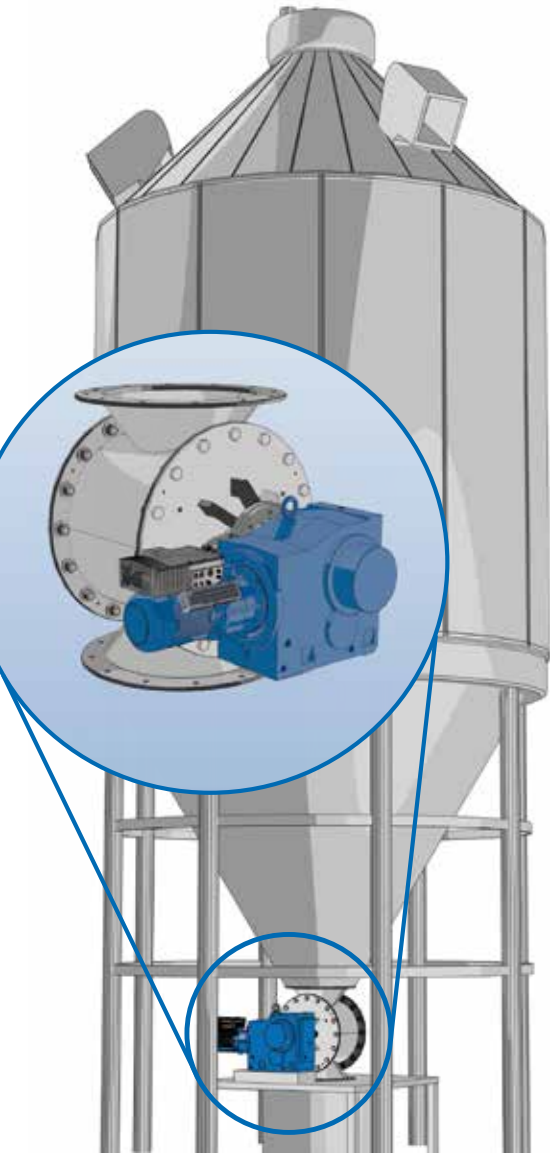

Typical graph of one reversing process

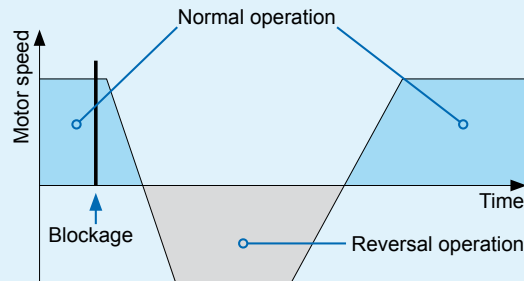

NORD Parameter Box
for installation and
diagnostics



KEY FEATURES

- Frequency inverter SK 200E with bevel gear motor
- Multi-plate torque-limiting clutch between motor and gear unit
- Overload detection by monitoring gearbox input shaft speed via two inductive sensors
- Inverter communicates directly with the sensors
- Automatic reversing
- Reversing process parameterization can be customized (see diagram on top of the page) to meet local process requirements
- 1x digital input (Start/Stop), 2x digital output (operation status and blockage) to control rotary feeder via external control system; alternatively: communication via various field bus systems (Profibus, Profinet, EtherNet/IP etc.)
- User-friendly power plug for easy mains connection and closed-loop inverter operation
- Maintenance switch at the device allows for servicing the system and enables safe manual removal of any blockage that cannot be automatically resolved

ADVANTAGES OF INVERTER WITH PRE-PROGRAMMED INTEGRATED PLC

- Motor mounted inverter with PLC minimizes installation effort (wiring)
- Easy commissioning and testing via local hand-held system (NORD Parameter Box); full functionality can be tested without external control system
- Internal NORD PLC comes pre-programmed, tested and ready for operation, which rules out configuration problems
- All reversing cycles and blocking events are logged to a permanent storage and can be read locally at any time



minerals.nord.com



www.sk200e.de

Contact your local NORD DRIVESYSTEMS representative or the Industry Sector Management Bulk & Minerals.

NORD DRIVESYSTEMS Group

- Family business from Bargteheide near Hamburg with 4,000 employees
- Drive solutions for more than 100 branches of industry
- 7 production locations worldwide
- Present in 98 countries on 5 continents
- More information: www.nord.com

Headquarters:

Getriebebau NORD GmbH & Co. KG

Getriebebau-Nord-Str. 1
22941 Bargteheide, Germany
T +49 4532 289 0, F +49 4532 289 2253
info@nord.com

Member of the NORD DRIVESYSTEMS Group