

INTELLIGENT DRIVESYSTEMS, WORLDWIDE SERVICES



BU 0185 – en

**NORDAC® BASE (SK 180E / SK 190E)**

Brief instructions for Frequency Inverters



## Documentation

<b>Title:</b>	<b>BU 0185</b>		
<b>Order – No.:</b>	<b>6071852</b>		
<b>Series:</b>	SK 1x0E		
<b>FI series:</b>	SK 180E, SK 190E		
<b>Device types:</b>	<i>SK 1x0E-250-112-O ... SK 1x0E-750-112-O</i>	0.25 – 0.75 kW,	1~ 110-120 V, Out: 230 V
	<i>SK 1x0E-250-323-B ... SK 1x0E-111-323-B</i>	0.25 – 1.1 kW,	1/3~ 200-240 V
	<i>SK 1x0E-151-323-B</i>	1.5 kW,	3~ 200-240 V
	<i>SK 1x0E-250-340-B ... SK 1x0E-221-340-B</i>	0.25 – 2.2 kW,	3~ 380-480 V

## Version list

Title, Date	Order number	Device software version	Remarks
<b>BU 0185</b> , June 2014	<b>6071852</b> / 2314	V 1.0 R1	First version based on BU 0180 DE / 2314
<b>BU 0185</b> , March 2015	<b>6071852</b> / 1315	V 1.0 R1	Revised version based on BU 0180 DE / 1315
<b>BU 0185</b> , March 2016	<b>6071852</b> / 1216	V 1.2 R0	Revised version based on BU 0180 DE / 1216
<b>BU 0185</b> , October 2018	<b>6071852</b> / 4118	V 1.2 R1	Revised version based on BU 0180 DE / 4118

Table 1: Version list

## Validity

The following brief instructions are based on the main instructions (see version list) of the relevant inverter series, which is also definitive for commissioning. These brief instructions summarise the information which is required for the basic commissioning of a standard drive technology application. Detailed information, especially with regard to parameters, options and special functions can be obtained from the latest versions of the main instructions for the frequency inverter as well as any supplementary instructions for field bus options (e.g. PROFIBUS DP) or inverter functionalities (e.g.: PLC).

## Copyright notice

As an integral component of the device described here, this document must be provided to all users in a suitable form.

Any editing or amendment or other utilisation of the document is prohibited.

## **Publisher**

**Getriebebau NORD GmbH & Co. KG**

Getriebebau-Nord-Straße 1 • 22941 Bargteheide, Germany • <http://www.nord.com/>  
Fon +49 (0) 45 32 / 289-0 • Fax +49 (0) 45 32 / 289-2253

**Member of the NORD DRIVESYSTEMS Group**



## Table of Contents

<b>1</b>	<b>General</b> .....	<b>7</b>
1.1	Overview .....	7
1.2	Safety, installation and operating instructions .....	8
1.3	Warning and hazard information .....	13
1.3.1	Warning and hazard information on the product.....	13
1.3.2	Warning and hazard information in the document .....	14
1.4	Standards and approvals .....	14
1.5	Type code / nomenclature.....	16
1.5.1	Name plate .....	16
1.5.2	Frequency inverter type code .....	17
1.6	Version in protection class IP55, IP66, IP69K.....	18
<b>2</b>	<b>Assembly and installation</b> .....	<b>19</b>
2.1	Installation SK 1x0E .....	19
2.1.1	Work procedures for motor installation .....	20
2.1.1.1	Adapters for different motors .....	21
2.2	Braking resistor (BW) - (from size 2).....	22
2.2.1	Internal braking resistor SK BRI4-.....	22
2.2.2	External braking resistor SK BRE4-... / SK BRW4-... / SK BREW4-.....	23
2.3	Electrical Connection .....	24
2.3.1	Wiring guidelines .....	24
2.3.2	Electrical connection of power unit .....	25
2.3.3	Electrical connection of the control unit .....	26
2.3.3.1	Control terminal details .....	28
2.4	Operation in potentially explosive environments .....	29
2.4.1	Operation in potentially explosive environments - ATEX zone 22 3D .....	29
2.4.1.1	Modification of the device for compliance with Category 3D .....	29
2.4.1.2	Options for ATEX Zone 22, category 3D .....	30
2.4.1.3	Maximum output voltage and torque reduction .....	32
2.4.1.4	Commissioning information .....	32
2.4.1.5	EU conformity declaration - ATEX .....	34
2.4.2	Operation in potentially explosive environments - EAC Ex.....	35
2.4.2.1	Modification of the device .....	35
2.4.2.2	Further Information .....	36
2.4.2.3	EAC Ex certificate .....	36
<b>3</b>	<b>Display, operation and options</b> .....	<b>37</b>
3.1	Control and parametrisation options .....	37
3.1.1	Control and Parametrisation Boxes / Software .....	38
3.1.2	Potentiometer adapter, SK CU4-POT.....	39
<b>4</b>	<b>Commissioning</b> .....	<b>40</b>
4.1	Factory settings.....	40
4.2	Starting up the device .....	41
4.2.1	Connection .....	41
4.2.2	Configuration .....	41
4.2.2.1	Parameterisation .....	41
4.2.2.2	DIP switches (S1, S2) .....	42
4.2.3	Commissioning examples.....	43
<b>5</b>	<b>Parameter</b> .....	<b>44</b>
5.1	Parameter overview .....	46
<b>6</b>	<b>Operating status messages</b> .....	<b>50</b>
6.1	Display of messages .....	50
6.2	Diagnostic LEDs on device .....	51
6.3	Messages.....	52
6.4	FAQ operational problems .....	59
<b>7</b>	<b>Technical data</b> .....	<b>61</b>
7.1	General data for frequency inverter.....	61

---

<b>8</b>	<b>Additional information</b> .....	<b>62</b>
<b>9</b>	<b>Maintenance and servicing information</b> .....	<b>63</b>
9.1	Maintenance Instructions .....	63
9.2	Service notes .....	64

## 1 General

### 1.1 Overview

This manual describes all of the possible functions and equipment. The equipment and functionality are limited according to the type of device.

#### Basic characteristics

- High starting torque and precise motor speed control setting by means of sensorless current vector control
- Can be installed directly on, or close to the motor.
- Permissible ambient temperature -25°C to 50°C (please refer to technical data)
- Integrated EMC mains filter for limit curve B, Category C1, motor-mounted (not with 115 V devices)
- Automatic measurement of stator resistance and determination of the exact motor data possible
- Programmable direct current braking
- Size 2 only: Built-in brake chopper for 4 quadrant operation, optional braking resistors (internal / external)
- 2 analogue inputs (switchable between current and voltage operation), which can also be used as digital inputs.
- 3 digital inputs
- 2 digital outputs
- Separate temperature sensor input (TF+/TF-)
- NORD system bus for connecting additional modules, with switchable terminating resistance and address which can be set using DIP switches.
- Four separate parameter sets, switchable online
- LEDs for diagnosis
- RS232/485 interface via RJ12 plug
- Operation of *three-phase current Asynchronous Motors* (ASM) and *Permanent Magnet Synchronous Motors* (PMSM)
- Integrated PLC ( [BU 0550](#))

#### Additional features of the SK 190E

- Integrated AS Interface

## 1.2 Safety, installation and operating instructions

Before working on or with the device, please read the following safety instructions extremely carefully. Please pay attention to all other information from the device manual.

Non-compliance can result in serious or fatal injuries and damage to the device or its surroundings.

**These safety instructions must be kept in a safe place!**

### 1. General

Do not use defective devices or devices with defective or damaged housings or missing covers (e.g. blind plugs for cable glands). Otherwise there is a risk of serious or fatal injuries caused by electric shock or bursting electrical components such as powerful electrolytic capacitors.

Unauthorised removal of covers, improper use, incorrect installation or operation causes a risk of serious personal injury or material damage.

During operation and depending on the protection class of the devices, there may be live, bare, moving or rotating parts or hot surfaces.

The device operates with a dangerous voltage. Dangerous voltage may be present at the supply lines, contact strips and PCBs of all connecting terminals (e.g. mains input, motor connection), even if the device is not working or the motor is not rotating (e.g. caused by electronic disabling, jamming of the drive or a short circuit at the output terminals).

The device is not equipped with a mains switch and is therefore always live when connected to the power supply. Voltages may therefore be connected to a connected motor at standstill.

Even if the drive unit has been disconnected from the mains, a connected motor may rotate and possibly generate a dangerous voltage.

If you come into contact with dangerous voltage such as this, there is a risk of an electric shock, which can lead to serious or fatal injuries.

The device and any power plug connectors must not be disconnected while a voltage is applied to the device. Failure to comply with this may cause arcing, which in addition to the risk of injury, also results in a risk of damage or destruction of the device.

The fact that the status LED or other indicators are not illuminated does not indicate that the device has been disconnected from the mains and is without voltage.

The heat sink and all other metal components can heat up to temperatures above 70 °C.

Touching these parts can result in local burns to the body parts concerned (cooling times and clearance from neighbouring components must be complied with).

All work on the device, e.g. transportation, installation, commissioning and maintenance work must be carried out by qualified experts (observe IEC 364 or CENELEC HD 384 or DIN VDE 0100 and IEC 664 or DIN VDE 0110 and national accident prevention regulations). In particular, the general and regional installation and safety regulations for work on high voltage systems (e.g. VDE) must be complied with as must the regulations concerning correct use of tools and the use of personal protection equipment.

During all work on the device, take care that no foreign bodies, loose parts, moisture or dust enter or remain in the device (risk of short circuit, fire and corrosion).

Further information can be found in this documentation.



## **2. Qualified experts**

For the purposes of these basic safety instructions, qualified personnel are persons who are familiar with the assembly, installation, commissioning and operation of this product and who have the relevant qualifications for their work.

Furthermore, the device and the associated accessories may only be installed and started up by qualified electricians. An electrician is a person who, because of their technical training and experience, has sufficient knowledge with regard to

- switching on, switching off, isolating, earthing and marking power circuits and devices,
- proper maintenance and use of protective devices in accordance with defined safety standards.

## **3. Correct purpose of use – general**

The frequency inverters are devices for industrial and commercial systems used for the operation of three-phase asynchronous motors with squirrel-cage rotors and Permanent Magnet Synchronous Motors – PMSM. These motors must be suitable for operation with frequency inverters, other loads must not be connected to the devices.

The devices are components intended for installation in electrical systems or machines.

Technical data and information for connection conditions can be found on the rating plate and in the documentation, and must be complied with.

The devices may only be used for safety functions which are described and explicitly approved.

CE-labelled devices fulfil the requirements of the Low Voltage Directive 2014/35/EU. The stated harmonized standards for the devices are used in the declaration of conformity.

### **a. Supplement: Correct purpose of use within the European Union**

When installed in machines, the devices must not be commissioned (i.e. commencement of proper use) until it has been ensured that the machine fulfils the provisions of EC Directive 2006/42/EC (Machinery Directive); EN 60204-1 must also be complied with.

Commissioning (i.e. start-up of proper use) is only permitted if the EMC directive (2014/30/EU) has been complied with.

### **b. Supplement: Correct purpose of use outside the European Union**

The local conditions of the operator for the installation and commissioning of the device must be complied with at the usage location (see also "a) Supplement: Correct purpose of use within the European Union").

## **4. Phases of life**

### ***Transport, storage***

The information in the manual regarding transport, storage and correct handling must be complied with.

The permissible mechanical and climatic ambient conditions (see technical data in the manual for the device) must be complied with.

If necessary, suitable, adequately dimensioned means of transport (e.g. lifting gear, rope guides) must be used.

**Installation and assembly**

The installation and cooling of the device must be implemented according to the regulations in the corresponding documentation. The permissible mechanical and climatic ambient conditions (see technical data in the manual for the device) must be complied with.

The device must be protected against impermissible loads. In particular, components must not be deformed and/or insulation distances must not be changed. Touching of electronic components and contacts must be avoided.

The device and its optional modules contain electrostatically sensitive components, which can be easily damaged by incorrect handling. Electrical components must not be mechanically damaged or destroyed.

**Electrical Connection**

Ensure that the device and the motor are specified for the correct supply voltage.

Installation, maintenance and repair work must not be carried out unless the device has been disconnected from the voltage and at least 5 minutes have elapsed since the mains was switched off! (Due to charged capacitors, the equipment may continue to carry hazardous voltages for up to 5 minutes after being switched off at the mains). Before starting work it is essential to check by measurement that all contacts of the power plug connections or the connection are voltage-free.

The electrical installation must be implemented as per the applicable regulations (e.g. cable cross-section, fuses, earth lead connections). Further instructions can be found in the documentation or manual for the device.

Information regarding EMC-compliant installation such as shielding, earthing, location of filters and routing of cables can be found in the documentation for the devices and in the technical information manual [TI 80-0011](#). CE marked devices must also comply with these instructions. Compliance with the limit values specified in the EMC regulations is the responsibility of the manufacturer of the system or machine.

In case of a fault, insufficient earthing may cause an electric shock with possibly fatal consequences if the device is touched.

The device may only be operated with effective earth connections which comply with local regulations for large leakage currents (> 3.5 mA). Detailed information regarding connections and operating conditions can be obtained from the technical Information manual [TI 80-0019](#).

The voltage supply of the device may directly or indirectly put it into operation, or touching electrically conducting components may then cause an electric shock with possible fatal consequences.

All phases of all power connections (e.g. power supply) must always be disconnected.

**Set-up, troubleshooting and commissioning**

When working on live devices, the applicable national accident prevention regulations must be complied with (e.g. BGV A3, formerly VBG 4).

The voltage supply of the device may directly or indirectly put it into operation, or touching electrically conducting components may then cause an electric shock with possible fatal consequences.

The parametrisation and configuration of the devices must be selected so that no hazards can occur.

With certain setting conditions, the device or the motor which is connected to it may start automatically when the mains are switched on. The machinery which it drives (press / chain hoist / roller / fan etc.) may then make an unexpected movement. This may cause various injuries, including to third parties.

Before switching on the mains, secure the danger area by warning and removing all persons from the danger area.

### **Operation**

Where necessary, systems in which the devices are installed must be equipped with additional monitoring and protective equipment according to the applicable safety requirements (e.g. legislation concerning technical equipment, accident prevention regulations, etc.).

All covers must be kept closed during operation.

With certain setting conditions, the device or the motor which is connected to it may start automatically when the mains are switched on. The machinery which it drives (press / chain hoist / roller / fan etc.) may then make an unexpected movement. This may cause various injuries, including to third parties.

Before switching on the mains, secure the danger area by warning and removing all persons from the danger area.

Due to its operation, the device produces noises within the audible frequency range. These noises may cause long-term stress, discomfort and fatigue, with negative effects on concentration. The frequency range or the noise can be shifted to a less disturbing or almost inaudible range by adjustment of the pulse frequency. However, this may possibly result in derating (lower power) of the device.

### **Maintenance, repair and decommissioning**

Installation, maintenance and repair work must not be carried out unless the device has been disconnected from the voltage and at least 5 minutes have elapsed since the mains was switched off! (Due to charged capacitors, the equipment may continue to carry hazardous voltages for up to 5 minutes after being switched off at the mains). Before starting work it is essential to check by measurement that all contacts of the power plug connections or the connection are voltage-free.

For further information, please refer to the manual for the device.

### **Disposal**

The product and its parts and accessories must not be disposed of as domestic waste. At the end of its life, the product must be properly disposed of according to the local regulations for industrial waste. In particular, this product contains integrated semiconductor circuits (PCBs and various electronic components, including high power capacitors). In case of incorrect disposal there is a risk of formation of toxic gases, which may cause contamination of the environment and direct or indirect injuries (e.g. chemical burns). In the case of high power capacitors, there is also a risk of explosion, with the associated risk of injury.

## **5. Potentially explosive environment (ATEX, EAC Ex)**

In order to operate or carry out installation work in potentially explosive environments (ATEX, EAC Ex), the device must be approved and the relevant requirements and notes from the manual of the device must be complied with.

Failure to comply can result in the ignition of an explosive atmosphere and fatal injuries.

- Only persons who are qualified, i.e. trained and authorised for all assembly, service, commissioning and operation work on association with explosion hazard environments may work with the devices described here (including the motors, geared motors, any accessories and all connection technology).





- Explosive concentrations of dust may cause explosions if ignited by hot or sparking objects. Such explosions may cause serious or fatal injuries to persons or severe material damage.
- The drive must comply with the specifications of "**Planning guideline for the operating and installation instructions B1091**" [B1091-1](#).
- Only original parts which are approved for the device and for operation in an explosion hazard area ATEX Zone 22 3D, EAC Ex must be used.
- **Repairs may only be carried out by Getriebebau NORD GmbH & Co. KG.**

### 1.3 Warning and hazard information

Under certain circumstances, hazardous situations may occur in association with the frequency inverter. In order to give explicit warning of possibly hazardous situations, clear warning and hazard information can be found on the device and in the relevant documentation.

#### 1.3.1 Warning and hazard information on the product

The following warning and hazard information is used on the product.

Symbol	Supplement to symbol <sup>1)</sup>	Meaning
	DANGER Device is live > 5min after removing mains voltage	<p><b>⚠ Danger</b> <b>Electric shock</b></p> <p>The device contains powerful capacitors. Because of this, there may be a hazardous voltage for more than 5 minutes after disconnection from the mains.</p> <p>Before starting work, check that the device is free of voltage at all power contacts by means of suitable measuring equipment.</p>
		It is essential to read the manual in order to prevent hazards!
		<p><b>⚠ CAUTION</b> <b>Hot surfaces</b></p> <p>The heat sink and all other metal components as well as the surfaces of plug connectors may heat up to temperatures in excess of 70°C.</p> <ul style="list-style-type: none"> <li>• Danger of injury due to local burns on contact.</li> <li>• Heat damage to adjacent objects</li> </ul> <p>Allow sufficient cooling time before starting work on the device. Check the surface temperatures with suitable measuring equipment. Maintain an adequate distance to adjacent components or provide protection against contact.</p>
		<p><b>NOTICE</b> <b>EDS</b></p> <p>The device contains electrostatically sensitive components, which can be easily damaged by incorrect handling.</p> <p>Avoid all contact (indirect contact by tools or similar, or direct contact) with PCBs and their components.</p>



1) Texts are written in English.

Table 2: Warning and hazard information on the product

### 1.3.2 Warning and hazard information in the document

The warning and hazard information in this document are located at the beginning of the section which describes the action which may result in the corresponding hazards.

The warning and hazard information is classified as follows according to the risk and the severity of the resulting injuries.

 <b>DANGER!</b>	Indicates an immediate danger, which may result in death or serious injury.
 <b>WARNING</b>	Indicates a possibly dangerous situation, which may result in death or serious injury.
 <b>CAUTION</b>	Indicates a possibly dangerous situation, which may result in slight or minor injuries.
<b>NOTICE</b>	Indicates a possibly harmful situation, which may cause damage to the product or the environment.

### 1.4 Standards and approvals

All devices of the entire SK 200E series comply with the standards and directives listed below.





Approval	Directive	Applied standards	Certificates	Code
CE (European Union)	Low Voltage Directive 2014/35/EU	EN 61800-5-1 EN 60529	C310400, C310401	
	EMC 2014/30/EU	EN 61800-3		
	RoHS 2011/65/EU	EN 50581		
UL (USA)		UL 61800-5-1	E171342	
CSA (Canada)		C22.2 No.274-13	E171342	
C-Tick (Australia)			N 23134	
EAC (Eurasia)	TR CU 004/2011, TR CU 020/2011	IEC 61800-5-1 IEC 61800-3	TC RU C- DE.A132.B.00000	

Table 3: Standards and approvals

Devices which are configured and approved for use in explosion hazard environments (  Section 2.4 "Operation in potentially explosive environments ") comply with the following directives and standards.



Approval	Directive	Applied standards	Certificates	Code
ATEX (European Union)	ATEX 2014/34/EU	EN 60079-0 EN 60079-31	C432410	
	EMC 2014/30/EU	EN 61800-5-1 EN 60529		
	RoHS 2011/65/EU	EN 61800-3 EN 50581		
EAC Ex (Eurasia)	TR CU 012/2011	IEC 60079-0 IEC 60079-31	TC RU C-DE.AA87.B.01109	

Table 4: Standards and approvals for explosion hazard environments

### 1.5 Type code / nomenclature

Unique type codes have been defined for the individual modules and devices. These provide individual details of the device type and its electrical data, protection class, fixing version and special versions. A differentiation is made according to the following groups:

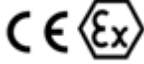

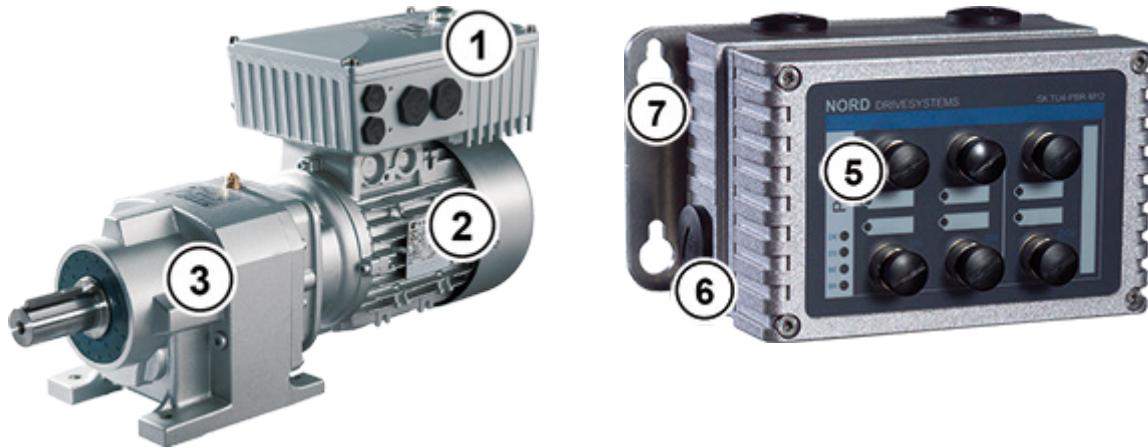
1	Frequency inverter
2	Motor
3	Gear units

5	Optional module
6	Connection unit
7	Wall-mounting kit

#### 1.5.1 Name plate

All of the information which is relevant for the device, including information for the identification of the device can be obtained from the type plate.



#### Legend

<b>Type:</b>	Type / designation
<b>Part No.:</b>	Part Number
<b>ID:</b>	Device ident number

<b>FW:</b>	Firmware version (x.x Rx)
<b>HW:</b>	Hardware version (xxx)

Figure 1: Name plate



### 1.5.2 Frequency inverter type code

SK 180E-370-323-B (-C) (-xxx)

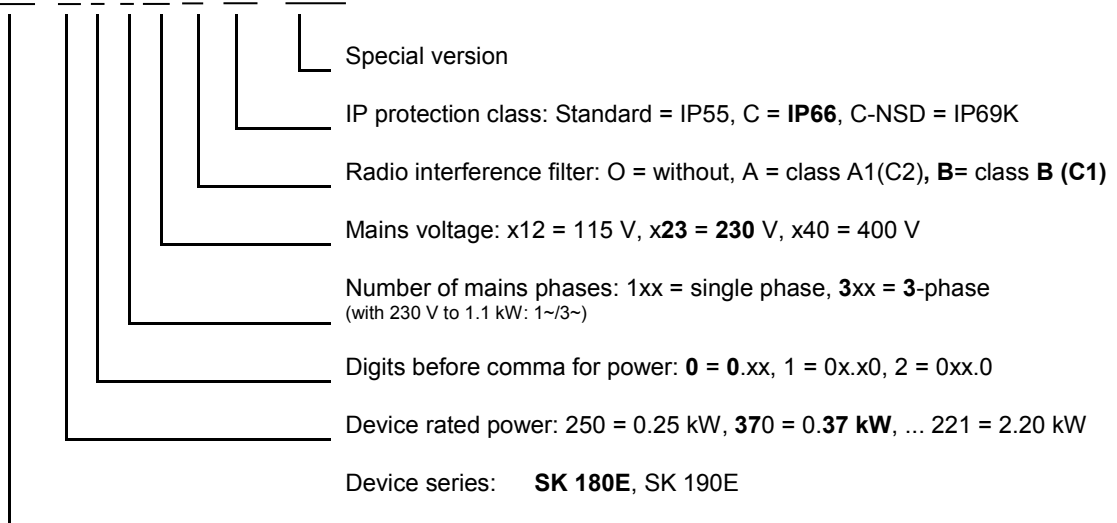

(...) Options, only implemented if required.

## 1.6 Version in protection class IP55, IP66, IP69K

The SK 1x0E is available in IP55 (standard) or IP66, IP69K (optional). The additional modules are available in protection classes IP55 (standard) or IP66 (optional).

A protection class that differs from the standard (IP66, IP69K) must always be specified in the order when ordering!

There are no restrictions or differences to the scope of functionality in the protection classes that have been mentioned. The type designation is extended accordingly in order to distinguish between the protection classes.

e.g. SK 1x0E-221-340-A-C

---

### Information

### Cable laying

For all versions, care must be taken that the cables and the cable glands at least comply with the protection class of the device and the attachment regulations and are carefully matched. The cables must be inserted so that water is deflected away from the device (if necessary use loops). This is essential to ensure that the required protection class is maintained.

#### IP55 version:

The IP55 version is the **standard** version. In this version, the two installation types *motor mounted* (fitted onto the motor) and *close coupled* (fitted to the wall bracket) are available. All adapter units, technology units and customer units are also available for this version.

#### IP66 version:

The IP66 version is a modified **option** of the IP55 version. Both installation types (*motor-integrated*, *close coupled*) are also available for this version. The modules available to the IP66 design (adapter units, technology units and customer units) have the same functionalities as the corresponding IP55 design modules.

---

### Information

### IP66 special measures

The modules for the IP66 version are identified by an additional "-C" in the type key, and are modified with the following special measures:

- impregnated PCBs,
- Powder coating RAL 9006 (white aluminium) for housing,
- modified blank screw caps (UV-resistant),
- Low pressure test.

#### IP69K version:

The IP69K version is a modified **option** of the IP66 version. In device with protection class IP69K, the housing is made from **nsd-tupH**. Both installation types (*motor-integrated*, *close coupled*) are also available for this version.

**Additional attachments (technology units etc.) to the device are not permitted.**

## 2 Assembly and installation

### 2.1 Installation SK 1x0E

The devices are available in various sizes depending on their output. They can be mounted on the terminal box of a motor or in its immediate vicinity.

Motor-mounted version

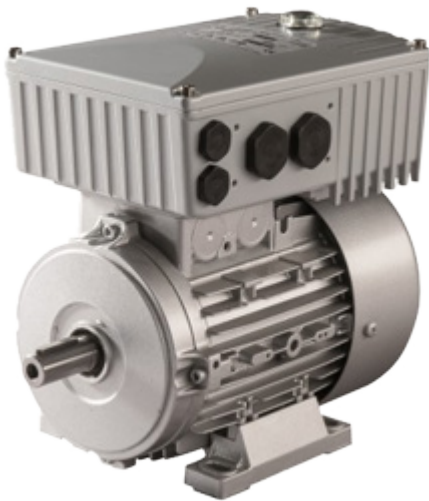

Wall-mounted version



When a complete drive unit (gear unit + motor + SK 1x0E) is delivered, the device is always fully installed and tested.

#### **i** Information

#### Device version IP6x

IP6x-compliant devices must be installed by NORD, since special measures have to be implemented. IP6x components that are retrofitted on site cannot ensure that this protection class is provided.

When delivered separately, the device includes the following components:

- SK 1x0E
- Screws and contact washers for mounting the motor terminal box
- Pre-fabricated cable for motor and PTC connections

#### **i** Information

#### Power derating

The equipment requires **sufficient ventilation** to protect against overheating. If this cannot be guaranteed, this results in power reduction (derating) of the frequency inverter. The ventilation is influenced by the type of installation (motor-mounting, wall-mounting) and/or with motor-mounting: the air flow of the motor fan (continuous slow speed → lack of cooling).

Insufficient cooling can result in power reduction of 1 - 2 power stages during S1 operation, for example, which can only be compensated for by using a nominally bigger device.

Details concerning output reduction and possible ambient temperatures, and other details ( Section 7 "Technical data").

### 2.1.1 Work procedures for motor installation

1. If necessary, remove the original terminal box from the NORD motor, so that only the base of the terminal box and the motor terminal strip remain.
2. Set the bridges for the correct motor circuit at the motor terminal strip, and connect the pre-fabricated cables for motor and PTC connections to the respective connection points on the motor.
3. Remove the casing cover from the SK 1x0E. To do this, undo 4 fastening screws and then remove the casing cover vertically from above.



4. Fit the casing of the SK 1x0E to the terminal box base of the NORD motor using the existing screws and seal as well as the provided toothed contact washers. When doing this, align the casing so that the rounded side is facing the direction of the A bearing cover of the motor. Carry out mechanical adaptation using the "Adapter kit" (📖 Section 2.1.1.1 "Adapters for different motors"). With motors made by other manufacturers, it must be checked whether they can be attached.

If necessary, the plastic cover (1) for the electronics must be carefully removed in order to make the screw fastenings to the base of the terminal box. Proceed with extreme caution when doing this to avoid damage to the exposed PCBs.

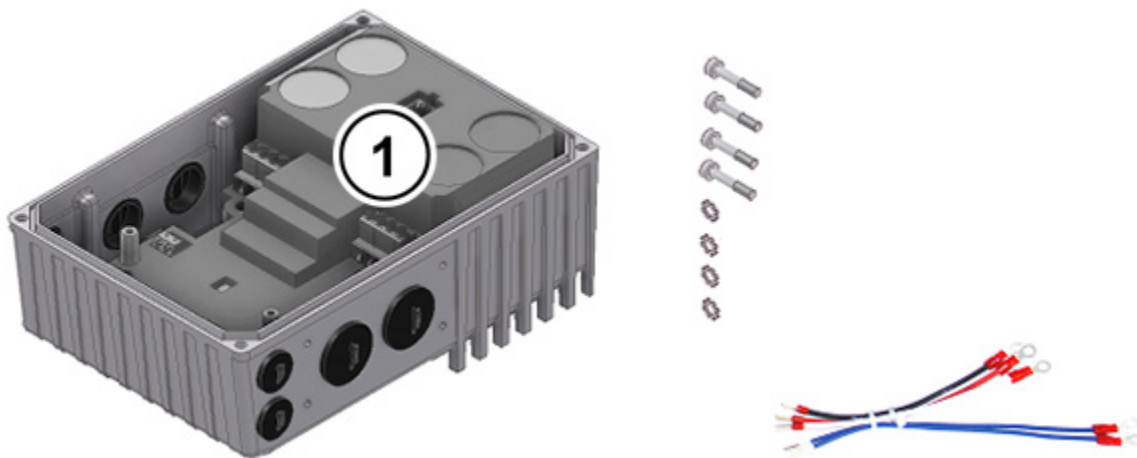

5. Make electrical connections. For the cable gland of the connecting cable, appropriate screwed connections for cable cross-section must be used.
6. Re-attach the casing cover. In order to ensure that the protection class for the device is achieved, care must be taken that all the fastening screws of the housing cover are tightened crosswise, gradually and with the torque specified in the table below.

The cable glands that are used must at least correspond to the protection class of the device.

Size SK 1x0E	Screw size	Tightening torque
Size 1	M5 x 25	3.5 Nm ± 20 %
Size 2	M5 x 25	3.5 Nm ± 20 %

### 2.1.1.1 Adapters for different motors

In some cases, the terminal box attachments are different for different motor sizes. Therefore, it may be necessary to use adapters to mount the device.

In order to ensure that the maximum IPxx protection class of the device is provided for the entire unit, all elements of the drive unit (e.g. motor) must correspond to at least the same protection class.

#### **i** Information

#### External motors

The adaptability of motors from other manufacturers must be checked individually!

Information about converting a drive to the device can be found in [BU0320](#).

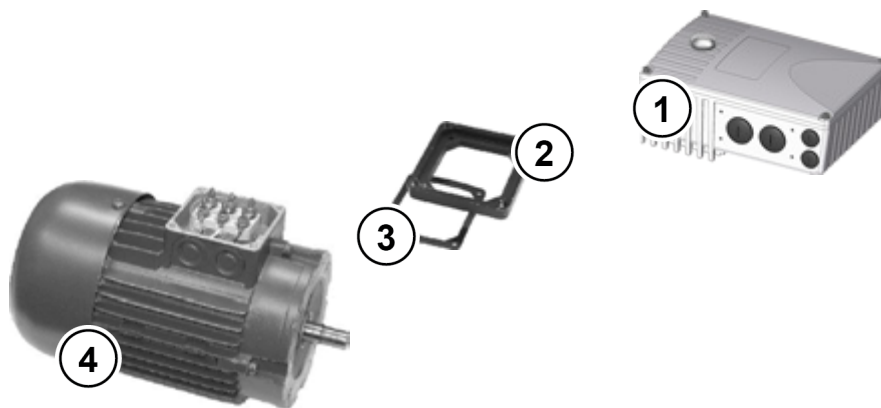

- 1 SK 1x0E
- 2 Adapter plate
- 3 Gasket
- 4 Motor, size 71

Figure 2: Example of motor size adaptation

NORD motor size	Attachment SK 1x0E size 1	Add-on SK 1x0E size 2
Size 63 – 71	with adapter kit I	with adapter kit I
Size 80 – 100	<i>Direct mounting</i>	<i>Direct mounting</i>

#### Overview of adapter kits

Adapter kit		Name	Components	Part No.
Adapter kit I	IP55	SK T14-12-Adapter kit_63-71	Adapter plate, terminal box frame seal and screws	275119050
	IP66	SK T14-12-Adapter kit_63-71-C		275274324

## 2.2 Braking resistor (BW) - (from size 2)

During dynamic braking (frequency reduction) of a three-phase motor, electrical energy is returned to the inverter if necessary. **From size 2 and above**, an internal or external braking resistor can be used to avoid a shut-down of the device due to overvoltage. With this, the integrated brake chopper (electronic switch) pulses the link circuit voltage (switching threshold approx. 420 V / 720 V<sub>DC</sub>, depending on mains voltage) into the braking resistor. The braking resistor converts excess energy into heat.

### **CAUTION**

#### Hot surfaces

The braking resistor and all other metal components can heat up to temperatures above 70°C.

- Danger of injury due to local burns on contact.
- Heat damage to adjacent objects

Allow sufficient cooling time before starting work on the product. Check the surface temperatures with suitable measuring equipment. Maintain an adequate distance to adjacent components or provide protection against contact.

### 2.2.1 Internal braking resistor SK BRI4-...

The internal braking resistor can be used if only slight, short braking phases are to be expected.



Similar to illustration

- The braking resistor **cannot be retrofitted** and must therefore be taken into account in the order.
- The output power of the braking resistor is limited and can be calculated as follows.

$$P = P_n * (1 + \sqrt{(30 / t_{brms})})^2, \text{ however, the following applies } P < P_{\max}$$

- (P=Brake power (W), P<sub>n</sub>= Continuous brake power of resistor (W), P<sub>max</sub>. peak brake power, t<sub>brake</sub> = duration of braking process (s))
- (For details of P<sub>n</sub> and P<sub>max</sub> see [BU0180](#))
- The permissible continuous brake power P<sub>n</sub> must not be exceeded in the long-term average.
- The peak and continuous powers must be limited by adjusting the parameter settings.

#### Required parameter settings

A braking resistor is installed by default in certain versions of the device. As delivered, the relevant parameters for limitation of the peak and continuous powers are pre-set (refer to the following tables).

### **NOTICE!**

#### Damage due to incorrect parameterisation

Incorrect settings of parameters (P555), (P556) and (P557) impair the correct function of the braking resistor and may destroy both this and the frequency inverter.

After setting the parameter "Factory Setting" (P523) to one of the functions 1, 2 or 3, it is essential to reset parameters (P555), (P556) and (P557) to the correct values.

Parameter number	Meaning	Setting [Unit]	Comments
P555	P - chopper limit	100 [%]	Power limit <sup>1)</sup>
P556	Braking resistor	200 [ $\Omega$ ]	Electrical resistance <sup>1)</sup>
P557	Braking resistor power	0.05 [kW]	Max. continuous power $P_n$ <sup>1)</sup>

1) of braking resistor

Parameter number	Meaning	Setting [Unit]	Comments
P555	P - chopper limit	65 [%]	Power limit <sup>1)</sup>
P556	Braking resistor	400 [ $\Omega$ ]	Electrical resistance <sup>1)</sup>
P557	Braking resistor type	0.05 [kW]	Max. continuous power $P_n$ <sup>1)</sup>

1) of braking resistor

### 2.2.2 External braking resistor SK BRE4-... / SK BRW4-... / SK BREW4-...

The external braking resistor is provided for energy feedback, e.g. as occurs in pulsed drive units or lifting gear. Here, it may be necessary to plan for the exact braking resistor that is required (see adjacent figure).

Installation of an SK BRE4-... is not possible in combination with the wall-mounting kit **SK TIE4-WMK...**. In this case, braking resistors of type **SK BREW4-...** are available as an alternative, which can also be fitted to the frequency inverter.



In addition **SK BRW4-...** type brake resistors are available for mounting on a wall near to the device.

#### Electrical data

Designation <sup>1)</sup> (IP67)	Resistance	Max. continuous power ( $P_n$ )	Energy consumption <sup>2)</sup> ( $P_{max}$ )
SK BRx4-1-100-100	100 $\Omega$	100 W	2.2 kW
SK BRx4-1-200-100	200 $\Omega$	100 W	2.2 kW
SK BRx4-1-400-100	400 $\Omega$	100 W	2.2 kW
SK BRx4-2-100-200	100 $\Omega$	200 W	4.4 kW
SK BRx4-2-200-200	200 $\Omega$	200 W	4.4 kW

1) SK BRx4-: versions: SK BRE4-, SK BRW4-, SK BREW4-  
2) Maximum once within 120s

#### Information

#### Braking resistor

If required, other versions or installation variants for external braking resistors can be provided.

## 2.3 Electrical Connection

### **WARNING**

### **Electric shock**

Dangerous voltages can be present at the mains input and the motor connection terminals even when the device is not in operation.

- Before starting work, check that all relevant components (voltage source, connection cables, connection terminals of the device) are free of voltage using suitable measuring equipment.
- Use insulated tools (e.g. screwdrivers).
- DEVICES MUST BE EARTHED.

### **Information**

### **Temperature sensor and PTC (TF)**

As with other signal cables, thermistor cables must be laid separately from the motor cables. Otherwise the interfering signals from the motor winding that are induced into the line affect the device.

Ensure that the device and the motor are specified for the correct supply voltage.

The housing cover must be removed from the device in order to make the electrical connection ( Section 2.1.1 "Work procedures for motor installation").

One terminal level is provided for the power connections and one for the control connections.

The PE connections (device earth) are located on the power connections for the motor and the mains, as well as on the base inside the cast housing.

The terminal strip assignments differ according to the version of the device. The correct assignment can be found on the inscription on the respective terminal or the terminal overview plan printed inside the device.

	Connecting terminals for
(1)	Power cable (X1.1)
(2)	Motor cable (X2.1)
(3)	Braking resistor lines (size 2 only)
(4)	Control lines (X4)
(5)	Control lines (X5) (SK 190E only)
(6)	PTC thermistor (TF) from motor (X3)
(7)	PE (X1.2 or X2.2)

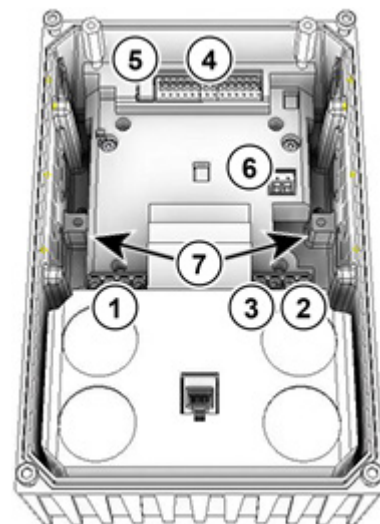

### 2.3.1 Wiring guidelines

The soft starters have been developed for use in an industrial environment. In this environment, electromagnetic interference can affect the device. In general, correct installation ensures safe and problem-free operation. To meet the limiting values of the EMC directives, the following instructions should be complied with.

1. Ensure that all devices are securely earthed to a common earthing point or earthing rail using short earthing cables with a large cross-section. It is especially important that each control unit which is connected to the electronic drive technology (e.g. an automatic device) has a short cable with a



large cross-section, which is connected to the same earthing point as the device itself. Flat cables (e.g. metal stirrups) are preferable, as they have a lower impedance at high frequencies.

2. The bonding cable of the motor controlled by the soft starter should be connected directly to the earthing terminal of the associated device. The presence of a central earthing bar in the control cabinet and the grouping together of all bonding conductors to this bar normally ensures safe operation.
3. Where possible, shielded cables should be used for control circuits. The shielding at the cable end should be carefully sealed and it must be ensured that the wires are not laid over longer distances without shielding.

The shields of analogue setpoint cables should only be earthed on one side on the device.

4. The control cables should be installed as far as possible from power cables, using separate cable ducts, etc. Where cables cross, an angle of 90° should be ensured as far as possible.
5. Ensure that the contactors in the cabinet are interference protected, either by RC circuits in the case of AC contactors or by free-wheeling diodes for DC contactors, for which **the interference traps must be positioned on the contactor coils**. Varistors for over-voltage limitation are also effective.
6. Shielded or armoured cables should be used for the load connections (motor cable if necessary). The shielding or armouring must be earthed at both ends. The earthing should be provided directly to the PE of the device if possible.

In addition, EMC-compliant wiring must be ensured.

**The safety regulations must be complied with under all circumstances when installing the devices!**

### NOTICE

#### Damage due to high voltage

The device may be damaged by electrical loads which do not correspond to its specification.

- Do not perform any high voltage tests on the device itself.
- Disconnect the cable which is to be tested from the device before performing a high voltage insulation test.

### Information

#### Looping of the mains voltage

The permissible current load for the connection terminals, plugs and supply cables must be observed when looping the mains voltage. Failure to comply with this will result in thermal damage to current-carrying modules and the immediate vicinity thereof.

If the device is installed according to the recommendations in this manual, it meets all EMC directive requirements, as per the EMC product standard EN 61800-3.

### 2.3.2 Electrical connection of power unit

### NOTICE

#### EMC Interference to the environment

This device produces high frequency interference, which may make additional suppression measures necessary in domestic environments ( [BU0180](#)).

The use of shielded motor cables is essential in order to maintain the specified radio interference suppression level.

When the device is being connected, please note the following:

1. Ensure that the mains supply provides the correct voltage and is suitable for the current required ( Section 7 "Technical data").
2. Ensure that suitable electrical fuses with the specified nominal current range are installed between the voltage source and the device.
3. Mains cable connection: to terminals **L1-L2/N-L3** and **PE** (depending on device)
4. Motor connection: to terminals **U-V-W**

A 4-core motor cable must be used if the device is being wall-mounted As well as **U-V-W**, **PE** must also be connected. If present, in this case the cable shielding must be connected to a large area of the metallic screw connector of the cable gland.

The use of wire end rings is recommended for connecting to PE.

**i Information** **Connection cables**

Only use copper cables with temperature class 80°C or equivalent for connection. Higher temperature classes are permissible.

When using **wiring sleeves**, the maximum connection cross-section can be reduced.

Device	Cable Ø [mm²]		AWG	Tightening torque	
	rigid	flexible		[Nm]	[lb-in]
1 ... 2	0.2 ... 4	0.2 ... 6	24-10	0.5 ... 0.6	4.42 ... 5.31
<b>Electromechanical brake</b>					
1 ... 2	0.2 ... 2.5	0.2 ... 2.5	24-14	0.5 ... 0.6	4.42 ... 5.31

Table 5: Connection data

**2.3.3 Electrical connection of the control unit**

**Connection data:**

Terminal bar		X3	X4, X5
Cable Ø *	[mm²]	0.2 ... 1.5	0.2 ... 1.5
Ø cable *	[mm²]	0.2 ... 0.75	0.2 ... 0.75
AWG standard		24-16	24-16
Tightening torque	[Nm]	0.5 ... 0.6	Clamping
	[lb-in]	4.42 ... 5.31	
Slotted screwdriver	[mm]	2.0	2.0

\* Flexible cable with wire-end ferrules, **without** plastic collar or rigid cable

\*\* Flexible cable with wire-end ferrules with plastic collar (for cable cross-section 0.75 mm², a wire-end ferrule with a length of 10 mm must be used)

The device generates its own control voltage and provides this to terminal 43 (e.g. for connection of external sensor systems).

**i Information** **Control voltage overload**

A control unit overload caused by impermissibly high currents may destroy the unit. Impermissibly high currents occur if the total current that is actually withdrawn exceeds the permissible total current.

The control unit can also be overloaded and destroyed if the 24 V DC supply terminals of the device are connected to a different voltage source For this reason, particularly when installing connectors for the control connection, it must be ensured that any cores for the 24 V DC power supply are not connected to the device but are insulated accordingly (example of connector for system bus connection SK TIE4-M12-SYSS).

**i Information** **Total currents**

If necessary, 24 V can be drawn from several terminals. This also includes e.g. digital outputs or an operating module connected via RJ45

The total current which is drawn off must not exceed 150 mA.

---

**i** **Information****Reaction time of digital inputs**

The reaction time of a digital signal is approx. 4-5 ms and consists of the following:

Scan time	1 ms
Signal stability check	3 ms
Internal processing	< 1 ms

---

**i** **Information****Cable laying**

All control cables (including thermistors) must be routed separately from the mains and the motor cables to prevent interference in the device.

If the cables are routed in parallel, a minimum distance of 20 cm must be maintained from cables which carry a voltage of > 60 V. The minimum distance may be reduced by screening the cables which carry a voltage, or by the use of earthed metal partitions within the cable conduits.

Alternative: Using a hybrid cable with shielding of the control lines.

---

### 2.3.3.1 Control terminal details

#### Labelling, function

AIN:	Analogue input	DO:	Digital output
ASI+/-:	Integrated AS interface	DIN:	Digital input
10 V:	10 V DC reference voltage for AIN	SYS+/-:	System bus
24 V:	24 V DC control voltage	TF+/-:	Motor thermistor (PTC) connection
GND:	Reference potential for analogue and digital signals		

#### Connections depending on the development stage

##### Terminal X3:

Device type		SK 180E	SK 190E ASI
Pin	Labelling		
1	39	TF-	
2	38	TF+	

##### Terminal X4

Device type		SK 180E	SK 190E ASI
Pin	Labelling		
1	11	10V	
2	14	AIN1	
3	16	AIN2	
4	40	GND	
5	43	24V (output)	
6	21	DIN1	
7	22	DIN2	
8	23	DIN3	
9	1	DO1	
10	40	GND	
11	3	DO2	
12	40	GND	
13	77	SYS+	
14	78	SYS-	

##### Terminal X5 (only SK 190E):

Device type		SK 180E	SK 190E ASI
Pin	Labelling		
1	84		ASI+
2	85		ASI-

### 2.4 Operation in potentially explosive environments

#### WARNING

#### Danger of explosion due to electricity



Electric sparks may ignite an explosive atmosphere.

- Do not open the device in an explosive atmosphere and do not remove any covers (e.g. diagnostic openings).
- All work on the device must only be carried out with the **power to the system switched off**.
- Wait for the required time ( $\geq 30$  min) after switching off.
- Before starting work, check that all relevant components (voltage source, connection cables, connection terminals of the device) are free of voltage using suitable measuring equipment.

#### WARNING

#### Explosion hazard due to high temperatures



High temperatures may cause the ignition of an explosive atmosphere.

Temperatures may occur within the device and the motor, which are higher than the maximum permissible surface temperature of the housing. Dust deposits may restrict the cooling of the device.

- Clean the device at regular intervals to prevent the accumulation of impermissible dust deposits.
- Do not open or remove the device from the motor in an explosive atmosphere.

With appropriate modification, the device can be used in certain potentially explosive areas.

If the device is connected to a motor and a gear unit, the EX labelling of the motor and the gear unit must also be observed. Otherwise the drive must not be operated.

#### 2.4.1 Operation in potentially explosive environments - ATEX zone 22 3D

All of the conditions which must be observed for operation of the frequency inverter in an explosion hazard environment (ATEX) are listed below.

##### 2.4.1.1 Modification of the device for compliance with Category 3D

Only a specially modified device is permissible for operation in ATEX zone 22. This adaptation is only made at the NORD factory. In order to use the device in ATEX Zone 22, the diagnostic caps are replaced with aluminium / glass versions, among other things.



( 1 ) Year of manufacture

( 2 ) Marking of the device (ATEX)

IP55: II 3D Ex tc IIB T125 °C Dc X

IP66: II 3D Ex tc IIC T125 °C Dc X

**Categorisation:**

- Protection with "housing"
- Procedure "A" Zone "22" Category 3D
- Protection class IP55 / IP66 (according to the device)
  - IP66 is required for conductive dust
- Maximum surface temperature 125°C
- Ambient temperature -20°C to +40°C

**i Information**

**Potential damage**

Devices in series SK 1x0E and the permitted options are only designed for a degree of mechanical stress that corresponds to a low impact energy of 7J.

Higher loads will lead to damage to or in the device.

The necessary components for making adaptations are contained in the ATEX kits.

Device	Kit designation	Part Number	Quantity	Document
SK 1x0E-... (IP55)	SK 1xxE-ATEX-IP55	275274207	1	<a href="#">TI 275274207</a>
SK 1x0E-...-C (IP66)	SK 1xxE-ATEX-IP66	275274208	1	<a href="#">TI 275274208</a>

**2.4.1.2 Options for ATEX Zone 22, category 3D**

In order to ensure that the device is ATEX-compliant, its optional modules must also be approved for potentially explosive areas. Option modules that are not in the following list may **not** be used in an ATEX zone 22 3D. This also includes connectors and switches that may also not be used in such an environment.

**Control and parametrisation units** are basically **not** approved for **operation in ATEX zone 22 3D**. They may therefore only be used for commissioning or maintenance purposes and if it has been ensured that no explosive dust atmosphere exists.

Designation	Part Number	Use permitted
<b>Braking resistors</b>		
SK BRI4-1-100-100	275272005	Yes
SK BRI4-1-200-100	275272008	Yes
SK BRI4-1-400-100	275272012	Yes

Bus interfaces		
SK CU4-CAO(-C)	275271001 / (275271501)	Yes
SK CU4-DEV(-C)	275271002 / (275271502)	Yes
SK CU4-ECT(-C)	275271017 / (275271517)	Yes
SK CU4-EIP(-C)	275271019 / (275271519)	Yes
SK CU4-PBR(-C)	275271000 / (275271500)	Yes
SK CU4-PNT(-C)	275271015 / (275271515)	Yes
SK CU4-POL(-C)	275271018 / (275271518)	Yes
IO -Extensions		
SK CU4-IOE(-C)	275271006 / (275271506)	Yes
SK CU4-IOE2(-C)	275271007 / (275271507)	Yes
SK CU4-REL(-C)	275271011 / (275271511)	Yes
Potentiometers		
SK ATX-POT	275142000	Yes
Miscellaneous		
SK CU4-FUSE(-C)	275271122 / (275271622)	Yes
SK CU4-MBR(-C)	275271010 / (275271510)	Yes
Wall mounting kits		
SK TIE4-WMK-1-EX	275175053	Yes
Adapter kits		
SK TI4-12-Adapter kit_63-71-EX	275175038	Yes

### SK ATX-POT

The Category 3D frequency inverter can be equipped with an ATEX-compliant 10 k $\Omega$  potentiometer (SK ATX-POT), which can be used to setpoint (e.g. speed) adjustment on the device. The potentiometer is used with an M20-M25 extension in one of the M25 cable glands. The selected setpoint can be adjusted with a screwdriver. Due to the detachable screw closing cap, this component complies with ATEX requirements. Permanent operation may only be carried out with the cap closed.

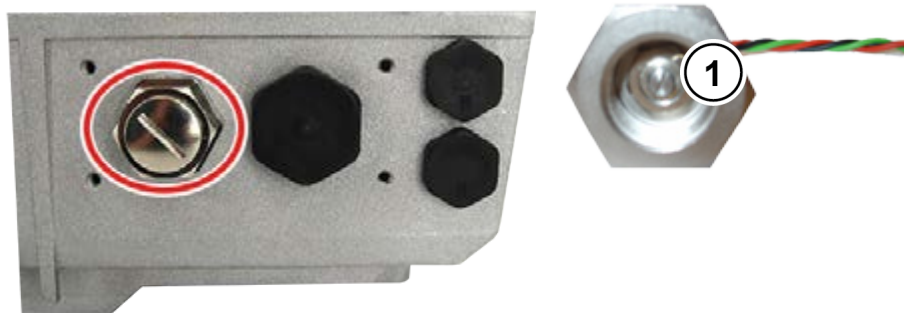

1 Setting adjustment using a screwdriver

SK ATX-POT wire colour	Name	Terminal SK CU4-24V...	Terminal SK CU4-IOE	Terminal SK 1x0E
red	+10 V reference	[11]	[11]	[11]
black	AGND / 0V	[12]	[12]	[12] / [40]
green	Analogue input	[14]	[14] / [16]	[14] / [16]

## **i** Information

### Internal braking resistor "SK BRI4-..."

If an internal braking resistor of type SK BRI4-x-xxx-xxx is used, the power limitation for this must be activated under all circumstances  Section 2.2.1 "Internal braking resistor SK BRI4-...". Only the resistors assigned to the relevant inverter type may be used.

#### 2.4.1.3 Maximum output voltage and torque reduction

As the maximum achievable output voltage depends on the pulse frequency to be set, in some cases the torque which is specified in document [B1091-1](#) must be reduced for values above the rated pulse frequency of 6 kHz.

For  $F_{\text{pulse}} > 6 \text{ kHz}$ :  $T_{\text{reduction}}[\%] = 1 \% * (F_{\text{pulse}} - 6 \text{ kHz})$

Therefore the maximum torque must be reduced by 1 % for each kHz pulse frequency above 6 kHz. The torque limitation must be taken into account on reaching the break frequency. The same applies for the degree of modulation (P218). With the factory setting of 100 %, in the field reduction range a torque reduction of 5 % must be taken into account:

For  $P218 > 100 \%$ :  $T_{\text{reduction}}[\%] = 1 \% * (105 - P218)$

Above a value of 105 %, no reduction needs to be taken into account. However, with values above 105 % no increase in torque above that of the Planning Guideline will be achieved. Under certain circumstances, degrees of modulation  $> 100 \%$  may lead to oscillations and motor vibration due to increased harmonics.

## **i** Information

### Power derating

At pulse frequencies above 6 kHz (400 V devices) or 8 kHz (230 V) devices, the reduction in power must be taken into account for the design of the drive unit.

If parameter (P218) is set to  $< 105 \%$ , the derating of the degree of modulation must be taken into account in the field reduction range.

#### 2.4.1.4 Commissioning information

For Zone 22 the cable glands must at least comply with protection class IP55. Unused openings must be closed with blank screw caps that are suitable for ATEX Zone 22 3D (generally IP 55).

The motors are protected from overheating by the device. This takes place by means of evaluation of the motor PTC (TF) at the device side. In order to ensure this function, the PTC must be connected to the intended input (Terminal 38/39).





In addition, care must be taken that a NORD motor from the motor list (P200) is set. If a standard 4-pole NORD motor or a motor from a different manufacturer is not used, the data for the motor parameters ((P201) to (P208)) must be adjusted to those on the motor rating plate. *The stator resistance of the motor (see P208) must be measured by the inverter and at ambient temperature. In order to do this, parameter P220 must be set to "1".* In addition, the frequency inverter must be parameterised so that the motor can be operated with a maximum speed of 3000 rpm. For a four-pole motor, the "maximum frequency" must be set to a value which is smaller or equal to 100 Hz ((P105)  $\leq 100$ ). Here the maximum permissible output speed of the gear unit must be observed. In addition, the monitoring "I<sup>2</sup>t-Motor" (Parameter (P535) / (P533)) must be switched on and the pulse frequency set to between 4 kHz and 6 kHz.



### Overview of required parameter settings:

Parameter	Setting value	Factory setting	Description
P105 Maximum frequency	≤ 100 Hz	[50]	This value relates to a 4-pole motor. On principle, the value must only be so large that a motor speed of 3000 rpm is not exceeded.
P200 Motor list	Select appropriate motor power	[0]	If a 4-pole NORD motor is used, the pre-set motor data can be called up.
P201 – P208 Motor data	Data according to rating plate	[xxx]	If a 4-pole NORD motor is not used, the motor data on the rating plate must be entered here.
P218 Degree of modulation	≥ 100%	[100]	Determines the maximum possible output voltage
P220 Parameter identification	1	[0]	Measures the stator resistance of the motor. When the measurement is complete, the parameter is automatically reset to "0". The value that is determined is written to P208
P504 Pulse frequency	4 kHz ... 6 kHz	[6]	For pulse frequencies above 6 kHz a reduction of the maximum torque is necessary.
P533 Factor I <sup>2t</sup> -Motor	< 100%	[100]	A reduction in torque can be taken into account with values less than 100 in the I <sup>2t</sup> monitoring.
P535 I <sup>2t</sup> motor	According to motor and ventilation	[0]	The I <sup>2t</sup> - monitoring of the motor must be switched on. The set values depend on the type of ventilation and the motor used. See <a href="#">B1091-1</a>

2.4.1.5 EU conformity declaration - ATEX

<p><b>GETRIEBEBAU NORD</b> Member of the NORD DRIVESYSTEMS Group</p>																			
<p>Getriebebau NORD GmbH &amp; Co. KG Getriebebau-Nord-Str. 1 · 22941 Bargteheide, Germany · Fon +49(0)4532 289 - 0 · Fax +49(0)4532 289 - 2253 · info@nord.com <span style="float: right;">C432410_1418</span></p>																			
<p><b>EU Declaration of Conformity</b> In the meaning of the EU directives 2014/34/EU Annex X, 2014/30/EU Annex II and 2011/65/EU Annex VI</p>																			
<p>Getriebebau NORD GmbH &amp; Co. KG as manufacturer in sole responsibility hereby declares, <span style="float: right;">Page 1 of 1</span> that the variable speed drives of the product series</p> <ul style="list-style-type: none"> <li>• SK 180E-xxx-123-B-.. , SK 180E-xxx-323-B-.. , SK 180E-xxx-340-B-..</li> <li>• SK 190E-xxx-123-B-.. , SK 190E-xxx-323-B-.. , SK 190E-xxx-340-B-.. (xxx= 250, 370, 550, 750, 111, 151, 221)</li> </ul> <p>and the further options/accessories: SK CU4-PBR, SK CU4-CAO, SK CU4-DEV, SK CU4-PNT, SK CU4-ECT, SK CU4-POL, SK CU4-EIP, SK CU4-IOE, SK ATX-POT, SK BRI4-1-200-100, SK BRI4-1-400-100, SK TIE4-WMK-1, SK TIE4-M12-M16</p> <p>with ATEX labeling </p> <p>comply with the following regulations:</p> <table style="width: 100%; border: none;"> <tr> <td style="width: 30%;"><b>ATEX Directive for products</b></td> <td style="width: 30%;"><b>2014/34/EU</b></td> <td style="width: 40%;">OJ. L 96 of 29.3.2014, P. 309–356</td> </tr> <tr> <td><b>EMC Directive</b></td> <td><b>2014/30/EU</b></td> <td>OJ. L 96 of 29.3.2014, P. 79–106</td> </tr> <tr> <td><b>RoHS Directive</b></td> <td><b>2011/65/EU</b></td> <td>OJ. L 174 of 1.7.2011, P. 88–110</td> </tr> </table> <p><b>Applied standards:</b></p> <table style="width: 100%; border: none;"> <tr> <td style="width: 33%;">EN 60079-0:2012+A11:2013</td> <td style="width: 33%;">EN 60079-31:2014</td> <td style="width: 33%;">EN 61800-9-1:2017</td> </tr> <tr> <td>EN 61800-5-1:2007+A1:2017</td> <td>EN 61800-3:2004+A1:2012+AC:2014</td> <td>EN 61800-9-2:2017</td> </tr> <tr> <td>EN 60529:1991+A1:2000+A2:2013+AC:2016</td> <td>EN 50581:2012</td> <td></td> </tr> </table> <p>It is necessary to notice the data in the operating manual to meet the regulations of the EMC-Directive. Specially take care about correct EMC installation and cabling, differences in the field of applications and if necessary original accessories.</p> <p>First marking was carried out in 2015.</p> <p><b>Bargteheide, 06.04.2018</b></p> <div style="display: flex; justify-content: space-around; margin-top: 20px;"> <div style="text-align: center;">  <p>U. Küchenmeister Managing Director</p> </div> <div style="text-align: center;">  <p>pp F. Wiedemann Head of Inverter Division</p> </div> </div>		<b>ATEX Directive for products</b>	<b>2014/34/EU</b>	OJ. L 96 of 29.3.2014, P. 309–356	<b>EMC Directive</b>	<b>2014/30/EU</b>	OJ. L 96 of 29.3.2014, P. 79–106	<b>RoHS Directive</b>	<b>2011/65/EU</b>	OJ. L 174 of 1.7.2011, P. 88–110	EN 60079-0:2012+A11:2013	EN 60079-31:2014	EN 61800-9-1:2017	EN 61800-5-1:2007+A1:2017	EN 61800-3:2004+A1:2012+AC:2014	EN 61800-9-2:2017	EN 60529:1991+A1:2000+A2:2013+AC:2016	EN 50581:2012	
<b>ATEX Directive for products</b>	<b>2014/34/EU</b>	OJ. L 96 of 29.3.2014, P. 309–356																	
<b>EMC Directive</b>	<b>2014/30/EU</b>	OJ. L 96 of 29.3.2014, P. 79–106																	
<b>RoHS Directive</b>	<b>2011/65/EU</b>	OJ. L 174 of 1.7.2011, P. 88–110																	
EN 60079-0:2012+A11:2013	EN 60079-31:2014	EN 61800-9-1:2017																	
EN 61800-5-1:2007+A1:2017	EN 61800-3:2004+A1:2012+AC:2014	EN 61800-9-2:2017																	
EN 60529:1991+A1:2000+A2:2013+AC:2016	EN 50581:2012																		

### 2.4.2 Operation in potentially explosive environments - EAC Ex

All of the conditions which must be observed for operation of the frequency inverter in an explosion hazard environment according to EAC Ex are listed below. All of the conditions according to  Section 2.4.1 "Operation in potentially explosive environments - ATEX zone 22 3D "apply . Deviations which are relevant for approval according to EAC EX are described below and must be .complied with

#### 2.4.2.1 Modification of the device

 Section 2.4.1.1 "Modification of the device for compliance with Category 3D"applies.

The labelling of the device according to EAC Ex differs as follows.

#### Labelling of the device:

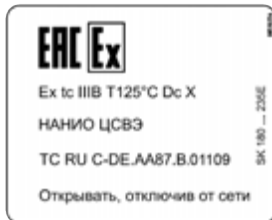

The following applies for wall mounted devices;

IP55: Ex tc IIIB T125 °C Dc X

IP66: Ex tc IIIC T125 °C Dc X



The following applies for motor mounted devices;

IP55: Ex tc IIIB Dc U

IP66: Ex tc IIIC Dc U

#### Categorisation:

- Protection with "housing"
- Procedure "A" Zone "22" Category 3D
- Protection class IP55 / IP66 (depending on the device)
  - IP66 is required for conductive dust
- Maximum surface temperature 125 °C
- Ambient temperature -20 °C to +40 °C

#### Information

#### Code "U"

Code "U" applies for frequency inverters which are intended for motor mounting. Devices which are so labelled are considered to be incomplete and may only be operated in combination with a corresponding motor. If a device which is coded "U" is mounted in a motor, the labels and restrictions which are marked on the motor or the geared motor also apply.

#### Information

#### Code "X"

The code "X" indicates that the permissible ambient temperature range is between -20°C and +40°C

### 2.4.2.2 Further Information

Further information regarding explosion protection can be found in the following sections.

Description	Section
"Options for ATEX Zone 22, category 3D"	2.4.1.2
"Maximum output voltage and torque reduction"	2.4.1.3
"Commissioning information"	2.4.1.4

### 2.4.2.3 EAC Ex certificate

[TC RU C-DE.AA87.B.01109](#)

## 3 Display, operation and options

### **WARNING**

### **Electric shock**

When devices are open, electrically conducting elements (e.g. connection terminals, connection cables, PCBs, etc.) are freely accessible. These may be live, even if the device has been switched off.

- Avoid all contact.

As supplied, without additional options, the diagnostic LED is externally visible. This indicates the actual status of the device. In contrast, the AS-i LED (SK 190E) is only visible if the device is open.

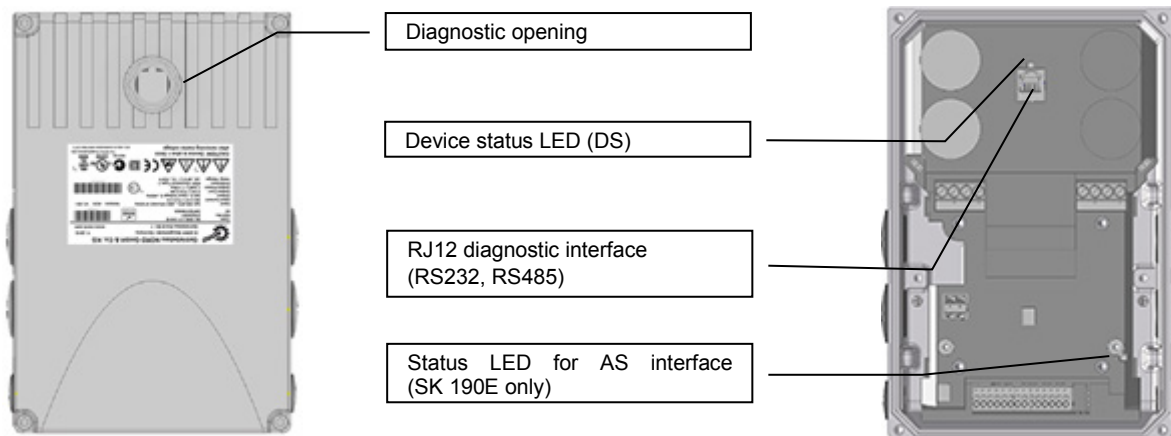

The device can be easily adapted to various requirements by using function-extending modules and modules for for display, control and parameterisation.

Alphanumeric display and control modules (📖 Section 3.1 "Control and parametrisation options ") can be used for simple commissioning by means of adapting parameters. For more complex tasks, connection to a PC system can take place with the aid of the NORDCON parameterisation software.

### 3.1 Control and parametrisation options

Various control options are available that can be fitted directly to the device or in close proximity to it and directly connected.

Parametrisation units also provide a facility for accessing the parametrisation of the device and adapting it.

Designation		Part Number	Document
<b>Switches and potentiometers</b> (attachment)			
SK CU4-POT	Switch/Potentiometer	275271207	📖 Section 3.1.2 "Potentiometer adapter, SK CU4-POT"
SK TIE4-POT	Potentiometer 0-10V	275274700	<a href="#">TI 275274700</a>
SK TIE4-SWT	Switch "L-OFF-R"	275274701	<a href="#">TI 275274701</a>
<b>Control and parametrisation boxes</b> (Handheld)			
SK CSX-3H	SimpleBox	275281013	<a href="#">BU0040</a>
SK PAR-3H	ParameterBox	275281014	<a href="#">BU0040</a>

### 3.1.1 Control and Parametrisation Boxes / Software

All parameters can be conveniently accessed for reading or editing by means of an optional SimpleBox or ParameterBox. The modified parameter data is stored in the non-volatile EEPROM memory.

Up to 5 complete device data sets can be stored in the ParameterBox and then retrieved.

The connection between the SimpleBox or the ParameterBox and the device is made with an RJ12-RJ12 cable.



Figure 3: SimpleBox, handheld, SK CSX-3H



Figure 4: ParameterBox, handheld, SK PAR-3H

Module	Description	Data
SK CSX-3H (handheld SimpleBox)	Used for commissioning, parameterisation, configuration and control of the device <sup>1)</sup> .	4-digit, 7-segment LED display, membrane keyboard IP20 RJ12-RJ12 cable (connection to the device <sup>1)</sup> )
SK PAR-3H (handheld ParameterBox)	Used for commissioning, parameterisation, configuration and control of the frequency inverter and its options (SK xU4-...). Entire parameter data sets can be stored.	2-line backlit LCD-display, membrane keyboard Stores up to 5 complete parameter data sets IP20 RJ12-RJ12 cable (connection to device) USB cable (connection to PC)
1)	does not apply to optional modules such as bus interfaces	

#### Connection

1. Remove diagnostics glass of RJ12 socket.
2. Connect the RJ12-RJ12 cable between the control unit and the frequency inverter.

*When a diagnostics glass or a blind plug is open, take care that no dirt or moisture enters the device.*

3. After commissioning, the **diagnostics glass or blind plugs must be screwed back in again** and it must be ensured that they are **tightly sealed** before starting regular operation.



#### Information

#### Diagnostic cap tightening torque

The tightening torque for the transparent diagnostic caps (inspection glasses) is 2.5 Nm.

#### 3.1.2 Potentiometer adapter, SK CU4-POT

The R and L digital signals can be directly applied to digital inputs 1 and 2 of the frequency inverter.

The potentiometer (0 - 10 V) can be evaluated via an analogue input of the frequency inverter, or via an I/O extension.



Module		SK CU4-POT	Connection: Terminal No.		Function
Pin	Colour		SK 1x0E	FI	
1	brown	24V-supply voltage	43		Rotary switch L - OFF - R
2	black	Enable R (e.g. DIN1)	21		
3	white	Enable L (e.g. DIN2)	22		
4	white	Access to AIN1+	14		Potentiometer 10 kΩ
5	brown	Reference voltage 10V	11		
6	blue	Analogue ground AGND	12		

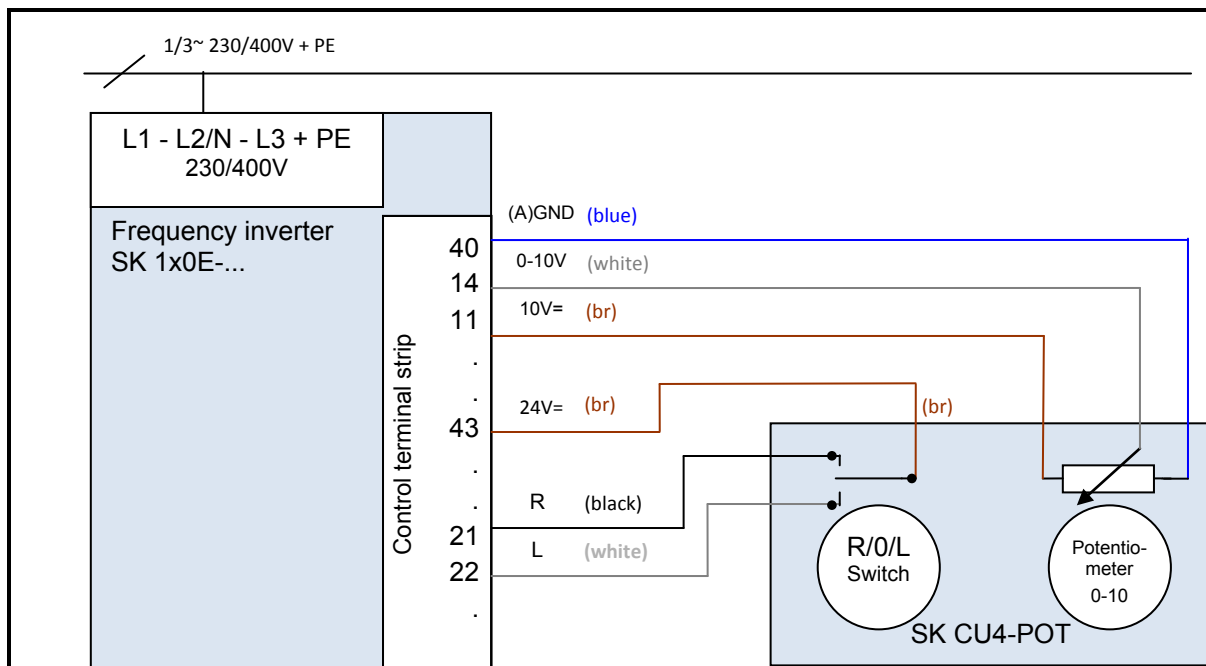

Figure 5: Connection diagram for SK CU4-POT, example of SK 1x0E

## 4 Commissioning

### WARNING

### Unexpected movement

Connection of the supply voltage may directly or indirectly set the drive unit into motion. This may cause an unexpected movement of the drive unit and the machine which is connected to it. This unexpected movement may cause severe or fatal injuries and/or material damage.

Unexpected movements may be due to several causes, e.g.

- Parameterisation of an "automatic start",
- Incorrect parameterisation,
- Control of the device with an enabling signal from a higher level control unit (via IO or bus signals),
- Incorrect motor data,
- Incorrect encoder connection,
- Release of a mechanical holding brake,
- External influences such as gravity or other kinetic energy which acts on the drive unit,
- In IT networks: Earth fault (short circuit to earth)

To avoid any resulting hazard the drive or drive chain must be secured against unexpected movements (mechanical blocking and/or decoupling, provision of protection against falling, etc.) In addition, it must be ensured that there are no persons within the area of action and the danger area of the system.

### 4.1 Factory settings

All frequency inverters supplied by Getriebebau NORD are pre-programmed with the default setting for standard applications with 4 pole standard motors (same voltage and power). For use with motors with other powers or number of poles, the data from the rating plate of the motor must be input into the parameters **P201...P207** under the menu item >Motor data<.

All motor data (IE1, IE4) can be pre-set using parameter **P200**. After use of this function, this parameter is reset to 0 = no change! The data is loaded automatically into parameters **P201...P209** – and can be compared again with the data on the motor rating plate.

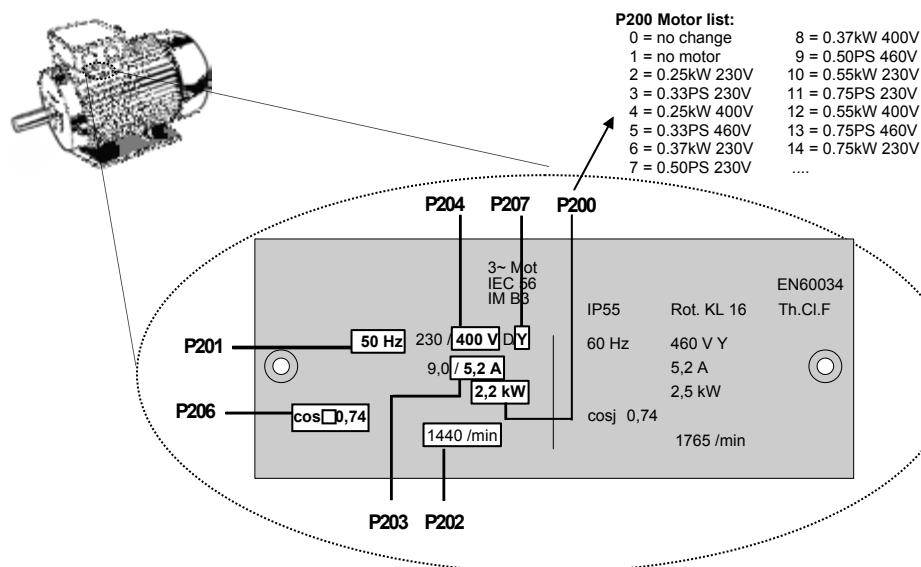

For the correct operation of the drive unit, it is necessary to input the motor data (rating plate) as precisely as possible. In particular, an automatic stator resistance measurement using parameter **P220** is recommended.



### 4.2 Starting up the device

The frequency inverter can be started up by making parameter adjustments using the ControlBox and the ParameterBox (SK CSX-3H or SK PAR-3H) or the NORD CON PC-based software. When doing this, the changes to the parameters are stored in the internal EEPROM.

#### **i** Information

#### Presetting of physical I/O and I/O bits

For commissioning standard applications, a limited number of the frequency inverter inputs and outputs (physical and I/O bits) have predefined functions. These settings may need to be changed (Parameters (P420), (P434), (P480), (P481)).

#### 4.2.1 Connection

In order to provide basic operational capability, after the device has been attached to the motor or the wall mounting kit, the power and motor lines must be connected to the relevant terminals ( Section 2.3.2 "Electrical connection of power unit").

#### 4.2.2 Configuration

Changes to individual parameters are usually necessary for operation.

##### 4.2.2.1 Parameterisation

The use of a ParameterBox (SK CSX-3H / SK PAR) or the NORDCON software is required in order to adapt the parameters.

Parameter group	Parameter numbers	Functions	Comments
Basic parameters	P102 ... P105	Ramp times and frequency limits	
Motor data	P201 ... P207, (P208)	Data on motor rating plate	
	P220, Function 1 alternatively P200	Measure stator resistance Motor data list	Value is written to P208 Selection of a 4-pole standard NORD motor from a list
	alternatively P220, Function 2	Motor identification	Complete measurement of a connected motor Prerequisite: Motor no more than 3 power levels less than the frequency inverter
Control terminals	P400, P420	Analogue and digital inputs	

#### **i** Information

#### Factory settings

Prior to restarting, it should be ensured that the frequency inverter is in its factory settings (P523).

The DIP switches S2 should remain in the "OFF" setting. The DIP switches S2 have priority over parameters P509, P514 and P515.

#### 4.2.2.2 DIP switches (S1, S2)

The analogue inputs in the device are suitable for current and voltage setpoints. For correct processing of current setpoints (0-20mA / 4-20mA) the relevant DIP switch (**S1** – bit 2 or 3) must be set to current signals ("ON").

DIP switch (**S1** – bit 1) sets the terminating resistance of the system bus.

The system settings can be made via DIP switch (**S2**). Settings made at DIP switch (S2) have priority over the parameters P509, P514 and P515.

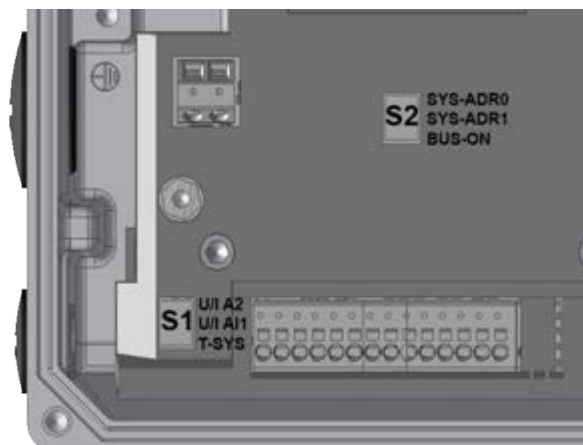

As delivered, all DIP switches are in the "0" ("OFF") position.

#### No.

##### Bit DIP switch (S1)

3	<b>U/I A2</b> <sup>1)</sup> Voltage / current	0	Analogue input 2 in voltage mode 0...10 V
		1	Analogue input 2 in current mode 0/4...20 mA
2	<b>U/I A1</b> <sup>1)</sup> Voltage / current	0	Analogue input 1 in voltage mode 0...10 V
		1	Analogue input 1 in current mode 0/4...20 mA
1	<b>T-SYS</b> Terminating resistance	0	System bus terminating resistance deactivated
		1	System bus terminating resistance activated

1) Adjustment to fail-safe signals in case of cable breaks (2-10 V / 4-20 mA) is made via parameters P402 and P403.

#### No.

##### Bit DIP switch (S2)

3/2	<b>SYS-ADR 0/1</b> System bus Address/ baud rate	<b>SYS-ADR</b>		
		1	0	
		0	0	In accordance with P515 and P514 [32, 250kBaud]
		0	1	Address 34, 250 kBaud
1	<b>BUS-ON</b> Control word and setpoint value source	1	0	Address 36, 250 kBaud
		1	1	Address 38, 250 kBaud
		0	In accordance with P509 and P510 [-01, -02]	
2 <sup>0</sup>		1	System bus (→ P509=3 and P510=3)	

### 4.2.3 Commissioning examples

All SK 1x0E models can be operated as delivered. Standard motor data for a 4-pole standard asynchronous motor of the same power is parameterised. The PTC input must be bypassed, if a motor with PTC is not available. Parameter (P428) must be changed if an automatic startup with "Mains On" is required.

#### Minimal configuration

The frequency inverter provides all the necessary control voltages (24 VDC / 10 VDC).

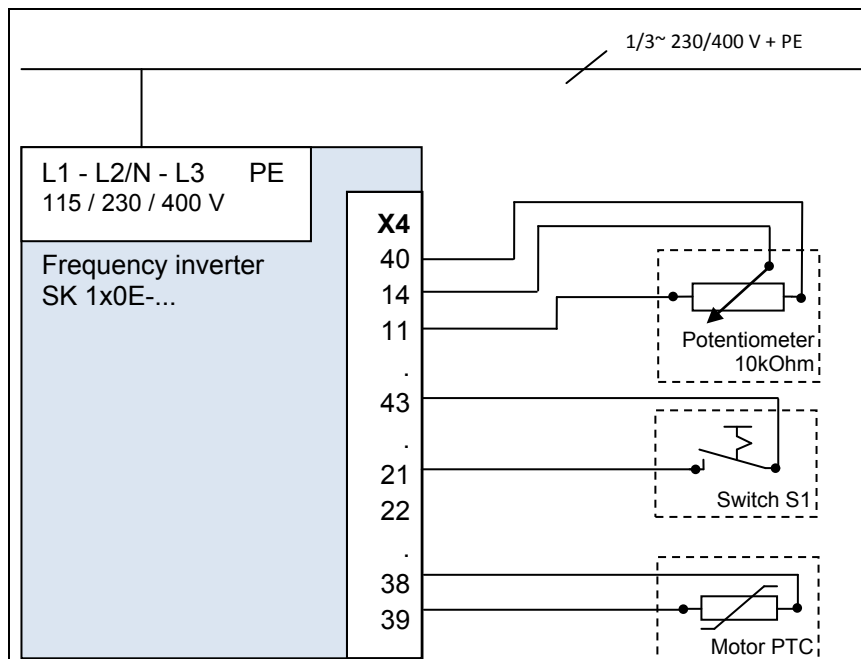

Function	Setting
Setpoint	External 10 kΩ potentiometer
Approval	External switch S1

#### Minimal configuration with options

In order to implement completely autonomous operation (independent of control cables etc.) a switch and a potentiometer such as potentiometer adapter SK CU4-POT is required. In this way, the speed and direction control in accordance with requirements can be achieved with only a single mains cable (single phase or three-phase depending on version) ( Section 3.1.2 "Potentiometer adapter, SK CU4-POT"),

## 5 Parameter



### WARNING

#### Unexpected movement

Connection of the supply voltage may directly or indirectly set the drive unit into motion. This may cause an unexpected movement of the drive unit and the machine which is connected to it. This unexpected movement may cause severe or fatal injuries and/or material damage.

Unexpected movements may be due to several causes, e.g.

- Parameterisation of an "automatic start",
- Incorrect parameterisation,
- Control of the device with an enabling signal from a higher level control unit (via IO or bus signals),
- Incorrect motor data,
- Incorrect encoder connection,
- Release of a mechanical holding brake,
- External influences such as gravity or other kinetic energy which acts on the drive unit,
- In IT networks: Earth fault (short circuit to earth)

To avoid any resulting hazard the drive or drive chain must be secured against unexpected movements (mechanical blocking and/or decoupling, provision of protection against falling, etc.) In addition, it must be ensured that there are no persons within the area of action and the danger area of the system.



### WARNING

#### Unexpected movement due to parameter changes

**Parameter changes become effective immediately.** Dangerous situations can occur under certain conditions, even when the drive is stationary. Functions such as **P428** "Automatic Start" or **P420** "Digital inputs" or the "Release Brake" setting can put the drive in motion and put persons at risk due to moving parts.

Therefore:

- Changes to parameter settings must only be made when the frequency inverter is not enabled.
- During parametrisation work precautions must be taken to prevent unwanted drive movements (e.g. lifting gear plunging down). The danger area of the system must not be entered.



### WARNING

#### Unexpected movement due to overload

In case of overload of the drive there is a risk that the motor will "break down" (= sudden loss of torque). An overload may be caused e.g. by underdimensioning of the drive unit or by the occurrence of sudden peak loads. Sudden peak loads may be of a mechanical origin (e.g. blockage) or may be due to extremely steep acceleration ramps (Parameter **P102**, **P103**, **P426**).

Depending on the type of application, "breakdown" of the motor may cause unexpected movement (e.g. dropping of loads by lifting gear).

To prevent any risk, the following must be observed:

- For lifting gear applications or applications with frequent, large load changes, the parameter (**P219**) must remain in the factory (**100 %**).
- Do not underdimension the drive unit, provide adequate overload reserves.
- If necessary, provide fall protection (e.g. for lifting gear) or equivalent protective measures.

The relevant parameters for the device are described in the following. The parameters are accessed using a parametrisation tool (e.g. NORDCON software or control and parametrisation unit, see also (📖 Section 3.1 "Control and parametrisation options ") and therefore makes it possible to adapt the device to the drive task in the best possible way. Different device configurations can result in dependencies for the relevant parameters.

The parameters can only be accessed if the control unit of the device is active.

For this purpose, the device is equipped with a power supply which generates the 24 V DC control voltage that is required by applying the mains voltage (see [☞](#) Section 2.3.2 "Electrical connection of power unit").

Limited adaptations of individual functions of the relevant devices can be implemented via DIP switches. Access to the parameters of the device is essential for all other adaptations. **It should be noted that the hardware configuration (DIP switches) has priority over configuration via software (parameterisation).**

Every frequency inverter is pre-configured for a NORD motor with the same power output in the factory. All parameters can be adjusted "online". Four switchable parameter sets are available during operation. The scope of the parameters to be displayed can be influenced using the Supervisor Parameter **P003**.

The relevant parameters for the device are described in the following. Explanation of parameters which relate to the field bus options or special functionality can be found in the respective supplementary manuals.

### Information

### SK PAR-3H ParameterBox

The SK PAR-3H ParameterBox must have at least software version **4.4 R2**.

The individual parameters are functionally combined into groups. The first digit of the parameter number indicates the assignment to a **menu group**:

Menu group	No.	Master function
<b>Operating displays</b>	(P0--)	Display of parameters and operational values
<b>Basic parameters</b>	(P1--)	Basic device settings, e.g. on/off switching behaviour.
<b>Motor data</b>	(P2--)	Electrical settings for the motor (motor current or start voltage (start-off voltage))
<b>PLC</b>	(P3--)	Settings for the integrated PLC
<b>Control terminals</b>	(P4--)	Assignment of functions for the inputs and outputs
<b>Extra parameters</b>	(P5--)	Priority monitoring functions and other parameters
<b>Information</b>	(P7--)	Display of operating values and status messages

### Information

### Factory settings P523

The factory setting of the entire parameter set can be loaded at any time using parameter **P523**. For example, this can be useful during commissioning if it is not known which device parameters were changed earlier and could therefore influence the operating behaviour of the drive in an undesirable way.

The restoration of the factory settings (**P523**) normally affects all parameters. This means that all motor data must subsequently be checked or reconfigured. However, parameter **P523** also provides a facility for excluding the motor data or the parameters relating to bus communication when the factory settings are restored.

To save the current device settings, these can be transferred to a ParameterBox memory beforehand (see [☞](#) [BU0040](#)).

## 5.1 Parameter overview

### Operating displays

<b>P000</b> Operating display	<b>P001</b> Selection of display value	<b>P002</b> Display factor
<b>P003</b> Display factor		

### Basic parameters

<b>P100</b> Parameter set	<b>P101</b> Copy parameter set	<b>P102</b> Acceleration time
<b>P103</b> Deceleration time	<b>P104</b> Minimum frequency	<b>P105</b> Maximum frequency
<b>P106</b> Ramp smoothing	<b>P107</b> Brake reaction time	<b>P108</b> Disconnection mode
<b>P109</b> DC brake current	<b>P110</b> Time DC-brake on	<b>P111</b> P factor torque limit
<b>P112</b> Torque current limit	<b>P113</b> Jog frequency	<b>P114</b> Brake delay off
<b>P120</b> Option monitoring		

### Motor data

<b>P200</b> Motor list	<b>P201</b> Nominal frequency of motor	<b>P202</b> Nominal speed
<b>P203</b> Nominal current	<b>P204</b> Nominal voltage of motor	<b>P205</b> Nominal power of motor
<b>P206</b> Cos phi	<b>P207</b> Motor circuit	<b>P208</b> Stator resistance
<b>P209</b> No load current	<b>P210</b> Static boost	<b>P211</b> Dynamic boost
<b>P212</b> Slip compensation	<b>P213</b> Amplification Isd control	<b>P214</b> Torque precontrol
<b>P215</b> Boost precontrol	<b>P216</b> Time boost prectrl.	<b>P217</b> Oscillation damping
<b>P218</b> Modulation depth	<b>P219</b> Auto. Magn. adaptation	<b>P220</b> Par.-identification
<b>P240</b> EMK voltage PMSM	<b>P241</b> Inductivity PMSM	<b>P243</b> Reluct. angle IPMSM
<b>P244</b> Peak current PMSM	<b>P245</b> Osc damping PMSM VFC	<b>P246</b> Mass Inertia PMSM
<b>P247</b> Switch freq VFC PMSM		

### Speed control

<b>P300</b> Servo mode		<b>P310</b> Speed controller P
<b>P311</b> Speed controller I	<b>P312</b> Torque current controller P	<b>P313</b> Torque current controller I
<b>P314</b> Torque current control limit	<b>P315</b> Field curr. ctrl. P	<b>P316</b> Field curr. ctrl. I
<b>P317</b> Field curr. ctrl. lim.	<b>P318</b> Field weakening controller P	<b>P319</b> Field weakening controller I
<b>P320</b> Weak border		
<b>P330</b> Rotor starting position detection	<b>P350</b> PLC functionality	<b>P351</b> PLC setpoint selection
<b>P353</b> Bus status via PLC	<b>P555</b> PLC integer setpoint	<b>P356</b> PLC long setpoint
<b>P360</b> PLC display value	<b>P370</b> PLC status	

**Control terminals**

<b>P400</b> Function Setpoint inputs	<b>P401</b> Analogue input mode	<b>P402</b> Adjustment: 0%
<b>P403</b> Adjustment: 100%	<b>P404</b> Analogue input filter	<b>P410</b> Min. freq. Auxiliary setpoint
<b>P411</b> Max. Freq. Auxiliary setpoint	<b>P412</b> Nom. val. process ctrl.	<b>P413</b> PI control P comp.
<b>P414</b> PI control I comp.	<b>P415</b> Limit process ctrl.	<b>P416</b> Ramp time PI setpoint
<b>P417</b> Offset analogue output	<b>P418</b> Funct. analogue output	<b>P419</b> Standard analogue output
<b>P420</b> Digital inputs	<b>P426</b> Quick stop time	<b>P427</b> Emerg. stop Fault
<b>P428</b> Automatic starting	<b>P434</b> Digital output function	<b>P435</b> Dig. out scaling
<b>P436</b> Dig. out. hysteresis	<b>P460</b> Watchdog time	<b>P464</b> Fixed frequency mode
<b>P465</b> Fixed freq. Array	<b>P466</b> Minimum freq. process control	<b>P475</b> delay on/off switch
<b>P480</b> Function BusIO In Bits	<b>P481</b> Function BusIO Out Bits	<b>P482</b> Standard BusIO Out Bits
<b>P483</b> Hyst. BusIO Out Bits		

**Extra parameters**

<b>P501</b> Inverter name	<b>P502</b> Master function value	<b>P503</b> Leading function output
<b>P504</b> Pulse frequency	<b>P505</b> Absolute minimum freq.	<b>P506</b> Auto. Fault acknowledgement
<b>P509</b> Control word source	<b>P510</b> Setpoint source	<b>P511</b> USS baud rate
<b>P512</b> USS address	<b>P513</b> Telegram timeout	<b>P514</b> CAN bus baud rate
<b>P515</b> CAN bus address	<b>P516</b> Skip frequency 1	<b>P517</b> Skip freq. area 1
<b>P518</b> Skip frequency 2	<b>P519</b> Skip freq. area 2	<b>P520</b> Flying start
<b>P521</b> Flying start Resolution	<b>P522</b> Flying start Offset	<b>P523</b> Factory setting
<b>P525</b> Load control max	<b>P526</b> Load control min	<b>P527</b> Load monitoring Freq.
<b>P528</b> Load monitoring delay	<b>P529</b> Mode Load control	<b>P533</b> Factor I <sup>2</sup> t
<b>P534</b> Torque shutoff lim.	<b>P535</b> I <sup>2</sup> t motor	<b>P536</b> Current limit
<b>P537</b> Pulse disconnection	<b>P539</b> Output monitoring	<b>P540</b> Mode phase sequence
<b>P541</b> Set relays	<b>P542</b> Set analogue out	<b>P543</b> Bus - Actual value
<b>P546</b> Function Setpoint Bus value	<b>P549</b> Pot Box function	
<b>P552</b> CAN master cycle	<b>P553</b> PLC setpoint	<b>P555</b> P - limit chopper
<b>P556</b> Braking resistor	<b>P557</b> Braking resistor type	<b>P558</b> Flux delay
<b>P559</b> DC Run-on time	<b>P560</b> Parameter, saving mode	

**Information**

<b>P700</b> Present Operating status	<b>P701</b> Last fault	<b>P702</b> Freq. last error
<b>P703</b> Current. last error	<b>P704</b> Volt. last error	<b>P705</b> Dc.lnk volt. last er.
<b>P706</b> P set last error	<b>P707</b> Software version	<b>P708</b> Status of digital in.
<b>P709</b> Analogue input voltage	<b>P710</b> Analogue output volt.	<b>P711</b> State of relays
<b>P714</b> Operating time	<b>P715</b> Running time	<b>P716</b> Current frequency
<b>P717</b> Current speed	<b>P718</b> Present Setpoint frequency	<b>P719</b> Actual current
<b>P720</b> Present Torque current	<b>P721</b> Actual field current	<b>P722</b> Current voltage
<b>P723</b> Voltage -d	<b>P724</b> Voltage -q	<b>P725</b> Current cos phi
<b>P726</b> Apparent power	<b>P727</b> Mechanical power	<b>P728</b> Input voltage
<b>P729</b> Torque	<b>P730</b> Field	<b>P731</b> Parameter set
<b>P732</b> Phase U current	<b>P733</b> Phase V current	<b>P734</b> Phase W current
<b>P735</b> Speed encoder	<b>P736</b> DC link current	<b>P737</b> Usage rate brake res.
<b>P738</b> Usage rate motor	<b>P739</b> Heatsink temperature	<b>P740</b> Process data Bus In
<b>P741</b> Process data Bus Out	<b>P742</b> Data base version	<b>P743</b> Inverter ID
<b>P744</b> Configuration		<b>P746</b> Option Status
<b>P747</b> Inverter Volt. Range		
<b>P748</b> CANopen status	<b>P749</b> Status of DIP switches	<b>P750</b> Stat. Overcurrent
<b>P751</b> Stat. Overvoltage	<b>P752</b> Stat. Mains fault	<b>P753</b> Stat. Overtemp.
<b>P754</b> Stat. Param. loss	<b>P755</b> Stat. System error	<b>P756</b> Stat. Timeout
<b>P757</b> Stat. Customer error	<b>P760</b> Current mains current	<b>P799</b> Op.-time last error

**Parameter list - inverter functions (selection)**

Parameter	Description	Factory setting	Settings / functions (selection)
P102 Acceleration time	Start-up time (acceleration ramp) is the time corresponding to the linear frequency rise from 0Hz to the set maximum frequency (P105).	[2.00]	Note: Values < 0.1 must be avoided
P103 Deceleration time	The braking time (braking ramp) is the time corresponding to the linear frequency reduction from the set maximum frequency (P105) to 0Hz.	[2.00]	Note: Values < 0.1 must be avoided
P104 Minimum frequency	The minimum frequency is the frequency supplied by the FI as soon as it is enabled and no additional setpoint is set.	[0]	
P105 Maximum frequency	Is the frequency provided by the FI after it has been enabled and the maximum setpoint value is available.	[50]	
P200 Motor list	If a 4-pole NORD motor is used, the preset motor data can be called up.	[0]	Select appropriate motor power
P201 – P208 Motor data	If a 4-pole NORD motor is not used, the motor data on the rating plate must be entered here.	[xxx]	Data according to rating plate
P220 Parameter identification	The motor data is automatically determined by the FI with this parameter.	[0]	01= stator resistor only 02 = motor identification
P400 Function, setpoint inputs	Definition of the functions of the various setpoint inputs <i>Input selection:</i> AIN1 (P400, [-01]) AIN2 (P400, [-02])	[xxx]	00 = No function 01= setpoint frequency
P420 Digital input functions	Definition of the functions of the various digital inputs <i>Input selection:</i> DIN 1 (P420, [-01]) DIN 2 (P420, [-02]) DIN 3 (P420, [-03])	[xxx]	00= No function 01= Enable right 02= Enable left 04= Fixed frequency 1 05= Fixed frequency 2
P428 Automatic starting	Inverter enable with "Mains On"	[0]	0= Off (enable with edge) 1= On (enable with level) <b>Note:</b> a digital input must be programmed for enable and set!
P465 Fixed frequency /Fixed frequency array	Definition of fixed frequency values <i>Selection:</i> Fixed frequency 1 (P465, [-01]) Fixed frequency 2 (P465, [-02])	[xxx]	
P509 Control word source	Selection of the interface via which the FI is controlled.	[0]	00= Control terminals or keyboard 01= Only control terminals 03= System bus
P523 Factory setting	Frequency inverter is restored to the factory setting	[0]	00= No change 01= Load factory setting



**Parameter list - inverter information (selection)**

Parameter	Description	Settings / functions (selection)
P700 Present operating status	Display of current messages for the actual operating status of the frequency inverter such as faults, warnings or the cause of a switch-on block. <i>Selection:</i> Actual fault (P700, [-01]) Actual warning (P700, [-02]) Reason for switch-on block (P700, [-03])	Error group: 1 / 2 = Overtemperature of inverter / motor 3 / 4 = Overcurrent error 5 = Overvoltage error 16 = Motor phase monitoring 19...= Parameter identification error
P701 Last error	Displays the last 5 frequency inverter faults. <i>Selection:</i> Last fault (P701, [-01]) Second to last fault (P701, [-02])	See P700
P707 Software version	Displays the firmware version / Inverter revision <i>Selection:</i> Software version (P707, [-01]) Revision (P707, [-02])	
P708 Status of digital input	Shows the switching status of the digital inputs.	Bit 0 = DIN 1 Bit 1 = DIN 2 ...
P709 Voltage of analogue input	Displays the measured analogue input value. <i>Input selection:</i> AIN1 (P400, [-01]) AIN2 (P400, [-02])	
P719 Actual current	Displays the actual output current.	
P740 Process data Bus In	Displays the actual control word and the setpoints.	[-01] = STW (Source P509) [-02...-04] SW 1...3 (Source P510[-01]) [-11...-13] SW 1...3 (Source P510[-02])
P749 State of DIP switch	Displays the actual DIP switch setting (S1).	Bit 0 = DIP switch 1 Bit 1 = DIP switch 2 ...

## 6 Operating status messages

The device and technology units generate appropriate messages if they deviate from their normal operating status. There is a differentiation between warning and error messages. If the device is in the status "Start disabled", the reason for this can also be displayed.

The messages generated for the device are displayed in the corresponding array of parameter (**P700**). The display of the messages for technology units is described in the respective additional instructions and data sheets for the modules concerned.

### Start disabled, "Not Ready" → (P700 [-03])

If the device is in the status "Not Ready" or "Start Disabled", the reason for this is indicated in the third array element of parameter (**P700**).

Display is only possible with the NORD CON software or the ParameterBox.

### Warning messages → (P700 [-02])

Warning messages are generated as soon as a defined limit is reached. However this does not cause the frequency inverter to switch off. These messages can be displayed via the array-element [-02] in parameter (**P700**) until either the reason for the warning is no longer present or the frequency inverter has gone into a fault state with an error message.

### Error messages → (P700 [-01])

Errors cause the device to switch off, in order to prevent a device fault.

The following options are available to reset a fault (acknowledge):

- Switching the mains off and on again,
- By an appropriately programmed digital input (**P420**),
- By switching off the "enable" on the device (if no digital input is programmed for acknowledgement),
- By Bus acknowledgement
- By (**P506**), automatic error acknowledgement.

### 6.1 Display of messages

#### LED displays

The status of the FI is indicated by integrated status LEDs, which are visible from the outside in the state as delivered. According to the type of FI, this is a two-colour LED (DS = DeviceState) or two single-colour LEDs (DS DeviceState and DE = DeviceError).

<b>Meaning:</b>	<p><b>Green</b> indicates readiness and the present of mains voltage. In operation, the level of overload at the FI output is shown with an increasingly rapid flashing code.</p> <p><b>Red</b> Signals the presence of an error by flashing according to the number code of the error. This flashing code (e.g.: E003 = 3x flashing) indicates the error groups.</p>
-----------------	---

### SimpleBox - display

The SimpleBox displays an error with its number and the prefix "E". In addition, the current fault can be displayed in array element [-01] of parameter (P700). The last error messages are stored in parameter P701. Further information on inverter status at the time that the error occurs can be found in parameters P702 to P706 / P799.

If the cause of the error is no longer present, the error display in the SimpleBox flashes and the error can be acknowledged with the Enter key.

In contrast, warning messages are prefixed with "C" ("Cxxx") and cannot be acknowledged. They disappear automatically when the reason for them is no longer present or the frequency inverter has switched to the "Error" state. Display of the message is suppressed if the warning appears during parameterisation.

The present warning message can be displayed in detail at any time in array element [-02] of parameter (P700).

The reason for an existing disabled switch on cannot be displayed with the SimpleBox.

### ParameterBox display

The ParameterBox displays the messages in plain text.

## 6.2 Diagnostic LEDs on device

The device generates operating status messages. These messages (warnings, errors, switching statuses, measurement data) can be displayed with parametrisation tools (📖 Section 3.1 "Control and parametrisation options ") (Parameter group **P7xx**).

To a limited extent, the messages are also indicated via the diagnostic and status LEDs.

### Diagnostic LEDs

LED			Status signal <sup>1)</sup>		Meaning
Name	Colour	Description			
DS	red/green	Device status	Off		Device not ready for operation • No control voltage
			green on		Device ready for operation
			green flashing	0.5 Hz	Device ready for switching on
				4 Hz	Device in switch-on block
			red/green Alternating	4 Hz	Warning
			green on + red flashing	1..25 Hz	Degree of overload of switched-on device
					Device not ready for operation
red flashing		Error, flashing frequency represents error number			
ASi	red/green	Status of AS-i			Details (📖 <a href="#">BU0180</a> )

1) Signal status = specification of LED colour + flashing frequency (switch-on frequency per second), example "red flashes, 2 Hz" = red LED switches on and off 2x per second

## 6.3 Messages

### Error messages

Display in the SimpleBox / ControlBox		Fault Text in the ParameterBox	Cause • Remedy
Group	Details in P700 [-01] / P701		
E001	1.0	<b>Overtemp. Inverter</b> <i>"Inverter overtemperature"</i> (inverter heat sink)	Inverter temperature monitoring measurements are outside of the permissible temperature range, i.e. the error is triggered if the permissible lower limit is undershot or the permissible upper temperature limit is exceeded.
	1.1	<b>Overtemp. FI internal</b> <i>"Internal FI overtemperature"</i> (interior of FI)	<ul style="list-style-type: none"> <li>• Depending on the cause: Reduce or increase the ambient temperature</li> <li>• Check the FI fan / control cabinet ventilation</li> <li>• Check the FI for dirt</li> </ul>
E002	2.0	<b>Overtemp. Motor PTC</b> <i>"Overtemperature motor thermistor "</i>	Motor temperature sensor (PTC) has triggered <ul style="list-style-type: none"> <li>• Reduce motor load</li> <li>• Increase motor speed</li> <li>• Use external motor fan</li> </ul>
	2.1	<b>Overtemp. Motor I<sup>2</sup>t</b> <i>"Motor overtemperature I<sup>2</sup>t"</i>  Only if I <sup>2</sup> t motor (P535) is programmed.	I <sup>2</sup> t motor has triggered (calculated overtemperature of motor) <ul style="list-style-type: none"> <li>• Reduce motor load</li> <li>• Increase motor speed</li> </ul>
	2.2	<b>Overtemp. Brake r.ext</b> <i>"Overtemperature of external brake resistor "</i>  Overtemperature via digital input (P420 [...])={13}	Temperature monitor (e.g. brake resistor) has activated <ul style="list-style-type: none"> <li>• Digital input is Low</li> <li>• Check connection, temperature sensor</li> </ul>
E003	3.0	<b>I<sup>2</sup>t overcurrent limit</b>	a.c. inverter: I <sup>2</sup> t limit has triggered, e.g. > 1.5 x I <sub>n</sub> for 60s (also note P504) <ul style="list-style-type: none"> <li>• Continuous overload at inverter output</li> <li>• Possible encoder fault (resolution, defect, connection)</li> </ul>
	3.1	<b>Chopper overtemperature I<sup>2</sup>t</b>	Brake chopper: I <sup>2</sup> t limit has activated, 1.5 times values reached for 60s (please also pay attention to P554, if present, and P555, P556, P557) <ul style="list-style-type: none"> <li>• Avoid overcurrent in brake resistance</li> </ul>
	3.2	<b>IGBT overcurrent</b> 125% monitoring	De-rating (power reduction) <ul style="list-style-type: none"> <li>• 125% overcurrent for 50ms</li> <li>• Brake chopper current too high</li> <li>• for fan drives: enable flying start circuit (P520)</li> </ul>
	3.3	<b>IGBT overcurrent fast</b> 150% monitoring	De-rating (power reduction) <ul style="list-style-type: none"> <li>• 150% overcurrent</li> <li>• Brake chopper current too high</li> </ul>

## 6 Operating status messages

E004	4.0	<b>Overcurrent module</b>	<p>Error signal from module (short duration)</p> <ul style="list-style-type: none"> <li>• Short-circuit or earthing fault at FI output</li> <li>• Motor cable is too long</li> <li>• Use external output choke</li> <li>• Brake resistor faulty or resistance too low</li> </ul> <p><b>→ Do not shut off P537!</b></p> <p><b>The occurrence of a fault can significantly shorten the service life of the device, or even destroy it.</b></p>
	4.1	<b>Overcurrent measurement</b> <i>"Overcurrent measurement"</i>	<p>P537 (pulse current switch-off) was reached 3x within 50 ms (only possible if P112 and P536 are disabled)</p> <ul style="list-style-type: none"> <li>• FI is overloaded</li> <li>• Drive sluggish, insufficiently sized</li> <li>• Ramps (P102/P103) too steep -&gt; Increase ramp time</li> <li>• Check motor data (P201 ... P209)</li> </ul>
E005	5.0	<b>Overvoltage UZW</b>	<p>Link circuit voltage too high</p> <ul style="list-style-type: none"> <li>• Increase deceleration time (P103)</li> <li>• If necessary, set switch-off mode (P108) with delay (not with lifting equipment)</li> <li>• Extend emergency stop time (P426)</li> <li>• Fluctuating speed (e.g. due to high centrifugal masses) → adjust U/f characteristic curve if necessary (P211, P212)</li> </ul> <p>Devices with brake chopper:</p> <ul style="list-style-type: none"> <li>• Reduce energy return using a braking resistor</li> <li>• Check the function of the connected braking resistor (broken cable)</li> <li>• Resistance value of connected braking resistor too high</li> </ul>
	5.1	<b>Mains overvoltage</b>	<p>Mains voltage is too high</p> <ul style="list-style-type: none"> <li>• See technical data (📖 Section 7)</li> </ul>
E006	---	<b>Reserved</b>	
E008	8.0	<b>Parameter loss</b> (maximum EEPROM value exceeded)	<p>Error in EEPROM data</p> <ul style="list-style-type: none"> <li>• Software version of the stored data set not compatible with the software version of the FI.</li> </ul> <p><b>NOTE:</b> <u>Faulty parameters</u> are automatically reloaded (default data).</p> <ul style="list-style-type: none"> <li>• EMC interferences (see also E020)</li> </ul>
	8.1	<b>Inverter type incorrect</b>	<ul style="list-style-type: none"> <li>• EEPROM faulty</li> </ul>
	8.2	<b>Reserved</b>	
	8.3	<b>EEPROM KSE error</b> (Customer unit incorrectly identified (customer's interface equipment))	<p>The upgrade level of the frequency inverter was not correctly identified.</p> <ul style="list-style-type: none"> <li>• Switch mains voltage off and on again.</li> </ul>
	8.4	<b>Internal EEPROM error</b> (Database version incorrect)	
	8.7	<b>EEPR copy not the same</b>	
E009	---	<b>Reserved</b>	

E010	10.0	<b>Bus Timeout</b>	Telegram time-out / Bus off 24V int. CANbus <ul style="list-style-type: none"> <li>• Data transfer is faulty. Check P513.</li> <li>• Check physical bus connections</li> <li>• Check bus protocol program process.</li> <li>• Check Bus Master.</li> <li>• Check 24V supply of internal CAN/CANopen Bus.</li> <li>• Node guarding error (internal CANopen)</li> <li>• <i>Bus Off</i> error (internal CANbus)</li> </ul>
	10.2	<b>Bus Timeout Option</b>	Telegram timeout <ul style="list-style-type: none"> <li>• Telegram transfer is faulty.</li> <li>• Check physical bus connections</li> <li>• Check bus protocol program process.</li> <li>• Check Bus Master.</li> <li>• PLC is in the "STOP" or "ERROR" state.</li> </ul>
	10.4	<b>Init error Option</b>	Initialisation error in bus module <ul style="list-style-type: none"> <li>• Check Bus module current supply.</li> <li>• DIP switch setting of a connected I/O extension module is incorrect</li> </ul>
	10.1	<b>System error option</b>	System error bus module <ul style="list-style-type: none"> <li>• Further details can be found in the respective additional bus instructions.</li> </ul>
	10.3		
	10.5		
10.6			
10.7			
10.9	<b>Module missing / P120</b>	The module entered in parameter (P120) is not available. <ul style="list-style-type: none"> <li>• Check connections</li> </ul>	
E011	11.0	<b>Customer interface</b>	Error in analog-digital converter <ul style="list-style-type: none"> <li>• Internal customer unit (internal data bus) faulty or damaged by radio radiation (EMC)</li> <li>• Check control connections for short-circuit.</li> <li>• Minimize EMC interference by laying control and power cables separately.</li> <li>• Earth the devices and shields well.</li> </ul>
E012	12.0	<b>External watchdog</b>	The Watchdog function is selected at a digital input and the impulse at the corresponding digital input is not present for longer than the time set in parameter P460 >Watchdog time<. <ul style="list-style-type: none"> <li>• Check connections</li> <li>• Check setting P460</li> </ul>
	12.1	<b>Limit moto./Customer</b> <i>"Drive switch-off limit"</i>	The drive switch-off limit (P534 [-01]) has triggered. <ul style="list-style-type: none"> <li>• Reduce load on motor</li> <li>• Set higher value in (P534 [-01]).</li> </ul>
	12.2	<b>Limit gen.</b> <i>"Generator switch-off limit"</i>	The generator switch-off limit (P534 [-02]) has triggered. <ul style="list-style-type: none"> <li>• Reduce load on motor</li> <li>• Set higher value in (P534 [-02]).</li> </ul>
	12.3	<b>Torque limit</b>	Limit from potentiometer or setpoint source has switched off. P400 = 12
	12.4	<b>Current limit</b>	Limit from potentiometer or setpoint source has switched off. P400 = 14

## 6 Operating status messages

	<b>12.5</b>	<b>Load monitor</b>	Switch-off due to overshooting or undershooting of permissible load torques ((P525) ... (P529)) for the time set in (P528). <ul style="list-style-type: none"> <li>• Adjust load.</li> <li>• Change limit values ((P525) ... (P527)).</li> <li>• Increase delay time (P528).</li> <li>• Change monitoring mode (P529).</li> </ul>
	<b>12.8</b>	<b>AI minimum</b> <i>„Analogue In minimum“</i>	Switch-off due to undershooting of the 0% adjustment value (P402) with setting (P401) "0-10V with switch-off on error 1" or "...2"
	<b>12.9</b>	<b>AI maximum</b> <i>„Analogue In maximum“</i>	Switch-off due to overshooting of the 100% adjustment value (P402) with setting (P401) "0-10V with switch-off on error 1" or "...2"
E013	<b>13.2</b>	<b>Shut-down monitoring</b>	The slip error monitoring was triggered; the motor could not follow the setpoint. <ul style="list-style-type: none"> <li>• Check motor data P201-P209! (important for current controllers)</li> <li>• Check motor circuit</li> <li>• Check encoder settings P300 and following in servo mode</li> <li>• Increase setting value for torque limit in P112</li> <li>• Increase setting value for current limit in P536</li> <li>• Check deceleration time P103 and extend if necessary</li> </ul>
E015	---	<b>Reserved</b>	
E016	<b>16.0</b>	<b>Motor phase error</b>	A motor phase is not connected. <ul style="list-style-type: none"> <li>• Check P539</li> <li>• Check motor connection</li> </ul>
	<b>16.1</b>	<b>Magnetisation current monitoring</b> <i>"Magnetisation current monitoring"</i>	Required exciting current not achieved at moment of switch-on. <ul style="list-style-type: none"> <li>• Check P539</li> <li>• Check motor connection</li> </ul>
E019	<b>19.0</b>	<b>Parameter identification</b> <i>"Parameter identification"</i>	Automatic identification of the connected motor was unsuccessful <ul style="list-style-type: none"> <li>• Check motor connection</li> <li>• Check preset motor data (P201 ... P209)</li> <li>• PMSM – CFC Closed Loop Operation: Rotor position of motor incorrect in relation to incremental encoder Perform determination of rotor position (initial enable after a "Mains on" only with motor stationary (P330)</li> </ul>
	<b>19.1</b>	<b>Star / Delta circuit incorrect</b> <i>"Motor star / delta circuit incorrect"</i>	
E020	<b>20.0</b>	<b>Reserved</b>	
E021	<b>20.1</b>	<b>Watchdog</b>	
	<b>20.2</b>	<b>Stack overflow</b>	System error in program execution, triggered by EMC interference. <ul style="list-style-type: none"> <li>• Observe wiring guidelines</li> <li>• Use additional external mains filter.</li> <li>• FI must be very well earthed.</li> </ul>
	<b>20.3</b>	<b>Stack underflow</b>	
	<b>20.4</b>	<b>Undefined opcode</b>	
	<b>20.5</b>	<b>Protected Instruct.</b> <i>"Protected Instruction"</i>	
	<b>20.6</b>	<b>Illegal word access</b>	

20.7	<b>Illegal Inst. Access</b> <i>"Illegal instruction access"</i>	
20.8	<b>Program memory error</b> <i>"Program memory error"</i> (EEPROM error)	
20.9	<b>Dual-ported RAM</b>	
21.0	<b>NMI error</b> (Not used by hardware)	
21.1	<b>PLL error</b>	
21.2	<b>ADU error "Overrun"</b>	
21.3	<b>PMI error "Access Error"</b>	
21.4	<b>Userstack overflow</b>	
E022	---	<b>Reserved</b> Error message for PLC → see supplementary instructions <a href="#">BU 0550</a>
E023	---	<b>Reserved</b> Error message for PLC → see supplementary instructions <a href="#">BU 0550</a>
E024	---	<b>Reserved</b> Error message for PLC → see supplementary instructions <a href="#">BU 0550</a>

### Warning messages

Display in the SimpleBox / ControlBox		Warning Text in the ParameterBox	Cause • Remedy
Group	Details in P700 [-02]		
C001	1.0	<b>Overtemp. Inverter</b> <i>"Inverter overtemperature"</i> (inverter heat sink)	Inverter temperature monitoring Warning: permissible temperature limit reached. <ul style="list-style-type: none"> <li>• Reduce ambient temperature</li> <li>• Check the FI fan / control cabinet ventilation</li> <li>• Check the FI for dirt</li> </ul>
C002	2.0	<b>Overtemp. Motor PTC</b> <i>"Overtemperature motor thermistor "</i>	Warning from motor temperature sensor (triggering threshold reached) <ul style="list-style-type: none"> <li>• Reduce motor load</li> <li>• Increase motor speed</li> <li>• Use external motor fan</li> </ul>
	2.1	<b>Overtemp. Motor I<sup>2</sup>t</b> <i>"Motor overtemperature I<sup>2</sup>t"</i>  <u>Only</u> if I <sup>2</sup> t motor (P535) is programmed.	Warning: I <sup>2</sup> t- motor monitoring (1.3 times the rated current reached for the time period specified in (P535)) <ul style="list-style-type: none"> <li>• Reduce motor load</li> <li>• Increase motor speed</li> </ul>
	2.2	<b>Overtemp. Brake r.ext</b> <i>"Overtemperature of external brake resistor "</i>  Overtemperature via digital input (P420 [...])={13}	Warning: Temperature monitor (e.g. brake resistor) has activated <ul style="list-style-type: none"> <li>• Digital input is Low</li> </ul>



## 6 Operating status messages

C003	3.0	<b>Overcurrent, I<sup>2</sup>t limit</b>	Warning: Inverter: I <sup>2</sup> t limit has triggered, e.g. > 1.3 x I <sub>n</sub> for 60s (please also note P504) <ul style="list-style-type: none"> <li>• Continuous overload at FI output</li> </ul>
	3.1	<b>Overcurrent, chopper I<sup>2</sup>t</b>	Warning: I <sup>2</sup> t limit for the brake chopper has triggered, 1.3x value attained for 60s (also note P554, if present, as well as P555, P556, P557) <ul style="list-style-type: none"> <li>• Avoid overload of brake resistance</li> </ul>
	3.5	<b>Torque current limit</b>	Warning: Torque current limit reached <ul style="list-style-type: none"> <li>• Check (P112)</li> </ul>
	3.6	<b>Current limit</b>	Warning: Current limit reached <ul style="list-style-type: none"> <li>• Check (P536)</li> </ul>
C004	4.1	<b>Overcurrent measurement</b> "Overcurrent measurement"	Warning: pulse switch off is active The limit for activation of pulse switch off (P537) has been reached (only possible if P112 and P536 are switched off) <ul style="list-style-type: none"> <li>• FI is overloaded</li> <li>• Drive sluggish, insufficiently sized</li> <li>• Ramps (P102/P103) too steep -&gt; Increase ramp time</li> <li>• Check motor data (P201 ... P209)</li> <li>• Switch off slip compensation (P212)</li> </ul>
C008	8.0	<b>Parameter loss</b>	Warning: One of the cyclically saved messages such as <i>operating hours</i> or <i>enabling time</i> could not be saved successfully.  The warning disappears as soon as saving can be successfully performed.
C012	12.1	<b>Limit moto./Customer</b> "Drive switch-off limit"	Warning: 80 % of the drive switch-off limit (P534 [-01]) has been exceeded. <ul style="list-style-type: none"> <li>• Reduce load on motor</li> <li>• Set higher value in (P534 [-01]).</li> </ul>
	12.2	<b>Limit gen.</b> "Generator switch-off limit"	Warning: 80 % of the generator switch-off limit (P534 [-02]) has been reached. <ul style="list-style-type: none"> <li>• Reduce load on motor</li> <li>• Set higher value in (P534 [-02]).</li> </ul>
	12.3	<b>Torque limit</b>	Warning: 80 % of the limit from the potentiometer or the setpoint source has been reached. P400 = 12
	12.4	<b>Current limit</b>	Warning: 80 % of the limit from the potentiometer or the setpoint source has been reached. P400 = 14
	12.5	<b>Load monitor</b>	Warning due to overshooting or undershooting of permissible load torques ((P525) ... (P529)) for the time set in (P528). <ul style="list-style-type: none"> <li>• Adjust load.</li> <li>• Change limit values ((P525) ... (P527)).</li> <li>• Increase delay time (P528).</li> </ul>

### Switch-on block messages

Display in the SimpleBox / ControlBox		Reason: Text in the ParameterBox	Cause • Remedy
Group	Details in P700 [-03]		
I000	0.1	<b>Disable voltage from IO</b>	If the function "disable voltage" is parameterised, input (P420 / P480) is at Low <ul style="list-style-type: none"> <li>• Set "input High"</li> <li>• Check signal cable (broken cable)</li> </ul>
	0.2	<b>IO fast stop</b>	If the function "fast stop" is parameterised, input (P420 / P480) is at Low <ul style="list-style-type: none"> <li>• Set "input High"</li> <li>• Check signal cable (broken cable)</li> </ul>
	0.3	<b>Block voltage from bus</b>	<ul style="list-style-type: none"> <li>• For bus operation (P509): control word Bit 1 is "Low"</li> </ul>
	0.4	<b>Bus fast stop</b>	<ul style="list-style-type: none"> <li>• For bus operation (P509): control word Bit 2 is "Low"</li> </ul>
	0.5	<b>Enable on start</b>	Enable signal (control word, Dig I/O or Bus I/O) was already applied during the initialisation phase (after mains "ON", or control voltage "ON"). Or electrical phase is missing. <ul style="list-style-type: none"> <li>• Only issue enable signal after completion of initialisation (i.e. when the FI is ready)</li> <li>• Activation of "Automatic Start" (P428)</li> </ul>
	0.6 – 0.7	<b>Reserved</b>	Information message for PLC → see supplementary instructions
	0.8	<b>Right direction blocked</b>	Switch-on block with inverter shut-off activated by: <b>P540</b> or by "Enable right block" ( <b>P420</b> = 31, 73) or "Enable left block" ( <b>P420</b> = 32, 74), The frequency inverter switches to "Ready for switching on" status
	0.9	<b>Left direction blocked</b>	
I006 <sup>1)</sup>	<b>6.0</b>	<b>Charging error</b>	Charging relay not energised, because: <ul style="list-style-type: none"> <li>• Mains / link voltage too low</li> <li>• Mains failure</li> <li>• Evacuation run activated ((P420) / (P480))</li> </ul>
I011	<b>11.0</b>	<b>Analog Stop</b>	If an analog input of the frequency inverter or a connected IO extension is configured to detect cable breaks (2-10V signal or 4-20mA signal), the frequency inverter switches to the status "ready for switch-on" if the analog signal undershoots the value <b>1 V</b> or <b>2 mA</b> This also occurs if the relevant analog input is parameterised to function "0" ("no function"). <ul style="list-style-type: none"> <li>• Check connections</li> </ul>

1) Indication of operating mode (message) on the *ParameterBox* or virtual operating unit of the *NORD CON-Software*: "**Not ready**"

### 6.4 FAQ operational problems

Fault	Possible cause	Remedy
Device will not start (all LEDs off)	<ul style="list-style-type: none"> <li>No mains voltage or wrong mains voltage</li> </ul>	<ul style="list-style-type: none"> <li>Check connections and supply cables</li> <li>Check switches / fuses</li> </ul>
Device does not react to enabling	<ul style="list-style-type: none"> <li>Control elements not connected</li> <li>Incorrect control word source setting</li> <li>Right and left enable signals present simultaneously</li> <li>Enable signal present before device ready for operation (device expecting a 0 → 1 edge)</li> </ul>	<ul style="list-style-type: none"> <li>Reset enable</li> <li>Change over <b>P428</b> if necessary: "0" = device expecting a 0→1 edge for enable / "1" = device reacts to "Level" → <b>Danger: Drive can start up independently!</b></li> <li>Check control connections</li> <li>Check <b>P509</b></li> </ul>
Motor will not start in spite of enable being present	<ul style="list-style-type: none"> <li>Motor cables not connected</li> <li>Brake not ventilating</li> <li>No setpoint specified</li> <li>Incorrect setpoint source setting</li> </ul>	<ul style="list-style-type: none"> <li>Check connections and supply cables</li> <li>Check control elements</li> <li>Check <b>P510</b></li> </ul>
Device switches off without error message when load increases (increased mechanical load / speed)	<ul style="list-style-type: none"> <li>Mains phase missing</li> </ul>	<ul style="list-style-type: none"> <li>Check connections and supply cables</li> <li>Check switches / fuses</li> </ul>
Motor rotating in wrong direction	<ul style="list-style-type: none"> <li>Motor cable U-V-W interchanged</li> </ul>	<ul style="list-style-type: none"> <li>Motor cable Switch 2 phases</li> <li>Alternatively: <ul style="list-style-type: none"> <li>– Switch parameter <b>P420</b> right / left enable functions</li> <li>– Switch control word bits 11/12 (with bus actuation)</li> </ul> </li> </ul>
Motor not reaching required speed	<ul style="list-style-type: none"> <li>Maximum frequency parameter setting too low</li> </ul>	<ul style="list-style-type: none"> <li>Check <b>P105</b></li> </ul>

<p>Motor speed does not correspond to setpoint</p>	<ul style="list-style-type: none"> <li>• Analogue input function set to "Frequency addition" and another setpoint is present</li> </ul>	<ul style="list-style-type: none"> <li>• Check <b>P400</b></li> <li>• <b>P420</b>, check active fixed frequencies</li> <li>• Check bus setpoints</li> <li>• Check <b>P104 / P105</b> "min. / max. frequency"</li> <li>• <b>P113</b> Check "jog frequency"</li> </ul>
<p>Intermittent communication error between FI and option modules</p>	<ul style="list-style-type: none"> <li>• System bus terminating resistor not set</li> <li>• Poor connection contacting</li> <li>• Interference on system bus line</li> <li>• Maximum system bus length exceeded</li> </ul>	<ul style="list-style-type: none"> <li>• First and last subscriber only: Set DIP switches for terminating resistance</li> <li>• Check connections</li> <li>• Connect GND of all FI connected to system bus</li> <li>• Pay attention to routing regulations (separate routing of signal and control cables and mains and motor cables)</li> <li>• Check cable lengths (system bus)</li> </ul>

**Table 6: FAQ operational problems**

## 7 Technical data

### 7.1 General data for frequency inverter

Function	Specification
Output frequency	0.0 ... 400.0 Hz
Pulse frequency	3.0 ... 16.0 kHz, factory setting = 6 kHz Power reduction > 8 kHz with 115 / 230 V device, > 6 kHz with 400 V device
Typical overload capacity	150 % for 60 s, 200 % for 3.5 s
Efficiency	> 95 % according to size
Insulation resistance	> 10 MΩ
Operating / ambient temperature	-25°C ... +40°C, for details (including UL values) for individual devices and operating modes, see (📖 <a href="#">BU0180</a> ) ATEX: -20...+40°C (chapter 2.4)
Storage and transport temperature	-25°C ... +60/70°C
Long-term storage	(chapter 9)
Protection class	IP55, optional IP66 (chapter 1.6)
Max. installation altitude above sea level	<i>Up to 1000 m</i> No power reduction  <i>1000...2000 m:</i> 1 %/ 100 m power reduction, overvoltage category 3  <i>2000...4000 m:</i> 1 % / 100 m power reduction, overvoltage category 2, external overvoltage protection required at mains input
Ambient conditions	<i>Transport (IEC 60721-3-2):</i> Mechanical: 2M2 <i>Operation (IEC 60721-3-3):</i> Mechanical: 3M7 Climatic: 3K3 (IP55) 3K4 (IP66)
Environmental protection	<i>Energy-saving function</i> (📖 <a href="#">BU0180</a> ), see P219 <i>EMC</i> (📖 <a href="#">BU0180</a> ) <i>RoHS</i> (chapter 1.4)
Protective measures against	Overtemperature of the frequency inverter Short-circuit, earth fault Over and under-voltage Overload, idle running
Motor temperature monitoring	I <sup>2</sup> t motor, PTC / bimetallic switch
Regulation and control	Sensorless current vector control (ISD), linear V/f characteristic curve, VFC open-loop , CFC open-loop
Wait time between two mains switch on cycles	60 s for all devices in normal operating cycle
Interfaces	<i>Standard</i> RS485 (USS) (for parameterisation boxes only) RS232 (Single Slave) System bus <i>Optional</i> AS-I on board (📖 <a href="#">BU0180</a> ) Various bus modules (📖 <a href="#">BU0180</a> )
Electrical isolation	Control terminals
Connecting terminals, electrical connection	<i>Power unit</i> (chapter 2.3.2) <i>Control unit</i> (chapter 2.3.3)

## 8 Additional information

Additional information relating to the operation of the frequency inverter, such as

- EMC
- Derating
- Standardisation of setpoint / target values

can be found in the main instructions for the frequency inverter

## 9 Maintenance and servicing information

### 9.1 Maintenance Instructions

NORD frequency converters are *maintenance free* provided that they are properly used (please see chapter 7 "Technical data").

#### Dusty environments

If the device is being used in a dusty environment, the cooling-vane surfaces should be regularly cleaned with compressed air.

#### Long-term storage

The device must be regularly connected to the supply network for at least 60 min.

If this is not carried out, there is a danger that the device may be destroyed.

If a device is to be stored for longer than one year, it must be recommissioned with the aid of an adjustable transformer before normal connection to the mains.

#### *Long-term storage for 1 - 3 years*

- 30 min with 25 % mains voltage
- 30 min with 50 % mains voltage
- 30 min with 75 % mains voltage
- 30 min with 100 % mains voltage

#### *Long-term storage for >3 years or if the storage period is not known:*

- 120 min with 25 % mains voltage
- 120 min with 50 % mains voltage
- 120 min with 75 % mains voltage
- 120 min with 100 % mains voltage

The device must not be subject to load during the regeneration process.

After the regeneration process, the regulations described above apply again (at least 60 min on the mains 1x per year).

---

#### Information

#### Accessories

The regulations for **long-term storage** apply to the accessories, such as 24 V power supply modules (SK xU4-24V-..., SK TU4-POT-...), and the electronic brake inverter (SK CU4-MBR) likewise.

---

## 9.2 Service notes

Out technical support is available to reply to technical queries.

If you contact our technical support, please have the precise device type (rating plate/display), accessories and/or options, the software version used (P707) and the series number (name plate) at hand.

The device must be sent to the following address if it needs repairing:

**NORD Electronic DRIVESYSTEMS GmbH**  
 Tjüchkampstraße 37  
 D-26605 Aurich, Germany

Please remove all non-original parts from the device.

No guarantee is given for any attached parts such as power cables, switches or external displays.

Please back up the parameter settings before sending in the device.

<b>i Information</b>	<b>Reason for return</b>
	<p>Please note the reason for sending in the component/device and specify a contact for any queries that we might have.</p> <p>You can obtain a return note from our web site (<a href="#">Link</a>) or from our technical support.</p> <p>Unless otherwise agreed, the device is reset to the factory settings after inspection or repair.</p>

<b>i Information</b>	<b>Possible Consequential Damage</b>
	<p>In order to rule out the possibility that the cause of a device fault is due to an optional module, the connected optional modules should also be returned in case of a fault.</p>

### Contacts (Phone)

<b>Technical support</b>	During normal business hours	+49 (0) 4532-289-2125
	During normal business hours	+49 (0) 180-500-6184
<b>Repair inquiries</b>	During normal business hours	+49 (0) 4532-289-2115

The manual and additional information can be found on the Internet under [www.nord.com](http://www.nord.com).



## Key word index

### A

Address ..... 64

#### Assembly

SK 1x0E ..... 19

ATEX ..... 11, 15, 29

Optional ATEX modules ..... 30

#### ATEX

ATEX Zone 22, Cat. 3D ..... 29

#### ATEX

EU conformity declaration ..... 34

#### ATEX

ATEX Zone 22, Cat. 3D ..... 35

### B

Brake chopper ..... 22

Braking resistor ..... 22

### C

#### conformity declaration

ATEX ..... 34

Contact ..... 64

Control connection ..... 26

Control options ..... 37, 44, 51

Control terminals ..... 28

Control unit connection ..... 26

### D

Derating ..... 19

DIP switches ..... 42

Display ..... 37

Dynamic braking ..... 22

### E

EAC Ex ..... 11, 15, 29, 35

Certificate ..... 36

EMC Directive ..... 25

Error messages ..... 50, 51

#### EU conformity declaration

ATEX ..... 34

### F

Factory settings ..... 40

### FAQ

Operational problems ..... 59

Faults ..... 50, 51

Features ..... 7

### I

Installation altitude ..... 61

Internet ..... 64

IP protection class ..... 18

### L

LEDs ..... 50, 51

### M

Maintenance ..... 63

Menu group ..... 45

Messages ..... 50, 51

Motor data ..... 40

### N

Name plate ..... 16

### O

Operating status ..... 50, 51

Operation ..... 37

Overtoltage switch-off ..... 22

### P

Parametrisation options ..... 37, 44, 51

### R

Repairs ..... 64

Retrofitting the device ..... 21

### S

Service ..... 64

SK BRE4- ..... 23

SK BREW4- ..... 23

SK BRI4- ..... 22, 23

SK BRW4- ..... 23

SK CU4-POT ..... 39

Storage ..... 63

Support ..... 64

Switch-on cycles ..... 61

<b>T</b>		<b>V</b>	
Technical data .....	19, 25, 61, 63	Ventilation .....	19
Technical Data		<b>W</b>	
Frequency inverters .....	61	Warning messages .....	56
Total currents .....	26	Warnings .....	50, 51, 56
Type code .....	16	Wiring guidelines .....	24
Type plate .....	40		



## **NORD DRIVESYSTEMS Group**

**Headquarters and Technology Centre**  
in Bargteheide, close to Hamburg

**Innovative drive solutions**  
for more than 100 branches of industry

**Mechanical products**  
parallel shaft, helical gear, bevel gear and worm gear units

**Electrical products**  
IE2/IE3/IE4 motors

**Electronic products**  
centralised and decentralised frequency inverters,  
motor starters and field distribution systems

**7 state-of-the-art production plants**  
for all drive components

**Subsidiaries and sales partners**  
**in 89 countries on 5 continents**  
provide local stocks, assembly, production,  
technical support and customer service

**More than 3,600 employees throughout the world**  
create customer oriented solutions

[www.nord.com/locator](http://www.nord.com/locator)

### **Headquarters:**

**Getriebebau NORD GmbH & Co. KG**  
Getriebebau-Nord-Straße 1  
22941 Bargteheide, Germany  
T: +49 (0) 4532 / 289-0  
F: +49 (0) 4532 / 289-22 53  
[info@nord.com](mailto:info@nord.com), [www.nord.com](http://www.nord.com)

**Member of the NORD DRIVESYSTEMS Group**

