

Intelligent Drivesystems, Worldwide Services



G2122

Explosion Protection



DRIVESYSTEMS

Contents

Introduction

Country-specific explanations	A	2 - 14
General Dust Explosion Protection	B	1 - 8
Motors for Dust Explosion Protection	C	1 - 24
General Gas Explosion Protection	D	1 - 8
Motors for Gas Explosion Protection	C	1 - 8
General Explosion Protected Gear Units	F	1 - 10
Hybrid Mixtures	G	1 - 2
Cooling systems for gear units	H	1 - 2
Decentralised inverters and starters	I	1 - 4
Documentation	J	1 - 8



DRIVESYSTEMS

www.nord.com



Headquarters and Technology Centre

- in Bargteheide, near Hamburg

Industrial gear units

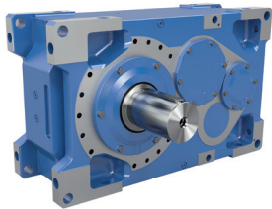

Gear unit motors

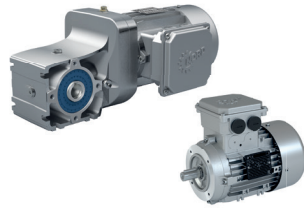

Electronic products

Frequency inverters, motor starters and field distributors



Innovative drive solutions

- for more than 100 branches of industry



Gear unit production



Motor production



Inverter production

7 production locations with cutting edge technology

- Produce gear units, motors, inverters, etc. for complete drive solutions from a single source



The map shown above is for information only and does not claim to be created for or applicable to any legal purpose. For this reason, we do not assume any liability for legality, correctness and completeness.

Subsidiaries and sales partners in 98 countries on 5 continents

- Provide local supplies
- Assembly centres
- Technical support
- and customer service

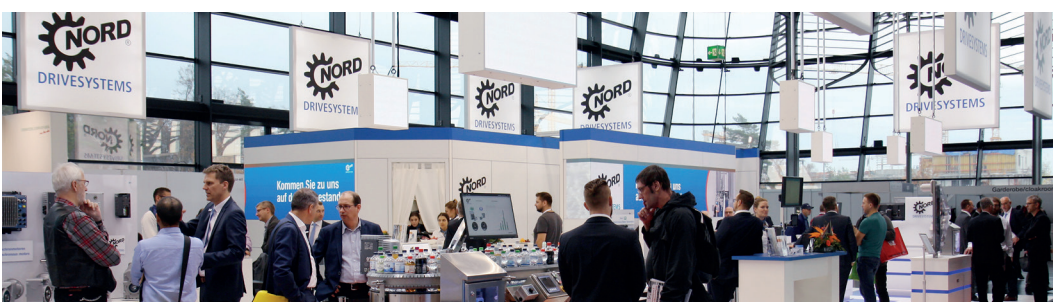

More than 4,000 employees worldwide

- Create customised solutions

For many decades, NORD DRIVESYSTEMS has supplied drive units for use in potentially explosive environments. Since 2003 this range has also included specially designed gear units which comply with EU Ex directives (ATEX).

Over the past years a great deal of work has been invested in order to comply with other international regulations such as IEC Ex, EAC Ex as well as the specifications for the North American market.

This catalogue contains information about gear units, motors and inverters for use in gas or dust explosion protection.

The catalogue has a modular structure and if necessary can be compiled separately for gas or dust areas.

In addition, this catalogue provides a large amount of additional technical information and supplements catalogues

- catalogues G1000 (Geared Motors) and M7000 (Motors)
- the operating instructions B2000 for gear units and B1091 or B1091-1 for motors.

This catalogue provides assistance for use of software tools such as myNORD and NORDcad. The myNORD tool enables quick and simple verification of whether a particular drive is Ex compliant.

Certificates and declarations of conformity can be found on our homepage www.NORD.com
- see ⇒ chapter **Documentation** 📖 Page J 6-7

The nameplates shown in this catalog are examples only.
NORD Drivesystems assumes no responsibility for the up-to-dateness of the data contained on the nameplates.

Throughout the world; states, confederations of states or organisations define the technical requirements and the necessary standards for explosion protected devices.

The resulting variety is a barrier to trade and places great demands on globally active manufacturers. As a result, harmonized technical standards have been used to define uniform, supraregional standards. These are also used by countries which themselves have no individual legal regulation regarding explosion-protected drives.

NORD DRIVESYSTEMS is a globally active company which is able to produce motors, gear units and frequency inverters according to various Ex standards. To enable this, it cooperates closely with the DEKRA EXAM GmbH as well as with the Physikalisch-Technischen Bundesanstalt PTB and other international institutions.

Conformity of the products as well as production and quality control are ensured by regular audits, which are performed by the PTB as well as the company NANIO CCVE. This is completed by a wide range of examination of motors and gear units by the responsible bodies worldwide.

In addition to fulfilling purely technical specifications, the corresponding labelling of drive units as well as provisions of the required specific documentation is of great importance. This enables NORD DRIVESYSTEMS not only to ensure the safe operation of plant and machinery with its specific products, but also the simple and smooth import of products into designated countries.

In the following sections of this Ex catalogue, products are differentiated according to the type of their certification. Four major acceptance systems are described in greater detail below.

Due to the complexity of this topic and for reasons of clarity, the following overview describes the facts which relate to selected products from NORD DRIVESYSTEMS. It does not claim to be complete or fully up-to-date.



European Union "ATEX"

For many decades, the EU has been using the ATEX technical standards to ensure the safe operation of machinery and equipment.

With its Ex specifications for mechanical devices regarding the former Directive 94/9/EG the EU acted as a pioneer at that time.

Scope of Application **EU member states + others such as Norway and Switzerland**

Basis Technical standards based on IEC standards
(IEC - International Electrotechnical Commission)

Based on ... Directive 2014/34/EU relates to mechanical and electrical devices for use in explosion hazard areas.
(In addition to this directive, which directly relates to explosion protection, the Ecodesign, EMC and RoHS directives must also be complied with).

Ex standards

- for motors

- DIN EN 60079-0, DIN EN 60079-7, DIN EN 60079-31

- for inverters + starters

- DIN EN 60079-0:2012, DIN EN 60079-31:2019, DIN EN ISO 80079-36, DIN EN ISO 80079-37

- or gear units

- DIN EN ISO 80079-36:2016, DIN EN ISO 80079-37:2016

Documents

The suitability of the device for explosion protection is documented by:

- Type Test Certificate and Declaration of Conformity for Category 2 motors
- Declaration of Conformity for Category 3 motors
- Declaration of Conformity for gear units
- Official bodies involved:
 - Physikalisch-Technischen Bundesanstalt PTB
 - DEKRA EXAM

Audits: The production and quality control of NORD DRIVESYSTEMS is audited at regular intervals by a Notified Body according to the regulations of EU 2014/34.

Energy efficient motors

Energy efficiency requirements for motors:

According to Regulation 640/2009 motors for explosion protection (gas and dust) constitute an exception and are therefore not subject to requirements with regard to this. However, customers are increasingly specifying the use of IE2 and IE3 motors.



IECEX

IECEX approval can be helpful for the approval of explosion protected electrical equipment according to national standards.

Australia and New Zealand

Technical standards based on IEC standards
(International Electrotechnical Commission)

IECEX 01 IEC Scheme for the Certification to Standards for Electrical Equipment for "Explosive Atmospheres (IECEX Scheme) - Basic Rules" and

IECEX 02 IEC Scheme for the Certification to Standards for Electrical Equipment for "Explosive Atmospheres (IECEX Scheme) - Rules of Procedure"

- IEC 60079-0 Explosive atmospheres
- Part 0: Equipment - General requirements
- IEC 60079-31 Explosive atmospheres
- Part 31: Equipment dust ignition protection by enclosure "t"
- ISO 80079-36 Non-electrical equipment for explosive atmospheres - Basic method and requirements
- Part 36:
- ISO 80079-37 Non-electrical equipment for explosive atmospheres - Non electrical type of protection constructional safety "c", control of ignition source "b", liquid immersion "k"
- Part 37:
- Official bodies involved:
- DEKRA EXAM and PTB

Audits: IECEX audits by Ex- testing laboratories and (Ex-certification bodies) are mandatory. Performed by the PTB as the notified body.

Energy efficiency requirements for motors:

From the point of view of the IECEX there are neither requirements nor restrictions with regard to energy efficiency classes. NORD supplies motors with efficiency classes IE1 and IE2 with IECx approval.

Currently, Getriebebau NORD does not offer EX gear units according to IECEX. A combination of an IECEX motor and a gear unit, complying with EU standard, is possible, see ⇒  page 4.

Scope of Application

Basis

Based on ...

Ex standards - for motors

- for gear units

Documents

Energy efficient motors

Notice

EAC EX

EAC (abbreviation for EurAsian Conformity) is a label which states that a product complies with the specifications of the Eurasian Economic Union regarding to technical specification, labelling and documentation.

EAC Ex indicated conformity with the standard **TR CU 012/2011** ¹⁾ "On safety of equipment intended for use in explosive atmospheres". This contains technical specifications which are largely based on the IEC Ex as well as standards which are used in the EU.

Certified NORD products

The conformity certification is completed in the form of a declaration and certification. NORD products, their production and quality management have been accepted and approved by the certifying body NANIO CCVE. The corresponding certificates can be found under www.nord.com **Documentation / Certificates**.

1) TRCU means "The technical regulation of the customs union" in Cyrillic script "TP C"

Scope of Application

Russia, Belarus, Armenia, Kazakhstan and Kyrgyzstan

Basis

TR CU 012/2011 "On safety of equipment intended for use in explosive atmospheres". Technical standards based on IEC (International Electrotechnical Commission) standards. In particular IEC 60079 and IEC 80079.

Products from NORD DRIVESYSTEMS compliant with EAC Ex are tested and produced in a similar manner to products according to Directive 2014/34/EU ATEX.

The technical data of the motors correspond to that of ATEX motors used in Europe - see ⇒  C1-2.

Standards for NORD EX motors

Applied standards for NORD EX motors

ГОСТ Standard	IEC Standard
ГОСТ 31610.0-2014	IEC 60079-0:2011
ГОСТ Р МЭК 60079-31-2013	IEC 60079-31:2013
ГОСТ Р МЭК 60079-7-2012	IEC 60079-7:2006
ГОСТ 31610.15-2014	IEC 60079-15:2010



This results in comprehensive product labelling which is illustrated with the following example for a drive which is to be operated in a dust Ex atmosphere corresponding to Zone 22.

Type plate on the gear unit

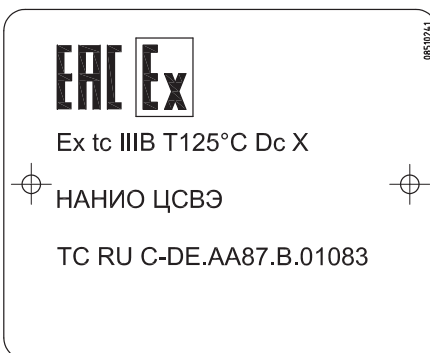
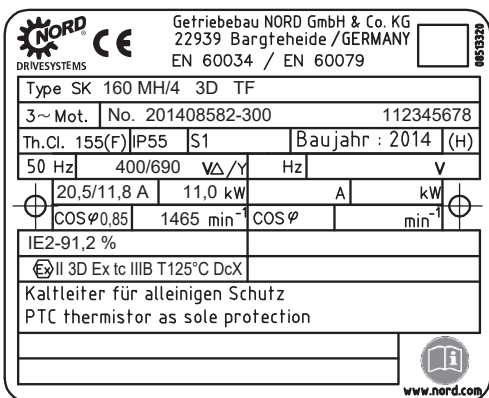
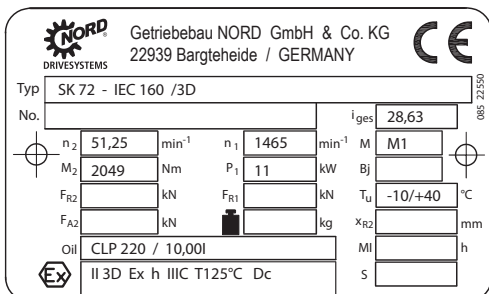

ПРЕДУПРЕЖДЕНИЕ ! ОТКРЫВАТЬ, ОТКЛЮЧИВ Т СЕТИ



Ex II 3D Ex tc IIIB T125°C Dc X



Packaging

Energy efficiency requirements for motors:

Energy efficient motors

From the point of view of the EAC Ex there are neither requirements nor restrictions with regard to energy efficiency classes. NORD supplies motors with efficiency classes IE1 and IE2 with EAC Ex approval.

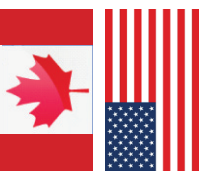

Specific national regulations



Introduction



Canada CEC

- With the 2015 version of the Canadian Electrical Code (CEC) the IEC concept based on zones was adopted: ⇒ A5, IEC Ex
 - Repairs and extensions of existing systems may continue to be carried out in accordance with the requirements of the division system. ⇒ A8, HazLoc
 - Article 18-000, Annex J (see also NEC 500)

CEC

Canadian Electrical Code

CEC in Canada – with CEC 2015 several articles have been completely revised or deleted entirely!

Article	Contents
18-000	Description of scope of application
18-002	Definition of hazard areas
18-004	Classification of gases and dusts
18-006	Classification of gases – Zone 0, 1 and 2
18-008	Classification of dusts – Zone 20, 21 and 22
18 -Annex J	Classification according to the division system for existing plants

The zone system according to IEC Ex protection is mandatory for all new installations as of 2015!

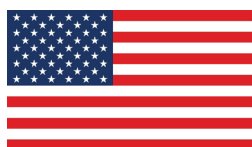

Hazloc - Explosion protection in North America

Unlike in many other parts of the world, the explosion protection in the US is not based on IEC specifications.

With a similarly high safety level, this results in specific technical solutions as well as a separate categorisation of technical devices with regard to the corresponding explosive environment and the explosive mixture.

The specifications for electrical equipment originate from the NEC The National Electrical Code (NEC) is a safety standard of the United States of America.

This formulates the specifications for the design of electrical installations.

Unlike e.g. in Europe, devices are not categorised according to their use, but rather into "Classes" and "Divisions". In the USA the term "Hazloc" is used in a similar manner to "ATEX" in Europe.

Safety standard NEC

HazLoc

Scope of Application

USA (and Canada for existing plants)

Basis

USA: NEC National Electrical Code
(Canada: CEC Canadian Electrical Code)

In 1996, the IEC classification system (categorisation according to zones) was also introduced for Class I. This change was made by Article 505 of the NEC, which gives the user the opportunity to choose the system that is technically and economically optimal for their purposes.

In 2005 Zones 20, 21 and 22 for areas with flammable dust (Article 506) were introduced.

NEC

National Electrical Code

NEC in the USA	
Article	Contents
500	General requirements for Class I, II and III Divisions
501	Requirements for Class I Divisions
502	Requirements for Class II Divisions
503	Requirements for Class III Divisions
504	Requirements for Class I, II and III Divisions with regard to intrinsic safety (IS)
505	General and specific requirements for Zone 0, 1 and 2
506	General and specific requirements for Zone 20, 21 and 22



Class I - Gas groups A, B, C and D

Class I

- Gases, vapours or aerosols
- NEC 500 / (CEC 18-000J for Canada up to 2015)
- Division 1
Areas in which hazardous concentrations of flammable gases or vapours
 - Can be present under normal operating conditions,
 - Can frequently occur during repair and maintenance work,
 - Can occur throughout malfunctions concerning operation. During which, errors occurring in electrical equipment may result in a source of ignition.
- Division 2
 - Areas in which hazardous concentration of flammable gases or vapours are kept in closed containers or systems and can only be released under fault conditions.

Class II - Dust groups E, F and G

Class II

- Dusts
- NEC 500 / (CEC 18-000J for Canada up to 2015)
- Division 1
Areas in which hazardous concentration of explosive dust atmospheres
 - Can be present under normal operating conditions,
 - Can occur throughout malfunctions concerning operation. During which, errors occurring in electrical equipment may result in a source of ignition.
 - Areas with hazardous quantities of conductive dust (Group E).
- Division 2
 - Areas in which hazardous concentrations of explosive dust atmospheres can only be released under fault conditions.

Class III

Class III

- Ignitable fibers and flyings
- NEC 500 / (CEC 18-000J for Canada up to 2015)
- Division 1
 - Areas in which flammable fibres and lint are caused or are processed.
- Division 2
 - Areas in which flammable fibres are stored or handled in a different manner to that in the production process.

Specific national regulations

Comparison of IEC and US explosion protection

Zone 20	Zone 21	Zone 22
is an area in which hazardous explosive atmospheres in the form of a cloud of flammable dust is present in the air constantly, for long periods or frequently.	is an area where it is likely that an explosive atmosphere in the form of a cloud of flammable dust will occasionally occur during normal operation.	is an area where it is likely that an explosive atmosphere in the form of a cloud of flammable dust only occurs in the air for a short period during normal operation.
Division 1		Division 2
is an area in which hazardous concentrations of explosive dust atmospheres <ul style="list-style-type: none"> - Can be present under normal operating conditions, - Can occur throughout malfunctions concerning operation. During which, errors occurring in electrical equipment may result in a source of ignition. 		is an area in which hazardous concentration of explosive dust atmospheres can only be released under fault conditions.

Zone 0	Zone 1	Zone 2
is an area in which the hazardous explosive atmosphere consisting of a mixture of air and flammable gases, vapours or aerosols is present constantly, over long periods or frequently.	is an area in which during normal operation a hazardous atmosphere consisting of an explosive mixture of air and flammable gases, vapours or aerosols can form occasionally.	is an area in which during normal operation a hazardous atmosphere consisting of a mixture of air, flammable gases, vapours or aerosols cannot normally occur, or only occur for short periods.
Division 1		Division 2
is an area in which flammable concentrations or flammable gases aerosols or liquids <ul style="list-style-type: none"> - Probably occur during normal operating conditions - Regularly occur as a result of maintenance or repair work or due to frequent faults. <div style="text-align: center; margin-top: 10px;">  </div>		is an area in which flammable concentrations of flammable gases, aerosols or liquids <ul style="list-style-type: none"> - Probably do not occur during normal operating conditions - Normally occur in closed containers and which can only be released in case of accidents, faults or abnormal operation.

In spite of the same wording, the US temperature classes differ from those which are used in the IEC:

Note

Gas temperature category		
Max. surface temperature	IEC / NEC 505	NEC 500
450°C	T1	T1
300°C	T2	T2
280°C		T2A
260°C		T2B
230°C		T2C
215°C		T2D
200°C	T3	T3
180°C		T3A
165°C		T3B
160°C		T3C
135°C	T4	T4
120°C		T4A
100°C	T5	T5
85°C	T6	T6

For motors, the following specifications apply with regard to energy efficiency classes:

Energy efficient motors

- USA Regulation: Epect 2007 EISA (NEMA MG-1)
- Canada Regulation: CSA C390 (NEMA MG-1)

- Official body involved:
 - UL and CSA

Documents

CCC EX

Since 1.10.2020, all motors in China which are suitable for use in potentially explosive applications need to be subject to CCCex certification. This applies to motors that are imported to China as well as to motors that are put into operation in China. The regulation applies to both gas and dust explosion protection and all zones.

Regulation

CNCA-C23-01:2019 - Compulsory Certification Rules - Explosion protected electrical equipment (also called 'CCC Ex').

Certified NORD products

NORD motors have been accepted and approved by the China Quality Certification Centre. The corresponding certificates can be found under www.nord.com **Documentation / Certificates**.

Scope of Application **China**

Basis

Products from NORD DRIVESYSTEMS compliant with CCC Ex are tested and produced in a similar manner to products according to Directive 2014/34/EU ATEX.

The technical data of the motors correspond to that of ATEX motors used in Europe - see ⇒  C1-2.

Availability

NORD offers a CCCex certificate for the following Ex-motors from our own production:

- Zone 21, equipment category 2D, Ex tb 125°C
- Zone 22, equipment category 3D, Ex tb 125°C
- Integral Mounting and IEC interface
- Efficiency class IE1 / IE2 (from 80SH/4)
- Size 63-180
- Frequency 50/60 Hz
- DOL and inverter duty
- IP Protection Class IP55 for Zone 22
- IP Protection Class IP66 for Zone 21

Restrictions

Motortype	Explanation	CCCex	EACex	ATEX	IECex	HazLoc
2D	Europe category 2D	--	optional	o.K.	--	--
3D	Europe category 3D	--	optional	o.K.	--	--
ID2	US / Canada Class I Division 2	--	--	--	--	o.K.
IID2	US / Canada Class II Division 2	--	--	--	--	o.K.
C2D	China category 2D	o.K.	--	o.K.	--	--
C3D	China category 3D	o.K.	--	o.K.	--	--
IDB	IECex category 2D	--	--	--	o.K.	--
IDC	IECex category 3D	--	--	--	o.K.	--

-- : not available

o.K.: always additionally marked when selecting a CCCex motor

optional: possible in addition to ATEX or CCCex

Options

RD	Protective Shield
WE	2. Shaft End
TF	Thermistor, PTC resistor
KB	Closeable condensation hole
BRE	Brake (only C3D)







The motors are equipped with two additional nameplates and are therefore suitable for operation in Europe (ATEX) and China (CCCex)

Examples





Introduction

2D Motor

  防爆电机				08514200					
Type SK 90LH/4 C2D TF		2020							
3 ~ Mot. No. 200788472-200		12345678							
Th.Cl. 155 (F)	S1	Tamb -20°C to +40°C		GYJ20.1216					
Ex tD A21 IP66 T125°C		GB12476.1-2013 GB12476.5-2013							
INVERTER OUT Y	Hz	3	20	50	70	r/min	1420	LINE OPERATING TION	
	Nm	6,00	9,80	10,1	9,00	kW	1,5		
	r/min	33	521	1390	1950	V	230/400 Δ / Y		
	kW	0,02	0,53	1,47	1,83	Hz	50		
	V Y	35	174	361	361	A	5,85/3,38		
	A	2,38	3,28	3,30	4,00	cos φ	0,79		
16,8 kg									
由变频器供电		f _{max} 100 Hz		f _{p min} 4 kHz		PWM			
Getriebbau NORD GmbH & Co. KG, 22939 Bargteheide / 德国				www.nord.com					

3D Motor

Type plate on the motor

  防爆电机				02514210					
Type SK 90LH/4 C3D TF		2020							
3 ~ Mot. No. 200788472-300		12345679							
Th.Cl. 155 (F)	S1	Tamb -20°C to +40°C		GYJ20.1216					
Ex tD A22 IP66 T125°C		GB12476.1-2013 GB12476.5-2013							
INVERTER OUT Y	Hz	3	20	50	70	min ⁻¹	1415	LINE OPERATING TION	
	Nm	6,00	9,80	10,1	9,00	kW	1,5		
	r/min	33	521	1390	1950	V	230/400 Δ / Y		
	kW	0,02	0,53	1,47	1,83	Hz	50		
	V Y	35	174	361	361	A	8,8/3,35		
	A	2,38	3,28	3,30	4,00	cos φ	0,79		
16,8 kg									
由变频器供电		f _{max} 100 Hz		f _{p min} 4 kHz		PWM			
Getriebbau NORD GmbH & Co. KG, 22939 Bargteheide / 德国				www.nord.com					





Basic information regarding European dust explosion protection

General

Explosive dust atmospheres occur in various areas of industry and crafts. They are usually caused by mixtures of oxygen in combination with circulating or deposited amounts of ignitable dust. Electrical and mechanical equipment for use in explosion hazard areas is subject to special national and international standards and directives.

Explosion protection prescribes rules which have the objective of protecting people and objects from possible explosion hazards.

Integrated explosion protection specifies that the measures for explosion protection must be carried out in a defined sequence:

- Rules of conduct to prevent the occurrence of explosive atmospheres
- Avoiding ignition of explosive atmospheres
- Limiting the effect of an explosion to a safe level

In the design of mechanical and electrical equipment the objective is to prevent ignition or to restrict its effects. For this, the explosion protection regulations come into effect

The term ATEX, which is often used for explosion protection comes from the initial letters of an older French directive "**A**tmosphères **E**xplosives". Current European explosion protection regulations are based on Directive 2014/34/EU as the successor of the previously valid EU Directive 94/9/EC. This Directive serves for the harmonisation of statutory regulations of member states for devices and protective systems for proper use in explosion hazard areas. This Directive is also known as the "Manufacturer Directive" in order to differentiate it from Directive 1999/92 EC which provides information regarding health and safety requirements for workers as well as details of categorisation according to zones.

EU Directive

Harmonised standards are used to meet basic safety and health requirements, some of which are exemplified below

Standards for electrical devices:

- DIN EN 60 079 - 0 General Regulations
- DIN EN 60 079 - 31 Dust explosion protection with housing "t"

- for electrical
devices

Standards for mechanical devices:

- DIN EN ISO 80079-36:2016 Basics and requirements
- DIN EN ISO 80079-37:2016 Protection by constructional Safety

- for mechanical
devices

Device groups

Device groups

Directive 2014/34 EU differentiates between two groups of devices:

- **Group I** devices - indicate equipment which is particularly suitable for mining with device categories M1 and M2
- **Group II** devices - are suitable for use in other areas which may be endangered by an explosive atmosphere

For most applications the Ex protection data on the gear unit type plate begins with **II**, so that the special features of Group I systems are not considered further here.



„ATEX“ Dust explosion protection

Standards - for motors

While Directive 2014/34 EU differentiates between two groups of devices I and II, it is further sorted into Groups I, II and III on the basis of DIN EN 60079-0 and -31 standards applicable to motors.

- **Group II** - indicates devices for mining
- **Group II . .** - indicates devices for gas explosion protection
- **Group III. .** - indicates devices for dust explosion protection

Zone

Zone

The categorisation into zones is dependent on specific conditions of the workplace – please refer to the stipulations in Directive 1999/92/EC with regard to the frequency of occurrence of dust.

- Zone 21

Zone 21:

The area in which an explosive atmosphere consisting of a mixture of air and inflammable dust can occasionally form during normal operation.

- Zone 22

Zone 22:

The area in which, during normal operation, an explosive atmosphere in the form of a cloud of combustible dust in the air normally does not occur, and if so, only rarely or for a short time.

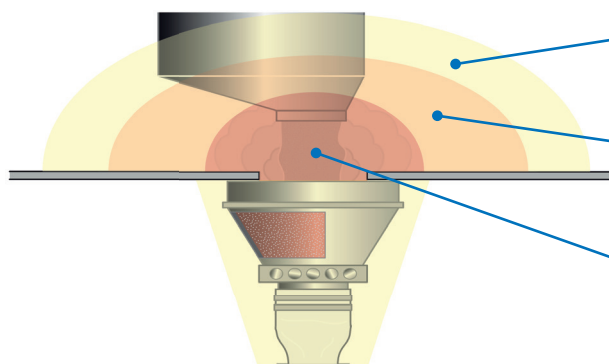

Zone 22:

Rare occurrence of explosive atmospheres

Zone 21:

Occasional occurrence of explosive atmospheres

Zone 20:

Constant or frequent occurrence of explosive atmospheres

gear units

A gear unit ordinarily becomes an explosion-protected system due to a constructionally safe design, use of specific Ex special parts as well as extensive documentation. For technical requirements of components, please refer to the highly informative DIN EN ISO 80079-37:2016.

Temperature details, e.g.: "125°C"

The Ex protection details on the type plate of Dust Ex drive units provide information about the maximum surface temperature of the device in degrees Celsius.



This is the total of the ambient temperature, the heating as a result of operation as well as safety reserves.

Standard limit value 125°C [140°C]

For most dust-air mixtures in the industry, this temperature is sufficient and practicable. In spite of this, an individual examination must be made for each individual application.



Dust explosion protection device labelling

Workplace	Presence of an explosive dust atmosphere	occasionally	rarely or for short periods	
	Zone	21	22	
	Dust type	all types	Electrically conducting	Electrically non-conducting
Device labelling	Device group according to 2014/34/EU	II		
	Group according to DIN EN 60079-0	IIIC	IIIC	IIIB
	Device category	2D	3D	3D
	Equipment Protection Level EPL according to DIN EN 60079	Db	Dc, Dc	Dc, Dc
	Protection class	IP 65	IP65	IP55
	Max. permissible housing temperature 125°C or 140°C			
	Certificate	EC Type Test Certificate, EC Declaration of Conformity on the basis of an EC Type Test Certificate	EC Declaration of Conformity	
	Labelling according to 2014/34 EU	 II 2D	 II 3D	 II 3D
	Labelling according to DIN EN 60079-0 DIN EN 60079-31	e. g.: II 2D Ex tb IIIC T125°C Db	e. g.: II 3D Ex tc IIIC T125°C Dc	e. g.: II 3D Ex tc IIIB T125°C Dc
Labelling according to 2014/34/EU for gear units	II 2D Ex h IIIC T125°C Db	II 3D Ex h IIIC T125°C Dc	II 3D Ex h IIIB T125°C Dc	

Drive dimensioning

The applications of our customers place a wide variety of demands on ATEX compliant operation. We are happy to consider these requirements in the drive design and thus contribute to the safe and reliable operation of systems and machinery. Documentation of special requirements is made on the type plate of the gear unit → Section "Explosion Protected Gear Units in General" or in the special documentation enclosed with the standard documentation.

ATEX LABELLING DUST FOR MOTORS



II 3D Extc IIIB T125°C Dc X

Dust explosion protection

Labelling and categorisation of explosive environment									
Type of material	Frequency of occurrence of flammable material	Categorisation of explosive environment	Labelling of equipment			EPL - Equipment protection level			
			Device group	Device category					
Dusts	Constantly or frequently present	Zone 20	II	1D	2D	3D	Da	Db	Dc
	Occasionally present	Zone 21	II						
	Rarely present (short periods)	Zone 22	II						

Type of ignition protection for electrical devices				
Protection principle	Type of ignition protection	Identification	Use in zone	Standard
Protection with housing	Dust explosion protection	ta tb tc	20 21 22	EN60079-31

Explosion group		
Explosion group Dust		Examples
IIIA	IIIB	Flammable lint
	IIIC	Non-conductive dust
		Conductive dust

Surface temperature
Maximum surface temperature of equipment in degrees Celsius

Additional information	
X	Note any special conditions or restrictions – refer to the operating and installation instructions

ATEX LABELLING DUST FOR GEAR UNITS

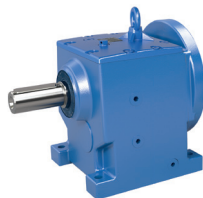

II 3D Exh IIIC T125°C Dc

Dust explosion protection

Labeling and categorisation of explosive environment					
Type of material	Frequency of occurrence of flammable material	Categorisation of explosive environment	Labelling of equipment		EPL - Equipment protection level
			Device group	Device category	
Dusts	Constantly or frequently present	Zone 20	II	1D 2D 3D	Da Db Dc
	Occasionally present	Zone 21	II		
	Rarely present (short periods)	Zone 22	II		

Exh Labelling of mechanical devices according to DIN EN ISO 80079-36

Explosion group		
Explosion group Dust		Examples
IIIA	IIIB	suitable for flammable suspended matter
	IIIC	suitable for flammable suspended matter and non-conductive dust
	IIIC	suitable for flammable suspended matter, non-conductive dust and conductive dust

Surface temperature
Maximum surface temperature of equipment in degrees Celsius





Motors for dust explosion protection according to Directive 2014/34/EU

The motors listed in the following are explosion protected motors from our own production, which can be fitted NORD gear units either directly or by means of an IEC or NEMA cylinder.

There are two versions which are suitable for mains or inverter operation, which are available as follows:

Mains or inverter operation

- Version 2D for Zone 21
- Version 3D for Zone 22 non-conducting dust

The maximum surface temperature is normally 125°C, but may also be 140°C in specially marked exceptions.

Dust explosion protection

Motor energy efficiency standard:

ATEX 2D (conducting and non-conducting dust)

ATEX 3D (non-conducting dust)

1500 rpm	230/400 V & 400/690 V	Ex II 2D IP 66 T 125°C
50 Hz	4-pole	Ex II 3D IP 55 T 125°C

		S1											
Type		P _N	n _N	M _N	I _N		cos φ	η	M _A /M _N	M _K /M _N	I _A /I _N	J	kg
		[kW]	[rpm]	[Nm]	230/400 V	400/690 V		4/4xP _N				[kgm ²]	[kg]
					[A]	[A]		[%]					
63	S/4	0,12	1385	0,83	0,88/0,51		0,62	50,5	2,8	2,8	3,26	0,00021	3,6
63	L/4	0,18	1368	1,26	1,13/0,65		0,66	58,1	2,5	2,6	3,38	0,00028	4,2
71	S/4	0,25	1365	1,75	1,28/0,74		0,80	61,5	1,8	1,9	3,97	0,00072	5,4
71	L/4	0,37	1385	2,55	1,82/1,05		0,76	65,8	2,2	2,4	4,50	0,00086	6,3
80	S/4	0,55	1385	3,79	2,62/1,51		0,75	75,1	1,9	2,0	4,11	0,00109	8,0
80	L/4	0,75	1395	5,13	3,52/2,03		0,75	75,5	2,0	2,1	4,17	0,00145	9,0
90	S/4	1,1	1410	7,45	4,78/2,76		0,76	77,6	2,3	2,6	5,26	0,00235	12
90	L/4	1,5	1390	10,30	6,11/3,53		0,78	77,5	2,3	2,6	5,84	0,00313	14
100	L/4	2,2	1415	14,85	8,65/5,00	5,0/2,89	0,78	80,8	2,3	3,0	5,76	0,0045	18
100	LA/4 ¹⁾	3,0	1415	20,25	11,76/6,80	6,80/3,93	0,78	83,3	2,5	2,9	6,32	0,006	21

* Version B5, without options

¹⁾ Deviating surface temperature T 140°C

ATEX 2D

ATEX 3D

Name plates

Gefriebebau NORD GmbH & Co. KG 22939 Bargteheide / GERMANY EN 60034 / EN 60079	
Type SK 80S/4 2D TF	
3~Mot. No. 201408582-300	20174276
Th.Cl. 155 (F) IP 66 S1	Baujahr : 2020 (H)
50 Hz 230/400 V Δ/Y	Hz V
2,62/1,51 A 0,55 kW	A kW
COS φ 0,75 1385 min ⁻¹	COS φ min ⁻¹
Ex II 2D Ex tb IIC T125°C Db BVS 04 ATEX E037 X Kaltleiter fuer alleinigen Schutz PTC thermistors as sole protection	

Gefriebebau NORD GmbH & Co. KG 22939 Bargteheide / GERMANY EN 60034 / EN 60079	
Type SK 80L/4 3D TF	
3~Mot. No. 201408882-100	20186303
Th.Cl. 155 (F) IP 55 S1	Baujahr : 2020 (H)
50 Hz 230/400 V Δ/Y	Hz V
3,52/2,03 A 0,75 kW	A kW
COS φ 0,75 1395 min ⁻¹	COS φ min ⁻¹
Ex II 3D Ex tc IIB T125°C Dc Kaltleiter fuer alleinigen Schutz PTC thermistors as sole protection	



Dust Explosion protection „ATEX“



Motor energy efficiency: High IE2 / Premium IE3

ATEX IE2 2D (conducting and non-conducting dust)

ATEX IE2 3D (non-conducting dust)

1500 1/min 230/400 V & 400/690 V
50 Hz 4-pole

Dust explosion protection

		IE2 / S1													
Type		P _N [kW]	n _N [rpm]	M _N [Nm]	I _N		cos φ	η			M _A /M _N	M _K /M _N	I _A /I _N	J [kgm ²]	kg
					230/400 V [A]	400/690 V [A]		φ	1/2xP _N [%]	3/4xP _N [%]					
80	SH/4	0,55	1415	3,71	2,39/1,38		0,73	77,7	80,7	80,8	3,1	3,2	5,5	0,0014	9,0
80	LH/4	0,75	1410	5,08	3,12/1,80		0,74	81,6	83,0	82,4	3,0	3,1	5,7	0,0019	10,2
90	SH/4	1,10	1430	7,35	4,26/2,46		0,79	80,9	82,0	81,8	3,1	3,5	6,5	0,0034	15,1
90	LH/4	1,50	1420	10,09	5,85/3,38		0,78	81,3	82,4	82,2	3,3	3,5	6,7	0,0039	16,8
100	LH/4	2,20	1445	14,54		4,79/2,76	0,77	85,2	86,7	86,6	3,7	4,3	8,2	0,0075	25,2
100	AH/4	3,00	1420	20,18		6,40/3,69	0,80	86,4	86,7	85,6	3,1	3,5	6,9	0,0075	25,2
112	MH/4	4,00	1440	26,53		8,12/4,69	0,83	87,4	87,6	86,7	3,1	3,6	8,0	0,014	35,5
132	SH/4	5,50	1455	36,10		10,82/6,24	0,83	87,6	88,5	88,2	3,1	3,5	8,1	0,032	55,0
132	MH/4	7,50	1460	49,23		15,19/8,77	0,80	88,5	89,5	89,3	3,3	3,9	8,2	0,035	62,0
132	LH/4 ¹⁾	9,20	1450	60,59		19,70/11,39	0,77	87,6	89,7	89,3	3,44	3,84	7,7	0,035	62,0
160	MH/4	11,0	1465	71,70		20,5/11,8	0,85	90,8	91,3	91,2	2,9	3,4	9,1	0,067	93,0
160	LH/4	15,0	1465	97,75		27,5/15,9	0,87	91,7	92,4	92,0	3,0	3,5	9,6	0,092	122
180	MH/4	18,5	1475	120		34,9/20,2	0,84	92,2	92,6	92,2	2,9	3,2	8,3	0,13	137
180	LH/4	22,0	1475	142		40,8/23,6	0,86	92,7	92,9	92,2	2,8	3,1	8,4	0,16	155

		IE3 / S1													
225	SP/4 ²⁾³⁾	37	1485	238	68,9	39,8	0,83			94,1	2,9	3,2	8,43	0,54	330
225	MP/4 ²⁾³⁾	45	1485	289	82,2	47,5	0,84			94,6	3,0	3,4	8,77	0,67	365
250	WP/4 ²⁾³⁾	55	1480	355	96,8	55,9	0,88			94,6	2,6	2,8	7,65	0,82	400

* Version B5, without options ¹⁾ Deviating surface temperature T 140°C ²⁾ only available in 3D ³⁾ only mains operation

Motor options

2D according to Directive 2014/34 EU		3D according to Directive 2014/34 EU	
■ TF	Temperature sensor (Standard)	■ TF	Temperature sensor (Standard)
■ RD	Rain shield	■ RD	Rain shield
■ WE	2nd shaft end	■ WE	2nd shaft end
■ KB	Condensation hole	■ KB	Condensation hole
■ B3	Foot-mounted version	■ B3	Foot-mounted version
■ RLS	Back stop	■ BRE	Brake
		■ F	External fan for sizes 63 to 132:
		■ RLS	Back stop for sizes 80 to 132:

Name plates

ATEX IE2 2D

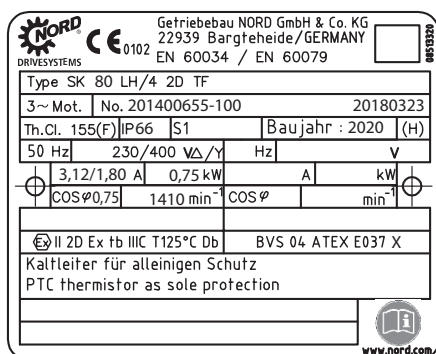

ATEX IE2 3D

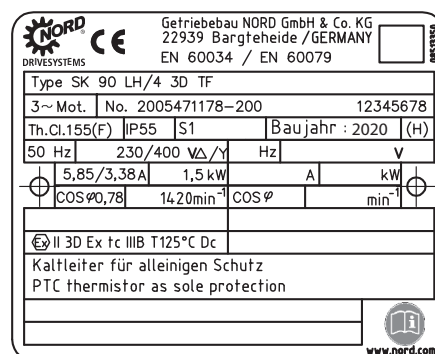

The motors, which comply with the European Directive 2014/34 EU, can be operated in the corresponding design with inverters with frequencies between 3 and 100 Hz. The 50, 87 and 100 Hz characteristic curves can be used. 2D motors for Zone 21 for operation with inverters are always designed for 230/400V in order to enable maximum flexibility.



Planning of motors for NORD decentralised frequency inverters:

When planning, it must be noted that the continuously usable motor torque is governed by two factors:

- By limits which are specific to the motor. These values can be obtained from B1091-1
- By limits which are specific to the frequency inverter. These values can be obtained from G4014-1

The lower of the two continuously usable motor torques as determined above must always be used for planning purposes.

Category 2D and 3D standard motors supplied by NORD DRIVESYSTEMS comply with the standards DIN EN 60079-0 and DIN EN 60079-31.

The insulation of the windings is designed for operation with frequency inverters. For operation with frequency inverters, the motors are always equipped with triple thermistors as per DIN 44082.

For variable speed drives, the thermistor is the most important protective element to ensure compliance with the maximum surface temperature, which is stated on the type plate of the motor.

Planning of motors with control cabinet inverters from NORD DRIVESYSTEMS, or with inverters which fulfil the following criteria:

Necessary frequency inverter characteristics:

- Only frequency inverters with a vector regulation method which provides load-dependent terminal voltage adjustment in the low speed range may be used.
- The maximum output voltage of the frequency inverter must not be less than 91 % of the mains voltage which is stated as the rated voltage on the type plate.
- The frequency inverter must provide $i^2 \cdot t$ monitoring which is adjustable to the rated current for the motor.
- The pulse frequency of the output stage must be adjustable to 4 kHz or higher.
- If the inverter does not have an input for evaluation of the thermistor, evaluation must be carried out by a separate triggering device which switches off the inverter. Operation without evaluation of the thermistor is not permitted.
- Evaluation of the thermistor for motors with ignition protection type tb (Category 2D) must be carried out with an external certified thermistor triggering device with an EU type test certificate.

Thermistor evaluation by the frequency inverter is not permitted. In case of a fault (excessive temperature) the motor and frequency inverter combination must be safely switched off via the external thermistor triggering device.



Dust Explosion protection „ATEX“



Increased ambient temperatures for 3D motors

Operation is possible up to an ambient temperature of 60°C. The stated torques must then be reduced to 72 %. Linear interpolation between adjacent frequencies is permissible.

Continuously usable torques for operation with control cabinet inverters e.g. SK 500E

Torques with use of the 50 Hz characteristic curve for 2D and 3D motors without external fan

Motor type / Circuit type	Category	3	20	40	60	100	f _s [Hz]
63S/4 230/400V, 50 Hz Y circuit	2D/3D	0,65	0,86	0,86	0,86	0,54	M [Nm]
	2D/3D	0	450	1073	1484	1805	n [rpm]
	2D/3D	0	0,04	0,10	0,13	0,10	P [kW]
	2D/3D	80	187	347	363	361	U _s [V]
	2D/3D	0,45	0,48	0,52	0,48	0,65	I _s [A]
63L/4 230/400V, 50 Hz Y circuit	2D/3D	0,71	1,26	1,26	1,26	0,74	M [Nm]
	2D/3D	0	438	1060	1428	1886	n [rpm]
	2D/3D	0	0,06	0,14	0,19	0,15	P [kW]
	2D/3D	65	185	352	361	360	U _s [V]
	2D/3D	0,50	0,61	0,66	0,71	0,80	I _s [A]
71S/4 230/400V, 50 Hz Y circuit	2D/3D	1,15	1,76	1,76	1,56	0,72	M [Nm]
	2D/3D	0	441	1059	1448	2469	n [rpm]
	2D/3D	0	0,08	0,20	0,24	0,19	P [kW]
	2D/3D	62	187	342	356	357	U _s [V]
	2D/3D	0,54	0,72	0,72	0,88	0,79	I _s [A]
71L/4 230/400V, 50 Hz Y circuit	2D/3D	1,81	2,55	2,57	2,38	1,22	M [Nm]
	2D/3D	0	461	1069	1481	2312	n [rpm]
	2D/3D	0	0,12	0,29	0,37	0,30	P [kW]
	2D/3D	57	181	329	344	343	U _s [V]
	2D/3D	0,83	1,02	1,04	1,24	1,30	I _s [A]

Legend

f_s Stator frequency	M Torque	M Torque	n Speed
[Hz] in Hertz	[Nm] in Newton metres	[%] in % of rated torque	[rpm] Speed in rpm



Motors with 50 Hz nominal point, Size 80S/4 to 132M/4 for Category 3D

Motor type		Legend												
		See below												
		Frequency inverter power and rated current												
		Motor power in [kW] at 50 Hz (upper value) and 100 Hz (lower value)												
			3	10	20	30	40	50	60	70	80	90	100	fs [Hz]
80S/4	0,55 kW	0,48	1,6	2,0	2,9	3,4	3,8	3,5	3,2	2,7	2,3	2,0	1,6	M [Nm]
	1,6 A		42	52	76	89	99	91	82	71	59	52	42	M [%]
		0,43	30	150	463	765	1,061	1,314	1,604	1,837	2,073	2,296	2,529	n [rpm]
80L/4	0,75 kW	0,67	2,1	3,1	4,0	4,7	5,2	4,7	4,4	3,8	3,2	2,8	2,3	M [Nm]
	2,2 A		40	60	77	90	100	90	85	73	62	54	45	M [%]
		0,63	26	166	471	769	1,091	1,377	1,614	1,864	2,108	2,348	2,564	n [rpm]
90S/4	1,1 kW	1,01	3,5	5,4	6,6	7,3	7,6	7,0	6,4	5,6	5,1	4,3	3,9	M [Nm]
	3,0 A		46	71	87	96	100	92	84	73	68	57	51	M [%]
		1,06	10	207	503	800	1,032	1,379	1,626	1,875	2,096	2,372	2,606	n [rpm]
90L/4	1,5 kW	1,31	4,3	5,8	7,8	9,0	9,5	9,0	8,3	7,2	6,5	5,6	4,9	M [Nm]
	3,7 A		42	56	76	87	92	87	80	70	63	54	47	M [%]
		1,37	0	196	495	790	1,091	1,388	1,654	1,909	2,173	2,437	2,695	n [rpm]
100L/4	2,2 kW	1,92	5,5	9,5	12,1	13,6	14,3	13,1	12,2	10,8	9,9	8,3	7,4	M [Nm]
	5,5 A		38	66	84	95	99	91	84	75	69	58	51	M [%]
		2,17	0	207	488	805	1,106	1,408	1,715	2,010	2,234	2,523	2,807	n [rpm]
100LA/4 T140°C	3 kW	2,61	10,7	13,6	16,4	18,0	18,9	17,7	15,6	13,2	11,4	10,0	8,3	M [Nm]
	7,0 A		53	67	81	89	93	87	77	65	56	49	41	M [%]
		2,39	12	256	541	833	1,140	1,410	1,681	1,940	2,233	2,490	2,760	n [rpm]
112M/4	4 kW	3,52	13,2	18,1	21,9	24,0	25,5	23,8	21,1	18,0	15,9	14,0	12,1	M [Nm]
	9,5 A		50	69	83	91	97	90	80	68	60	53	46	M [%]
		3,51	17	237	529	824	1,120	1,414	1,689	1,963	2,236	2,506	2,775	n [rpm]
132S/4	5,5 kW	5,04	22,0	25,8	30,0	34,0	36,2	33,7	29,6	25,5	21,9	18,4	16,1	M [Nm]
	12,5 A		61	71	83	94	100	93	82	71	60	51	45	M [%]
		4,78	44	240	536	832	1,130	1,428	1,714	1,995	2,276	2,556	2,834	n [rpm]
132M/4	7,5 kW	6,66	30,0	35,0	41,0	47,1	49,5	44,5	39,3	32,2	27,7	23,8	20,5	M [Nm]
	16,0 A		60	70	82	94	99	89	79	64	55	48	41	M [%]
		6,06	62	241	538	837	1,133	431	1,713	1,967	2,268	2,551	2,828	n [rpm]

Legend			
f_s	Stator frequency	M	Torque
[Hz]	in Hertz	[Nm]	in Newton metres
M	Torque	M	Torque
[%]	in % of rated torque	n	Speed
[rpm]	Speed in rpm		



Dust Explosion protection „ATEX“



Motors with 50 Hz nominal point, Size 80SH/4 to 180LH/4 for Category 2D and 3D

Dust explosion protection

Motor type / Circuit type	Category	3	20	40	60	100	f _s [Hz]
80SH/4 230/400V, 50 Hz Y circuit	2D/3D	2,64	3,74	3,73	3,71	1,83	M [Nm]
	2D/3D	14,8	516	1118	1628	2551	n [rpm]
	2D/3D	0	0,2	0,44	0,63	0,49	P [kW]
	2D/3D	38	174	328	368	352	U _s [V]
	2D/3D	1,11	1,4	1,41	1,61	1,75	I _s [A]
80LH/4 230/400V, 50 Hz Y circuit	2D/3D	3,33	4,92	5,08	4,84	2,51	M [Nm]
	2D/3D	10	508	1105	1596	2549	n [rpm]
	2D/3D	0	0,26	0,59	0,81	0,67	P [kW]
	2D/3D	36	172	333	363	363	U _s [V]
	2D/3D	1,38	1,77	1,81	2,13	2,22	I _s [A]
90SH/4 230/400V, 50 Hz Y circuit	2D/3D	0,97	5,52	6,83	5,72	3,11	M [Nm]
	2D/3D	76	540	1127	1676	2763	n [rpm]
	2D/3D	0,01	0,31	0,81	1	0,9	P [kW]
	2D/3D	29	168	332	361	362	U _s [V]
	2D/3D	1,29	2,06	2,36	2,43	2,49	I _s [A]
90LH/4 230/400V, 50 Hz Y circuit	2D/3D	5,99	9,75	10,22	10,07	5,43	M [Nm]
	2D/3D	33	521	1115	1605	2603	n [rpm]
	2D/3D	0,02	0,53	1,19	1,69	1,48	P [kW]
	2D/3D	35	173	338	361	361	U _s [V]
	2D/3D	2,38	3,28	3,33	4,19	4,31	I _s [A]
100LH/4 230/400V, 50 Hz Y circuit	2D/3D	2,38	14,6	14,79	12,08	6,96	M [Nm]
	2D/3D	80	545	1143	1704	2818	n [rpm]
	2D/3D	0,02	0,83	1,77	2,16	2,05	P [kW]
	2D/3D	27	171	334	360	361	U _s [V]
	2D/3D	2,8	4,84	4,82	4,89	4,9	I _s [A]
100AH/4 230/400V, 50 Hz Y circuit	2D/3D	9,8	19,31	20,19	18,21	10,14	M [Nm]
	2D/3D	49	528	1122	1646	2690	n [rpm]
	2D/3D	0,05	1,07	2,37	3,14	2,86	P [kW]
	2D/3D	32	172	336	363	363	U _s [V]
	2D/3D	4,17	6,15	6,41	7,08	7,36	I _s [A]
112MH/4 230/400V, 50 Hz Y circuit	2D/3D	16,56	24,27	26,49	21,76	11,92	M [Nm]
	2D/3D	47,4	543	1139	1683	2774	n [rpm]
	2D/3D	0,08	1,38	3,16	3,83	3,46	P [kW]
	2D/3D	33	170	338	349	349	U _s [V]
	2D/3D	5,78	7,63	8,31	9	9,2	I _s [A]



Motor type / Circuit type	Category	3	20	40	60	100	f _s [Hz]
132SH/4 230/400V, 50 Hz Y circuit	2D/3D	26,8	36	36	30,9	15,86	M [Nm]
	2D/3D	57	558	1158	1712	2827	n [rpm]
	2D/3D	0,16	2,11	4,37	5,53	4,7	P [kW]
	2D/3D	33	172	338	345	344	U _s [V]
	2D/3D	8,63	10,76	10,73	12,97	13,12	I _s [A]
132MH/4 230/400V, 50 Hz Y circuit	2D/3D	30,6	48,54	49,17	41,8	21,15	M [Nm]
	2D/3D	62	559	1158	1720	2845	n [rpm]
	2D/3D	0,2	2,84	5,96	7,53	6,3	P [kW]
	2D/3D	31	169	337	350	341	U _s [V]
	2D/3D	10,94	15	15,6	16,9	16,9	I _s [A]
132LH/4 230/400V, 50 Hz Y circuit	2D/3D	28,8	56,57	60,9	53,3	27,5	M [Nm]
	2D/3D	68	556	1151	1704	2830	n [rpm]
	2D/3D	0,21	3,29	7,34	9,5	8,15	P [kW]
	2D/3D	29	168	333	354	355	U _s [V]
	2D/3D	11,95	18,2	19,7	21	20,2	I _s [A]
160MH/4 230/400V, 50 Hz Y circuit	2D/3D	48,8	64,3	72	58,4	32,8	M [Nm]
	2D/3D	67	564	1159	1739	2885	n [rpm]
	2D/3D	0,34	3,8	8,75	10,6	9,9	P [kW]
	2D/3D	30	155	308	351	352	U _s [V]
	2D/3D	15,2	19,5	21,9	22,7	23,4	I _s [A]
160LH/4 230/400V, 50 Hz Y circuit	2D/3D	66,9	97,3	97,3	85,3	48	M [Nm]
	2D/3D	65	566	1167	1735	2875	n [rpm]
	2D/3D	0,46	5,78	11,9	15,5	14,5	P [kW]
	2D/3D	28	167	336	350	350	U _s [V]
	2D/3D	21,1	27,8	27,8	32,2	33,2	I _s [A]
180MH/4 230/400V, 50 Hz Y circuit	2D/3D	79,9	121	120	102	51,7	M [Nm]
	2D/3D	64	575	1176	1752	2908	n [rpm]
	2D/3D	0,54	7,3	14,7	18,8	15,7	P [kW]
	2D/3D	25	164	334	347	349	U _s [V]
	2D/3D	28,7	37,5	36,2	41,6	41,1	I _s [A]
180LH/4 230/400V, 50 Hz Y circuit	2D/3D	102	142	142	117	54,6	M [Nm]
	2D/3D	68	573	1173	1749	2926	n [rpm]
	2D/3D	0,73	8,54	17,5	21,6	16,7	P [kW]
	2D/3D	28	166	325	341	342	U _s [V]
	2D/3D	32,3	40,6	40,8	47	41	I _s [A]

Legend

f_s Stator frequency	M Torque	M Torque	n Speed
[Hz] in Hertz	[Nm] in Newton metres	[%] in % of rated torque	[rpm] Speed in rpm



Dust Explosion protection „ATEX“



Dust explosion protection

Motors 87 Hz nominal point Size 63 to 71 for category 2D and 3D

Motor type / Circuit type	Category	3	20	40	100	f _s [Hz]
63S/4 230/400V, 50 Hz Δ-circuit	2D/3D	0,65	0,86	0,86	0,86	M [Nm]
	2D/3D	0	450	1073	2741	n [rpm]
	2D/3D	0	0,04	0,1	0,25	P [kW]
	2D/3D	46	108	200	358	U _s [V]
	2D/3D	0,78	0,82	0,89	0,81	I _s [A]
63L/4 230/400V, 50 Hz Δ-circuit	2D/3D	0,71	1,26	1,26	1,26	M [Nm]
	2D/3D	0	438	1060	2719	n [rpm]
	2D/3D	0	0,06	0,14	0,36	P [kW]
	2D/3D	38	107	203	361	U _s [V]
	2D/3D	0,87	1,06	1,15	1,1	I _s [A]
71S/4 230/400V, 50 Hz Δ-circuit	2D/3D	1,15	1,76	1,76	1,88	M [Nm]
	2D/3D	0	441	1059	2661	n [rpm]
	2D/3D	0	0,08	0,2	0,52	P [kW]
	2D/3D	36	108	198	356	U _s [V]
	2D/3D	0,94	1,25	1,25	1,63	I _s [A]
71L/4 230/400V, 50 Hz Δ-circuit	2D/3D	1,81	2,55	2,57	2,56	M [Nm]
	2D/3D	0	461	1069	2770	n [rpm]
	2D/3D	0	0,12	0,29	0,74	P [kW]
	2D/3D	33	104	190	342	U _s [V]
	2D/3D	1,43	1,77	1,8	2,12	I _s [A]

Legend			
f_s Stator frequency	M Torque	M Torque	n Speed
[Hz] in Hertz	[Nm] in Newton metres	[%] in % of rated torque	[rpm] Speed in rpm



Motors with 87 Hz nominal point, Size 80S/4 to 132M/4 for Category 3D

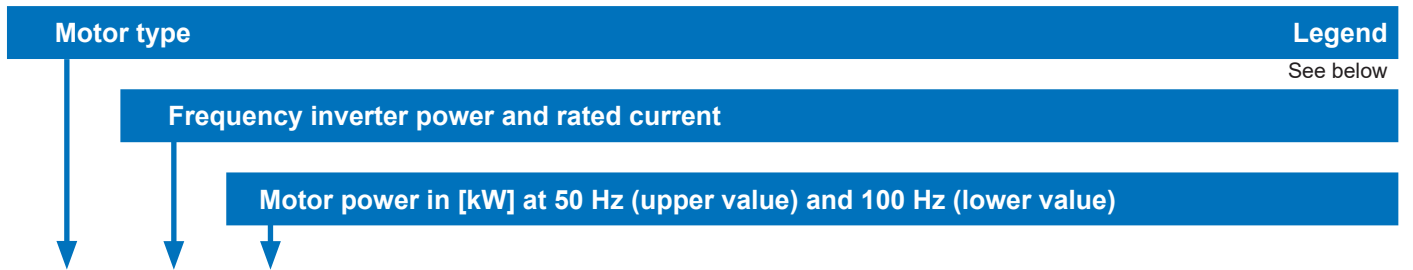

Motor type	Frequency inverter power [kW]	Rated current [A]	Motor power in [kW] at 50 Hz (upper value) and 100 Hz (lower value)											fs [Hz]
			3	10	20	30	40	50	60	70	80	90	100	
80S/4	1,1 kW	0,55	1,9	2,3	3,0	3,4	3,7	3,9	3,9	3,9	3,8	3,6	3,5	M [Nm]
	3,0 A	0,93	50	60	79	89	97	102	102	102	99	94	92	M [%]
		1,03	0	164	440	757	1,052	1,351	1,638	1,947	2,237	2,457	2,814	n [rpm]
80L/4	1,5 kW	0,78	2,9	3,3	4,2	4,7	5,0	5,4	5,6	5,7	5,5	5,3	5,0	M [Nm]
	3,7 A	1,36	56	63	81	90	96	104	108	110	106	102	95	M [%]
		1,46	0	207	493	792	1,086	1,377	1,668	1,970	2,256	2,439	2,813	n [rpm]
90S/4	2,2 kW	1,10	4,3	5,0	6,3	7,0	7,6	7,7	7,6	7,6	7,4	7,0	6,8	M [Nm]
	5,5 A	1,83	57	66	83	92	100	101	100	100	98	92	90	M [%]
		2,03	0	192	482	778	1,070	1,370	1,675	1,978	2,270	2,489	2,833	n [rpm]
90L/4	3 kW	1,39	4,1	5,4	7,3	8,5	9,3	9,6	9,9	9,9	9,8	9,1	8,6	M [Nm]
	7,0 A	2,38	40	52	71	83	90	93	96	96	95	88	83	M [%]
		2,56	73	179	487	789	1,085	1,387	1,684	1,988	2,284	2,497	2,863	n [rpm]
100L/4	4 kW	2,10	7,3	11,0	12,6	13,7	14,2	14,2	14,2	14,2	13,5	12,8	12,3	M [Nm]
	9,5 A	3,37	51	76	88	95	99	99	99	99	94	89	86	M [%]
		3,73	0	207	520	809	1,106	1,409	1,709	2,008	2,307	2,518	2,887	n [rpm]
100LA/4 T140°C	5,5 kW	2,98	11,3	14,1	17,2	18,6	19,6	19,8	20,2	20,0	18,8	18,0	17,6	M [Nm]
	12,5 A	4,72	56	69	85	92	96	97	99	98	93	89	86	M [%]
		5,27	7	229	524	819	1,116	1,413	1,713	2,014	2,304	2,505	2,869	n [rpm]
112M/4	7,5 kW	4,01	12,4	18,6	22,6	24,7	26,2	26,9	26,9	26,0	25,1	23,8	22,4	M [Nm]
	16,0 A	6,50	47	71	86	94	99	102	102	98	95	90	85	M [%]
		6,79	34	244	535	830	1,126	1,425	1,725	2,024	2,325	2,609	2,890	n [rpm]
132S/4	11 kW	5,75	20,7	25,9	31,0	34,9	36,7	38,2	38,5	38,3	36,8	34,3	29,7	M [Nm]
	24,0 A	9,14	57	71	86	96	101	105	106	106	102	95	82	M [%]
		9,06	49	241	541	839	1,139	1,437	1,737	2,037	2,335	2,544	2,918	n [rpm]
132M/4	15 kW	7,55	20,0	31,0	40,0	45,0	47,7	50,3	50,5	50,0	48,9	45,5	39,0	M [Nm]
	31,0 A	12,1	40	62	80	90	95	101	101	100	98	91	78	M [%]
		11,91	18	244	541	837	1,137	1,434	1,734	2,034	2,332	2,540	2,916	n [rpm]

Dust explosion protection

Legend			
fs	Stator frequency	M	Torque
[Hz]	in Hertz	[Nm]	in Newton metres
M	Torque	M	Torque
[%]	in % of rated torque	n	Speed
[rpm]	Speed in rpm		



Dust Explosion protection „ATEX“



Motors with 87 Hz nominal point, Size 80SH/4 to 180LH/4 for Category 2D and 3D

Motor type / Circuit type	Category	3	20	40	100	f _s [Hz]
80SH/4 230/400V, 50 Hz Δ-circuit	2D/3D	2,64	3,74	3,73	3,74	M [Nm]
	2D/3D	15	516	1118	2840	n [rpm]
	2D/3D	0	0,2	0,44	1,11	P [kW]
	2D/3D	22	100	190	355	U _s [V]
	2D/3D	1,92	2,42	2,44	2,77	I _s [A]
80LH/4 230/400V, 50 Hz Δ-circuit	2D/3D	3,33	4,92	5,08	5,1	M [Nm]
	2D/3D	10	508	1105	2803	n [rpm]
	2D/3D	0	0,26	0,59	1,5	P [kW]
	2D/3D	21	99	192	357	U _s [V]
	2D/3D	2,38	3,06	3,14	3,69	I _s [A]
90SH/4 230/400V, 50 Hz Δ-circuit	2D/3D	0,97	5,52	6,83	5,96	M [Nm]
	2D/3D	76	540	1127	2882	n [rpm]
	2D/3D	0,01	0,31	0,81	1,8	P [kW]
	2D/3D	17	97	192	358	U _s [V]
	2D/3D	2,24	3,57	4,08	4,25	I _s [A]
90LH/4 230/400V, 50 Hz Δ-circuit	2D/3D	6	9,75	10,2	10,1	M [Nm]
	2D/3D	33	521	1115	2822	n [rpm]
	2D/3D	0,02	0,53	1,19	2,98	P [kW]
	2D/3D	20	100	195	357	U _s [V]
	2D/3D	4,13	5,68	5,77	7,08	I _s [A]
100LH/4 230/400V, 50 Hz Δ-circuit	2D/3D	2,38	14,6	14,8	12,56	M [Nm]
	2D/3D	80	545	1143	2905	n [rpm]
	2D/3D	0,02	0,83	1,77	3,82	P [kW]
	2D/3D	16	99	193	359	U _s [V]
	2D/3D	4,85	8,39	8,35	8,5	I _s [A]
100AH/4 230/400V, 50 Hz Δ-circuit	2D/3D	9,8	19,3	20,2	20,2	M [Nm]
	2D/3D	49	528	1122	2840	n [rpm]
	2D/3D	0,05	1,07	2,37	6	P [kW]
	2D/3D	18	99	194	357	U _s [V]
	2D/3D	7,22	10,6	11,1	13	I _s [A]
112MH/4 230/400V, 50 Hz Δ-circuit	2D/3D	16,5	24,3	26,5	22,5	M [Nm]
	2D/3D	47	543	1139	2884	n [rpm]
	2D/3D	0,08	1,38	3,16	6,8	P [kW]
	2D/3D	19	98	195	341	U _s [V]
	2D/3D	10	13,2	14,4	15,8	I _s [A]

Dust explosion protection



Motor type / Circuit type	Category	3	20	40	100	f _s [Hz]
132SH/4 230/400V, 50 Hz Δ-circuit	2D/3D	26,8	36,1	36,1	31	M [Nm]
	2D/3D	57	558	1158	2915	n [rpm]
	2D/3D	0,16	2,11	4,37	9,46	P [kW]
	2D/3D	19	99	195	338	U _s [V]
	2D/3D	14,9	18,65	18,6	22,15	I _s [A]
132MH/4 230/400V, 50 Hz Δ-circuit	2D/3D	30,6	48,5	49,17	39,5	M [Nm]
	2D/3D	62	559	1158	2921	n [rpm]
	2D/3D	0,2	2,84	5,96	12,1	P [kW]
	2D/3D	18	98	195	332	U _s [V]
	2D/3D	18,95	26	27	28,4	I _s [A]
132LH/4 230/400V, 50 Hz Δ-circuit	2D/3D	28,8	56,6	60,9	48	M [Nm]
	2D/3D	68	556	1151	2927	n [rpm]
	2D/3D	0,21	3,29	7,34	14,7	P [kW]
	2D/3D	17	97	192	353	U _s [V]
	2D/3D	20,7	31,5	34,1	31,5	I _s [A]
160MH/4 230/400V, 50 Hz Δ-circuit	2D/3D	48,8	64,3	72,1	56,9	M [Nm]
	2D/3D	67	564	1159	2944	n [rpm]
	2D/3D	0,34	3,8	8,75	17,5	P [kW]
	2D/3D	17	89	178	348	U _s [V]
	2D/3D	26,4	33,9	37,9	37,2	I _s [A]
160LH/4 230/400V, 50 Hz Δ-circuit	2D/3D	66,9	97,4	97,4	82,4	M [Nm]
	2D/3D	65	566	1167	2939	n [rpm]
	2D/3D	0,46	5,78	11,9	25,4	P [kW]
	2D/3D	16	96	194	344	U _s [V]
	2D/3D	36,5	48,1	48,2	53,4	I _s [A]
180MH/4 230/400V, 50 Hz Δ-circuit	2D/3D	79,9	121	120	93,6	M [Nm]
	2D/3D	64	575	1176	2957	n [rpm]
	2D/3D	0,54	7,3	14,8	29	P [kW]
	2D/3D	14	95	193	343	U _s [V]
	2D/3D	49,8	65,1	62,7	65,8	I _s [A]
180LH/4 230/400V, 50 Hz Δ-circuit	2D/3D	102	14	142,8	96,8	M [Nm]
	2D/3D	68	573	1173	2963	n [rpm]
	2D/3D	0,73	8,54	17,5	30	P [kW]
	2D/3D	16	96	188	335	U _s [V]
	2D/3D	56	70,4	70,7	65,4	I _s [A]

Legend

f_s Stator frequency	M Torque	M Torque	n Speed
[Hz] in Hertz	[Nm] in Newton metres	[%] in % of rated torque	[rpm] Speed in rpm



Dust Explosion protection „ATEX“



Dust explosion protection

Motors 100 Hz nominal point Size 63 to 71 for category 2D and 3D

Motor type / Circuit type	Category	3	20	40	100	f _s [Hz]
63S/4 230/400V, 50 Hz Δ-circuit	2D/3D	0,55	0,61	0,61	0,6	M [Nm]
	2D/3D	0	500	1097	2835	n [rpm]
	2D/3D	0	0,03	0,07	0,18	P [kW]
	2D/3D	42	100	178	349	U _s [V]
	2D/3D	0,7	0,74	0,76	0,68	I _s [A]
63L/4 230/400V, 50 Hz Δ-circuit	2D/3D	0,56	0,83	0,83	0,83	M [Nm]
	2D/3D	0	488	1088	2844	n [rpm]
	2D/3D	0	0,04	0,09	0,25	P [kW]
	2D/3D	32	94	170	349	U _s [V]
	2D/3D	0,73	0,89	0,91	0,88	I _s [A]
71S/4 230/400V, 50 Hz Δ-circuit	2D/3D	0,92	1,22	1,22	1,22	M [Nm]
	2D/3D	0	474	1081	2832	n [rpm]
	2D/3D	0	0,06	0,14	0,36	P [kW]
	2D/3D	32	94	172	357	U _s [V]
	2D/3D	0,83	0,97	1,01	1,1	I _s [A]
71L/4 230/400V, 50 Hz Δ-circuit	2D/3D	1,53	1,82	1,81	1,81	M [Nm]
	2D/3D	0	479	1087	2830	n [rpm]
	2D/3D	0	0,09	0,21	0,54	P [kW]
	2D/3D	30	91	168	342	U _s [V]
	2D/3D	1,3	1,44	1,46	1,51	I _s [A]

Legend			
f_s Stator frequency	M Torque	M Torque	n Speed
[Hz] in Hertz	[Nm] in Newton metres	[%] in % of rated torque	[rpm] Speed in rpm



Motors with 100 Hz nominal point, Size 80S/4 to 132M/4 for Category 3D

Motor type			Legend											
			See below											
			Frequency inverter power and rated current											
			Motor power in [kW] at 50 Hz (upper value) and 100 Hz (lower value)											
			3	10	20	30	40	50	60	70	80	90	100	fs [Hz]
80S/4	0,75 kW	0,39	1,8	2,3	2,5	2,6	2,6	2,6	2,6	2,5	2,5	2,4	2,2	M [Nm]
	2,2 A		48	61	64	68	68	68	67	66	66	62	57	M [%]
		0,67	0	163	410	810	1,108	1,416	1,712	2,028	2,344	2,627	2,910	n [rpm]
80L/4	1,1 kW	0,53	3,0	3,3	3,6	3,6	3,6	3,6	3,6	3,6	3,5	3,4	3,2	M [Nm]
	3,0 A		58	63	69	69	69	69	69	69	67	66	62	M [%]
		0,99	0	196	505	812	1,116	1,414	1,715	2,015	2,313	2,611	2,908	n [rpm]
90S/4	1,5 kW	0,75	4,2	4,9	4,9	4,9	5,0	5,0	5,0	5,0	5,0	4,9	4,6	M [Nm]
	3,7 A		55	64	64	64	66	66	66	66	66	65	60	M [%]
		1,40	0	183	516	822	1,120	1,425	1,725	2,025	2,321	2,620	2,911	n [rpm]
90L/4	2,2 kW	1,06	4,0	5,6	7,2	7,2	7,2	7,2	7,2	7,2	7,1	6,9	6,6	M [Nm]
	5,5 A		39	54	70	70	70	70	70	70	69	67	64	M [%]
		2,00	20	192	484	799	1,098	1,406	1,707	2,008	2,309	2,606	2,905	n [rpm]
100L/4	3 kW	1,51	8,4	9,1	9,9	10,1	10,1	10,1	9,9	9,7	9,7	9,2	8,7	M [Nm]
	7,0 A		58	63	69	70	70	70	69	67	67	64	61	M [%]
		2,68	25	205	524	829	1,132	1,429	1,736	2,036	2,335	2,631	2,927	n [rpm]
100LA/4 T140°C	4 kW	1,99	6,6	11,3	13,1	13,2	13,2	13,2	13,2	13,3	13,3	12,6	12,0	M [Nm]
	9,5 A		32	56	64	65	65	65	65	65	66	62	59	M [%]
		3,69	20	200	530	834	1,130	1,442	1,734	2,028	2,332	2,639	2,944	n [rpm]
112M/4	5,5 kW	2,72	14,4	17,0	18,0	18,0	18,0	18,0	18,0	18,0	18,0	17,3	16,3	M [Nm]
	12,5 A		54	64	68	68	68	68	68	68	68	65	62	M [%]
		5,02	36	233	539	840	1,142	1,442	1,742	2,042	2,341	2,640	2,933	n [rpm]
132S/4	7,5 kW	3,63	20,6	22,0	24,3	24,3	24,3	24,3	24,3	24,3	24,3	24,3	24,3	M [Nm]
	16,0 A		57	61	67	67	67	67	67	67	67	67	67	M [%]
		7,42	36	227	530	828	1,124	1,425	1,724	2,023	2,324	2,623	2,918	n [rpm]
132M/4	11 kW	5,32	17,2	28,9	35,7	35,7	35,7	35,7	35,7	35,7	35,7	35,7	35,7	M [Nm]
	24,0 A		34	58	71	71	71	71	71	71	71	71	71	M [%]
		10,9	16	233	530	826	1,125	1,423	1,723	2,022	2,321	2,625	2,916	n [rpm]

Dust explosion protection

Legend			
fs	Stator frequency	M	Torque
[Hz]	in Hertz	[Nm]	in Newton metres
M	Torque	M	Torque
[%]	in % of rated torque	[rpm]	Speed in rpm



Dust Explosion protection „ATEX“



Motors with 100 Hz nominal point, Size 80SH/4 to 180LH/4 for Category 2D and 3D

Motor type / Circuit type	Category	3	20	40	100	f _s [Hz]
80SH/4 230/400V, 50 Hz Δ-circuit	2D/3D	1,99	2,45	2,45	2,46	M [Nm]
	2D/3D	29	534	1134	2913	n [rpm]
	2D/3D	0,01	0,14	0,29	0,75	P [kW]
	2D/3D	19	87	167	362	U _s [V]
	2D/3D	1,63	1,89	1,91	1,95	I _s [A]
80LH/4 230/400V, 50 Hz Δ-circuit	2D/3D	2,17	3,59	3,6	3,6	M [Nm]
	2D/3D	0	511	1115	2886	n [rpm]
	2D/3D	0	0,19	0,42	1,09	P [kW]
	2D/3D	16	84	163	350	U _s [V]
	2D/3D	1,91	2,54	2,55	2,73	I _s [A]
90SH/4 230/400V, 50 Hz Δ-circuit	2D/3D	0,97	4,92	4,89	4,9	M [Nm]
	2D/3D	76	529	1131	2902	n [rpm]
	2D/3D	0,01	0,27	0,58	1,49	P [kW]
	2D/3D	17	85	164	343	U _s [V]
	2D/3D	2,24	3,39	3,39	3,78	I _s [A]
90LH/4 230/400V, 50 Hz Δ-circuit	2D/3D	4,3	7,21	7,17	7,14	M Nm]
	2D/3D	0	518	1120	2913	n [rpm]
	2D/3D	0	0,39	0,84	2,18	P [kW]
	2D/3D	16	84	164	347	U _s [V]
	2D/3D	3,7	4,74	4,94	5,25	I _s [A]
100LH/4 230/400V, 50 Hz Δ-circuit	2D/3D	2,38	9,71	9,65	9,67	M [Nm]
	2D/3D	80	551	1152	2934	n [rpm]
	2D/3D	0,02	0,56	1,16	2,97	P [kW]
	2D/3D	16	83	164	348	U _s [V]
	2D/3D	4,85	6,46	6,62	6,98	I _s [A]
100AH/4 230/400V, 50 Hz Δ-circuit	2D/3D	9,29	12,96	13,11	13	M [Nm]
	2D/3D	0	535	1136	2932	n [rpm]
	2D/3D	0	0,73	1,56	4	P [kW]
	2D/3D	20	84	164	347	U _s [V]
	2D/3D	7,54	8,47	8,7	9,37	I _s [A]
112MH/4 230/400V, 50 Hz Δ-circuit	2D/3D	16,56	17,85	17,85	17,8	M Nm]
	2D/3D	47	548	1147	2915	n [rpm]
	2D/3D	0,08	1,02	2,14	5,44	P [kW]
	2D/3D	19	89	173	345	U _s [V]
	2D/3D	10,01	9,53	9,46	12,35	I _s [A]

Dust explosion protection



Motor type / Circuit type	Category	3	20	40	100	f _s [Hz]
132SH/4 230/400V, 50 Hz Δ-circuit	2D/3D	24,3	24,2	24,2	24,2	M [Nm]
	2D/3D	51	563	1163	2939	n [rpm]
	2D/3D	0,13	1,43	2,95	7,45	P [kW]
	2D/3D	18	88	167	342	U _s [V]
	2D/3D	13,8	14,6	14,6	17,2	I _s [A]
132MH/4 230/400V, 50 Hz Δ-circuit	2D/3D	29,7	29,6	29,6	29,7	M [Nm]
	2D/3D	50	568	1167	2946	n [rpm]
	2D/3D	0,16	1,76	3,62	9,15	P [kW]
	2D/3D	16	84	166	335	U _s [V]
	2D/3D	18,2	17,4	16,95	20,1	I _s [A]
132LH/4 230/400V, 50 Hz Δ-circuit	2D/3D	28,81	35,4	35,5	35,3	M [Nm]
	2D/3D	68	564	1163	2947	n [rpm]
	2D/3D	0,21	2,09	4,32	10,9	P [kW]
	2D/3D	17	84	164	340	U _s [V]
	2D/3D	20,7	22,1	21,6	21,4	I _s [A]
160MH/4 230/400V, 50 Hz Δ-circuit	2D/3D	48,4	48,4	48,3	48,2	M [Nm]
	2D/3D	58	564	1164	2954	n [rpm]
	2D/3D	0,29	2,86	5,88	14,9	P [kW]
	2D/3D	15	77	151	347	U _s [V]
	2D/3D	27,1	29,2	25,1	32,1	I _s [A]
160LH/4 230/400V, 50 Hz Δ-circuit	2D/3D	59,5	59,7	59,4	59	M [Nm]
	2D/3D	55	574	1173	2959	n [rpm]
	2D/3D	0,34	3,59	7,3	18,3	P [kW]
	2D/3D	14	82	163	346	U _s [V]
	2D/3D	35,5	32,9	31,9	37,3	I _s [A]
180MH/4 230/400V, 50 Hz Δ-circuit	2D/3D	70,7	70,5	69,8	70,8	M [Nm]
	2D/3D	69	582	1181	2969	n [rpm]
	2D/3D	0,51	4,29	8,63	22	P [kW]
	2D/3D	14	85	163	344	U _s [V]
	2D/3D	42,2	41,2	38,6	36	I _s [A]
180LH/4 230/400V, 50 Hz Δ-circuit	2D/3D	95,9	94,5	96,3	96,4	M [Nm]
	2D/3D	54	576	1176	2965	n [rpm]
	2D/3D	0,54	5,7	11,9	29,9	P [kW]
	2D/3D	15	82	162	337	U _s [V]
	2D/3D	65,5	53,6	54,6	65,7	I _s [A]

Legend

f_s Stator frequency	M Torque	M Torque	n Speed
[Hz] in Hertz	[Nm] in Newton metres	[%] in % of rated torque	[rpm] Speed in rpm



Dust Explosion protection „ATEX“

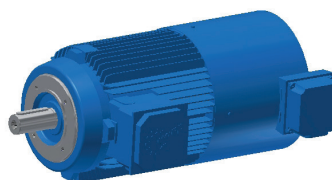

Motors with external fan, 50 Hz nominal point, Category 3D

Dust explosion protection

Motor type		Frequency inverter power and rated current												fs [Hz]
		Motor power in [kW] at 50 Hz (upper value) and 100 Hz (lower value)												
			3	10	20	30	40	50	60	70	80	90	100	
63S/4	0,55 kW	0,11	0,8	0,8	0,8	0,8	0,8	0,8	0,8	0,8	0,7	0,6	0,4	M [Nm]
	1,6 A		94	94	94	94	94	94	92	90	82	66	50	M [%]
		0,09	10	150	375	690	1,010	1,320	1,381	1,441	1,641	1,840	1,932	n [rpm]
63L/4	0,55 kW	0,17	1,3	1,3	1,3	1,3	1,3	1,3	1,2	1,2	1,1	0,9	0,8	M [Nm]
	1,6 A		96	96	96	96	96	96	93	91	83	73	61	M [%]
		0,18	0	142	419	696	990	1,282	1,458	1,633	1,787	1,941	2,151	n [rpm]
71S/4	0,55 kW	0,23	1,7	1,7	1,7	1,7	1,7	1,6	1,5	1,4	1,2	1,1	0,9	M [Nm]
	1,6 A		100	100	100	100	100	92	87	81	72	61	53	M [%]
		0,23	10	150	437	733	1,032	1,364	1,537	1,710	1,939	2,168	2,388	n [rpm]
71L/4	0,55 kW	0,33	2,4	2,4	2,4	2,4	2,4	2,4	2,2	1,9	1,6	1,4	1,3	M [Nm]
	1,6 A		92	92	92	92	92	92	83	73	62	55	48	M [%]
		0,33	0	128	427	734	1,042	1,339	1,594	1,843	2,092	2,326	2,490	n [rpm]
80S/4	0,55 kW	0,48	3,5	3,5	3,5	3,5	3,5	3,5	3,2	2,7	2,3	2,0	1,6	M [Nm]
	1,6 A		91	91	91	91	91	91	82	71	59	52	42	M [%]
		0,43	30	150	463	765	1,061	1,314	1,604	1,837	2,073	2,296	2,529	n [rpm]
80L/4	0,75 kW	0,67	4,7	4,7	4,7	4,7	4,7	4,7	4,4	3,8	3,2	2,8	2,3	M [Nm]
	2,2 A		90	90	90	90	90	90	85	73	62	54	45	M [%]
		0,63	26	166	471	769	1,091	1,377	1,614	1,864	2,108	2,348	2,564	n [rpm]
90S/4	1,1 kW	1,01	7,0	7,0	7,0	7,0	7,0	7,0	6,4	5,6	5,1	4,3	3,9	M [Nm]
	3,0 A		92	92	92	92	92	92	84	73	68	57	51	M [%]
		1,06	10	207	503	800	1,032	1,379	1,626	1,875	2,096	2,372	2,606	n [rpm]
90L/4	1,5 kW	1,31	9,0	9,0	9,0	9,0	9,0	9,0	8,3	7,2	6,5	5,6	4,9	M [Nm]
	3,7 A		87	87	87	87	87	87	80	70	63	54	47	M [%]
		1,37	0	196	495	790	1,091	1,388	1,654	1,909	2,173	2,437	2,695	n [rpm]
100L/4	2,2 kW	1,92	13,1	13,1	13,1	13,1	13,1	13,1	12,2	10,8	9,9	8,3	7,4	M [Nm]
	5,5 A		91	91	91	91	91	91	84	75	69	58	51	M [%]
		2,17	0	207	488	805	1,106	1,408	1,715	2,010	2,234	2,523	2,807	n [rpm]
100LA/4 T140°C	3 kW	2,68	20,3	20,3	20,3	20,3	20,3	18,2	16,1	13,9	12,1	10,1	9,0	M [Nm]
	7,0 A		100	100	100	100	100	90	79	69	59	50	44	M [%]
		2,59	11	172	488	804	1,105	1,406	1,673	1,940	2,214	2,488	2,753	n [rpm]
112M/4	4 kW	3,57	26,4	26,4	26,4	26,4	26,4	24,0	21,2	18,6	16,0	13,8	12,1	M [Nm]
	9,5 A		100	100	100	100	100	91	80	70	61	52	46	M [%]
		3,53	2	224	402	827	1,123	1,418	1,691	1,967	2,242	2,519	2,793	n [rpm]
132S/4	5,5 kW	4,88	35,2	36,4	36,4	36,4	35,8	32,3	28,3	23,4	19,5	17,3	14,2	M [Nm]
	12,5 A		97	100	100	100	98	89	78	64	54	47	39	M [%]
		4,28	26	250	551	851	1,153	1,444	1,725	2,010	2,299	2,585	2,876	n [rpm]
132M/4	7,5 kW	6,83	47,0	49,6	49,6	49,6	49,6	45,2	38,6	31,3	27,1	23,1	20,0	M [Nm]
	16,0 A		95	100	100	100	100	91	78	63	55	47	40	M [%]
		6,03	27	249	551	851	1,151	1,442	1,727	2,011	2,302	2,585	2,875	n [rpm]
132MA/4 T140°C	11 kW	8,19	57,2	60,8	60,8	60,8	60,8	54,5	46,8	38,8	32,9	28,9	25,1	M [Nm]
	24,0 A		94	100	100	100	100	90	77	64	54	48	41	M [%]
		7,52	18	238	539	840	1,140	1,435	1,720	2,008	2,298	2,580	2,866	n [rpm]

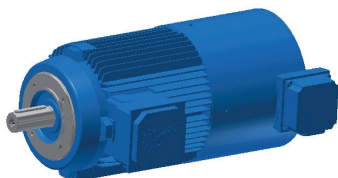

Motors with external fan, 87 Hz nominal point, Category 3D

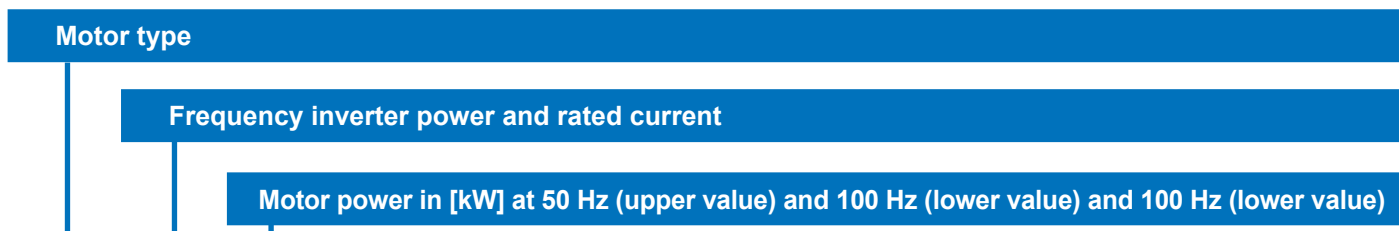

Motor type	Power [kW]	Current [A]	Frequency inverter power and rated current										fs [Hz]		
			3	10	20	30	40	50	60	70	80	90		100	
63S/4	0,55 kW	0,12	0,9	0,9	0,9	0,9	0,9	0,9	0,9	0,9	0,9	0,8	0,8	0,8	M [Nm]
	1,6 A	0,20	100	100	100	100	100	100	100	100	100	96	92	90	M [%]
		0,22	20	152	369	688	1,007	1,310	1,612	1,914	2,213	2,419	2,763		n [rpm]
63L/4	0,55 kW	0,18	1,3	1,3	1,3	1,3	1,3	1,3	1,3	1,3	1,3	1,3	1,2	1,2	M [Nm]
	1,6 A	0,30	100	100	100	100	100	100	100	100	100	96	92	90	M [%]
		0,33	20	175	407	715	1,002	1,306	1,610	1,909	2,207	2,415	2,713		n [rpm]
71S/4	0,55 kW	0,25	1,7	1,7	1,7	1,7	1,7	1,7	1,7	1,7	1,7	1,7	1,6	1,6	M [Nm]
	1,6 A	0,41	100	100	100	100	100	100	100	100	100	97	92	92	M [%]
		0,47	100	146	442	734	1,031	1,364	1,663	1,962	2,260	2,460	2,818		n [rpm]
71L/4	0,75 kW	0,35	2,5	2,5	2,5	2,5	2,5	2,5	2,5	2,5	2,5	2,5	2,4	2,3	M [Nm]
	2,2 A	0,61	95	95	95	95	95	95	95	95	95	95	92	90	M [%]
		0,69	0	188	488	782	1,077	1,350	1,633	1,941	2,245	2,457	2,797		n [rpm]
80S/4	1,1 kW	0,54	3,8	3,8	3,8	3,8	3,8	3,8	3,8	3,8	3,8	3,6	3,5		M [Nm]
	3,0 A	0,93	99	99	99	99	99	99	99	99	99	94	92		M [%]
		1,03	0	164	440	757	1,052	1,351	1,638	1,947	2,237	2,457	2,814		n [rpm]
80L/4	1,5 kW	0,79	5,5	5,5	5,5	5,5	5,5	5,5	5,5	5,5	5,5	5,3	5,0		M [Nm]
	3,7 A	1,36	106	106	106	106	106	106	106	106	106	102	95		M [%]
		1,46	0	207	493	792	1,086	1,377	1,668	1,970	2,256	2,439	2,813		n [rpm]
90S/4	2,2 kW	1,07	7,4	7,4	7,4	7,4	7,4	7,4	7,4	7,4	7,4	7,0	6,8		M [Nm]
	5,5 A	1,83	98	98	98	98	98	98	98	98	98	92	90		M [%]
		2,03	0	192	482	778	1,070	1,370	1,675	1,978	2,270	2,489	2,833		n [rpm]
90L/4	3 kW	1,42	9,8	9,8	9,8	9,8	9,8	9,8	9,8	9,8	9,8	9,1	8,6		M [Nm]
	7,0 A	2,38	95	95	95	95	95	95	95	95	95	88	83		M [%]
		2,56	73	179	487	789	1,085	1,387	1,684	1,988	2,284	2,497	2,863		n [rpm]
100L/4	4 kW	1,99	13,5	13,5	13,5	13,5	13,5	13,5	13,5	13,5	13,5	12,8	12,3		M [Nm]
	9,5 A	3,37	94	94	94	94	94	94	94	94	94	89	86		M [%]
		3,73	0	207	520	809	1,106	1,409	1,709	2,008	2,307	2,518	2,887		n [rpm]
100LA/4 T140°C	5,5 kW	3,02	20,3	20,3	20,3	20,3	20,3	20,3	20,3	20,3	20,3	19,3	18,5	17,3	M [Nm]
	12,5 A	4,87	100	100	100	100	100	100	100	100	100	95	91	85	M [%]
		5,21	51	211	516	820	1,120	1,419	1,718	2,016	2,263	2,510	2,877		n [rpm]
112M/4	7,5 kW	3,92	21,1	26,4	26,4	26,4	26,4	26,4	26,4	26,4	26,4	26,3	26,1	21,6	M [Nm]
	16,0 A	6,87	80	100	100	100	100	100	100	100	100	100	99	82	M [%]
		6,54	15	213	518	820	1,119	1,419	1,719	2,016	2,312	2,517	2,896		n [rpm]
132S/4	11 kW	5,52	33,5	36,4	36,4	36,4	36,4	36,4	33,8	31,7	28,7	25,3	20,5		M [Nm]
	24,0 A	6,79	92	100	100	100	100	100	93	87	79	70	56		M [%]
		6,27	15	240	545	848	1,150	1,450	1,755	2,057	2,357	2,566	2,921		n [rpm]
132M/4	15 kW	7,40	46,9	49,6	49,6	49,6	49,6	48,7	47,0	45,3	41,6	39,0	33,8		M [Nm]
	31,0 A	10,47	95	100	100	100	100	98	95	91	84	79	68		M [%]
		10,43	19	244	547	849	1,151	1,452	1,757	2,054	2,356	2,562	2,944		n [rpm]
132MA/4 T140°C	18 kW	9,01	51,9	60,8	60,8	60,8	59,7	59,6	56,4	53,9	50,4	45,6	42,6		M [Nm]
	38,0 A	12,20	85	100	100	100	98	98	93	89	83	75	70		M [%]
		13,09	17	234	540	840	1,143	1,443	1,746	2,049	2,349	2,556	2,934		n [rpm]

Dust explosion protection



Dust Explosion protection „ATEX“

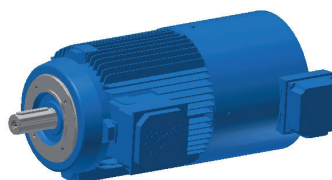

Motors with external fan, 100 Hz nominal point, Category 3D

Motor type

Frequency inverter power and rated current

Motor power in [kW] at 50 Hz (upper value) and 100 Hz (lower value)

Dust explosion protection

			3	10	20	30	40	50	60	70	80	90	100	fs [Hz]
63S/4	0,55 kW	0,09	0,6	0,6	0,6	0,6	0,6	0,6	0,6	0,6	0,6	0,6	0,6	M [Nm]
	1,6 A		71	71	71	71	71	71	71	71	71	71	70	M [%]
		0,18	6	134	401	731	1,033	1,346	1,652	1,947	2,253	2,542	2,827	n [rpm]
63L/4	0,55 kW	0,13	0,9	0,9	0,9	0,9	0,9	0,9	0,9	0,9	0,9	0,9	0,8	M [Nm]
	1,6 A		68	68	68	68	68	68	68	68	68	68	67	M [%]
		0,25	30	185	422	750	1,057	1,351	1,648	1,944	2,256	2,548	2,851	n [rpm]
71S/4	0,55 kW	0,18	1,2	1,2	1,2	1,2	1,2	1,2	1,2	1,2	1,2	1,2	1,1	M [Nm]
	1,6 A		71	71	71	71	71	71	71	71	71	69	65	M [%]
		0,34	30	181	462	774	1,076	1,389	1,687	1,985	2,284	2,583	2,884	n [rpm]
71L/4	0,55 kW	0,24	1,6	1,6	1,6	1,6	1,6	1,6	1,6	1,6	1,6	1,5	1,4	M [Nm]
	1,6 A		63	63	63	63	63	63	63	63	63	58	54	M [%]
		0,42	0	152	475	788	1,090	1,398	1,700	1,992	2,283	2,587	2,891	n [rpm]
80S/4	0,75 kW	0,38	2,5	2,5	2,5	2,5	2,5	2,5	2,5	2,5	2,5	2,4	2,2	M [Nm]
	2,2 A		66	66	66	66	66	66	66	66	66	62	57	M [%]
		0,67	0	163	410	810	1,108	1,416	1,712	2,028	2,344	2,627	2,910	n [rpm]
80L/4	1,1 kW	0,52	3,5	3,5	3,5	3,5	3,5	3,5	3,5	3,5	3,5	3,4	3,2	M [Nm]
	3,0 A		67	67	67	67	67	67	67	67	67	66	62	M [%]
		0,99	0	196	505	812	1,116	1,414	1,715	2,015	2,313	2,611	2,908	n [rpm]
90S/4	1,5 kW	0,75	5,0	5,0	5,0	5,0	5,0	5,0	5,0	5,0	5,0	4,9	4,6	M [Nm]
	3,7 A		66	66	66	66	66	66	66	66	66	65	60	M [%]
		1,40	0	183	516	822	1,120	1,425	1,725	2,025	2,321	2,620	2,911	n [rpm]
90L/4	2,2 kW	1,05	7,1	7,1	7,1	7,1	7,1	7,1	7,1	7,1	7,1	6,9	6,6	M [Nm]
	5,5 A		69	69	69	69	69	69	69	69	69	67	64	M [%]
		2,00	20	192	484	799	1,098	1,406	1,707	2,008	2,309	2,606	2,905	n [rpm]
100L/4	3 kW	1,45	9,7	9,7	9,7	9,7	9,7	9,7	9,7	9,7	9,7	9,2	8,7	M [Nm]
	7,0 A		67	67	67	67	67	67	67	67	67	64	61	M [%]
		2,68	25	205	524	829	1,132	1,429	1,736	2,036	2,335	2,631	2,927	n [rpm]
100LA/4 T140°C	4 kW	1,96	13,1	13,1	13,1	13,1	13,1	13,1	13,1	13,1	13,1	12,4	11,8	M [Nm]
	9,5 A		65	65	65	65	65	65	65	65	65	61	58	M [%]
		3,61	20	210	520	830	1,131	1,431	1,731	2,031	2,330	2,629	2,924	n [rpm]
112M/4	5,5 kW	2,67	18,0	18,0	18,0	18,0	18,0	18,0	18,0	18,0	18,0	18,0	18,0	M [Nm]
	12,5 A		68	68	68	68	68	68	68	68	68	68	68	M [%]
		5,46	5	220	520	820	1,120	1,420	1,720	2,020	2,320	2,599	2,898	n [rpm]
132S/4	7,5 kW	3,68	24,2	24,2	24,2	24,2	24,2	24,2	24,2	24,2	24,2	24,2	23,8	M [Nm]
	16,0 A		67	67	67	67	67	67	67	67	67	67	66	M [%]
		7,36	15	240	550	850	1,150	1,450	1,750	2,050	2,350	2,650	2,950	n [rpm]
132M/4	11 kW	5,42	35,7	35,7	35,7	35,7	35,7	35,7	35,7	35,7	35,7	35,7	33,9	M [Nm]
	24,0 A		72	72	72	72	72	72	72	72	72	72	68	M [%]
		10,46	15	240	550	850	1,150	1,450	1,750	2,050	2,350	2,650	2,950	n [rpm]
132MA/4 T140°C	15 kW	6,58	43,7	43,7	43,7	43,7	43,7	43,7	43,7	43,7	43,7	43,7	41,5	M [Nm]
	31,0 A		72	72	72	72	72	72	72	72	72	72	68	M [%]
		12,73	15	238	536	837	1,138	1,439	1,731	2,029	2,329	2,633	2,930	n [rpm]







Motor name plate at inverter operation

Motor of category 2D and efficiency IE2





Example

Name plates

50 Hz - characteristic curve

 Getriebebau NORD GmbH & Co. KG 22939 Bargteheide/GERMANY		 0102		 08513320				
DRIVESYSTEMS								
Type SK 90 LH/4 2D TF 2018								
3~ Mot. No. 200788472-100 12345678								
Th.Cl. 155(F) IP66 S1 EN 60034 (H), (A) / EN 60079								
Ex II 2D Ex tb IIIC T125°C Db BVS 04 ATEX E 037								
I N V E R T E R D U T Y	Hz	3	20	50	70	LINE	min ⁻¹	1415
	Nm	6,00	9,80	10,1	9,00		kW	1,5
	min ⁻¹	33	521	1390	1950		V	230/400 Δ/Y
	kW	0,02	0,53	1,47	1,83	OPERATION	Hz	50
	VΔ	35	174	361	361		A	5,8/3,35
	A	2,38	3,28	3,30	4,00		COS φ	0,79
							IE2	82,8 %
16,8 kg								
Versorgung durch Umrichter f _{max} 100 Hz f _{p min} 4 kHz PWM								
 www.nord.com								

87 Hz - characteristic curve

 Getriebebau NORD GmbH & Co. KG 22939 Bargteheide/GERMANY		 0102		 08513320				
DRIVESYSTEMS								
Type SK 90 LH/4 2D TF 2018								
3~ Mot. No. 200788472-100 12345678								
Th.Cl. 155(F) IP66 S1 EN 60034 (H), (A) / EN 60079								
Ex II 2D Ex tb IIIC T125°C Db BVS 04 ATEX E 037								
I N V E R T E R D U T Y	Hz	3	20	87	100	LINE	min ⁻¹	1415
	Nm	6,00	9,80	10,2	10,1		kW	1,5
	min ⁻¹	33	521	2425	2822		V	230/400 Δ/Y
	kW	0,02	0,53	2,60	2,98	OPERATION	Hz	50
	VΔ	20	100	361	361		A	5,8/3,35
	A	4,12	5,68	7,1	7,08		COS φ	0,79
							IE2	82,8 %
16,8 kg								
Versorgung durch Umrichter f _{max} 100 Hz f _{p min} 4 kHz PWM								
 www.nord.com								

Dust explosion protection

Name plates of other categories and efficiency classes may differ.

Attention



Permissible motor options for motors as per IEC Ex	
■ TF	Temperature sensor (Standard)
■ RD	Rain shield
■ WE	2nd shaft end
■ KB	Condensation hole
■ B3	Foot-mounted version





Motor options





Dust explosion protection

IEC Ex 2D

IEC Ex 3D

Type plates

				Getriebebau NORD GmbH & Co. KG 22939 Bargteheide / GERMANY IEC / EN 60034 / IEC 60079				08513650	
Type SK 90 LH/4 IDB TF									
3~ Mot.		No. 201688476-200							
Th.Cl. 155 (F)		IP 66		S1		Baujahr : 2018		(H)	
50 Hz		230/400 V		Hz		V			
5,8/3,34 A		1,5 kW		A		kW			
COSφ 0,79		1415 min ⁻¹		COSφ		min ⁻¹			
IE2-82,2%									
Ex tb IIIC T125°C Db					IECEx BVS 14.0022				
Kaltleiter fuer alleinigen Schutz PTC thermistors as sole protection									
									
www.nord.com									

				Getriebebau NORD GmbH & Co. KG 22939 Bargteheide / GERMANY IEC / EN 60034 / IEC 60079				08513650	
Type SK 90 LH/4 IDC TF									
3~ Mot.		No. 201688476-300							
Th.Cl. 155 (F)		IP55		S1		Baujahr : 2018		(H)	
50 Hz		230/400 V		Hz		V			
5,8/3,3 A		1,5 kW		A		kW			
COSφ 0,79		1415 min ⁻¹		COSφ		min ⁻¹			
IE2-82,2%									
Ex tc IIIB T125°C Dc					IEC Ex BVS 14.0022				
Kaltleiter fuer alleinigen Schutz PTC thermistors as sole protection									
									
www.nord.com									



Dust Explosion protection „HazLoc“



Dust explosion protection

Motors for the North American market

Class II, Division 2 Group, Groups F and G temperature code 165°C, operating mode S1, IP 55, IP 66, -20°C to +40°C

These are motors which are used in areas in which flammable mixtures of dust and oxygen do not occur under normal conditions, but in exceptional cases can not be ruled out.

These motors are available in efficiency classes High "IE2" and Premium "IE3". The motor data is listed for the voltages 230 / 460 V and 332 / 575 V which are especially important for the USA and Canada.

Mains operation

All motors are suitable for mains operation.

US motor data - dust

		1800 rpm 60 Hz			332/575 V 4 - pole						
Typ		P	P	n	U	f	M	I	cos φ	I _A /I _N	J
		[kW]	[hp]	[rpm]	[V]	[Hz]	[Nm]	[A]	[°]		[kgm ²]
63	S/4 TF IID2	0,12	0,16	1702	332/575	60	0,67	0,65/0,37	0,58	3,34	0,00021
63	L/4 TF IID2	0,18	0,25	1711	332/575	60	1,00	0,92/0,53	0,55	3,70	0,00028
71	S/4 TF IID2	0,25	0,33	1690	332/575	60	1,41	0,90/0,52	0,73	4,33	0,00072
71	L/4 TF IID2	0,37	0,50	1710	332/575	60	2,07	1,26/0,73	0,71	4,84	0,00086
80	S/4 TF IID2	0,55	0,75	1710	332/575	60	3,07	1,84/1,06	0,71	4,47	0,00109

and Inverter operation

✓	80	LP/4 TF IID2	0,75	1,00	1730	332/575	60	4,14	2,16/1,25	0,70	6,50	0,0019
✓	90	SP/4 TF IID2	1,10	1,50	1740	332/575	60	6,04	2,91/1,68	0,76	8,50	0,0034
✓	90	LP/4 TF IID2	1,50	2,00	1730	332/575	60	8,28	3,88/2,24	0,78	7,70	0,0039
✓	100	LP/4 TF IID2	2,20	3,00	1770	332/575	60	11,87	5,32/3,07	0,79	9,20	0,0081
✓	112	MP/4 TF IID2	3,70	5,00	1755	332/575	60	20,13	9,00/5,20	0,80	9,60	0,014
✓	132	SP/4 TF IID2	5,50	7,50	1770	332/575	60	29,68	13,5/7,81	0,77	10,20	0,032
✓	132	MP/4 TF IID2	7,50	10,0	1765	332/575	60	40,58	18,6/10,7	0,77	9,60	0,035
✓	160	MP/4 TF IID2	11,0	15,0	1770	332/575	60	59,35	24,7/14,2	0,84	8,80	0,067
✓	160	LP/4 TF IID2	15,0	20,0	1775	332/575	60	80,70	33,0/19,0	0,85	10,80	0,092
✓	180	MP/4 TF IID2	18,5	25,0	1780	332/575	60	99,00	24,2/14,0	0,82	10,10	0,160
✓	180	LP/4 TF IID2	22,0	30,0	1780	332/575	60	118,00	27,8/16,0	0,85	8,80	0,160

✓ these motors are also suitable for inverter operation



US motor data - dust

1800 rpm 60 Hz	230/460 V 4 - pole
---------------------------------	-------------------------------------

Typ	P	P	n	U	f	M	I	cos φ	I _A /I _N	J
	[kW]	[hp]	[rpm]	[V]	[Hz]	[Nm]	[A]	[°]		[kgm ²]
63 S/4 TF IID2	0,12	0.16	1687	230/460	60	0,68	0,94/0,47	0,54	3,21	0,00021
63 L/4 TF IID2	0,18	0.25	1706	230/460	60	1,01	1,18/0,59	0,57	3,58	0,00028
71 S/4 TF IID2	0,25	0.33	1710	230/460	60	1,40	1,56/0,78	0,64		0,00072
71 L/4 TF IID2	0,37	0.50	1715	230/460	60	2,06	1,89/0,94	0,69	4,84	0,00086
80 S/4 TF IID2	0,55	0.75	1710	230/460	60	3,07	2,70/1,35	0,71		0,00109

Mains operation

Dust explosion protection

80 LP/4 TF IID2	0,75	1.00	1730	230/460	60	4,14	3,14/1,57	0,70	6,50	0,0019	✓
90 SP/4 TF IID2	1,10	1.50	1740	230/460	60	6,04	4,20/2,10	0,76	8,40	0,0034	✓
90 LP/4 TF IID2	1,50	2.00	1730	230/460	60	8,28	5,60/2,80	0,78	7,60	0,0039	✓
100 LP/4 TF IID2	2,20	3.00	1770	230/460	60	11,87	7,68/3,07	0,79	9,20	0,0081	✓
112 MP/4 TF IID2	3,70	5.00	1755	230/460	60	20,13	13,0/6,50	0,80	9,50	0,014	✓
132 SP/4 TF IID2	5,50	7.50	1770	230/460	60	29,68	19,5/9,75	0,77	10,20	0,032	✓
132 MP/4 TF IID2	7,50	10.0	1765	230/460	60	40,58	26,7/13,4	0,77	9,60	0,035	✓
160 MP/4 TF IID2	11,0	15.0	1770	230/460	60	59,35	35,6/17,8	0,84	8,80	0,067	✓
160 LP/4 TF IID2	15,0	20.0	1775	230/460	60	80,70	47,6/23,8	0,85	10,80	0,092	✓
180 MP/4 TF IID2	18,5	25.0	1780	230/460	60	99,00	60,6/30,3	0,82	10,10	0,160	✓
180 LP/4 TF IID2	22,0	30.0	1780	230/460	60	118,00	69,6/34,8	0,85	8,80	0,160	✓

and Inverter operation

✓ these motors are also suitable for inverter operation

Permissible motor options for North American motors	
■ TF	Temperature sensor (Standard)
■ TW	Temperature sensor (bi-metal)
■ RD	Rain shield
■ RDD	Double fan cowl
■ WE	2nd shaft end
■ KB	Condensation hole
■ B3	Foot-mounted version
■ BRE	Brake

Motor options

Type SK 90 LP/4 CUS IID2 TF 2016											
3~Mot. No. 34714712 FIN 12345678											
INS F	NEMA	IP	55	S1	AMB 40 °C	TEFC	DP				
60Hz 230/460 VYY/Y EFF 84,0% CODE K											
5,60/ 2,80A		2 hp		1,5 kW		SF 1,15					
PF 0,78		1730 rpm		Class I DIV2 Group A, B, C, D							
Class II DIV2 Group F&G T3B-165°C											
Hz	rpm	Nm	lb-in	hp	A						
16,7 kg											
Over Temp Prot-2 Class F											
nord.com											

Type SK 90 LP/4 CUS IID2 BRE20 TF 2016											
3~Mot. No. 34714712 FIN 12345678											
INS F	NEMA	IP	55	S1	AMB 40 °C	TEFC	DP				
60Hz 230/460 VYY/Y EFF 84,0% CODE K											
5,60/ 2,80A		2 hp		1,5 kW		SF 1,15					
PF 0,78		1730 rpm		Class II DIV2 Group F&G T3B-165°C							
INVERTER DUTY VPWM CT											
Hz	rpm	Nm	lb-in	hp	A						
4	110	6,0	53,1	0,09	5/2,5						
83	2400	6,0	53,1	2	5/2,5						
16,7 kg		MB 20 Nm		230 VAC		205 VDC					
Over Temp Prot-2 Class F											
nord.com											

Type plates

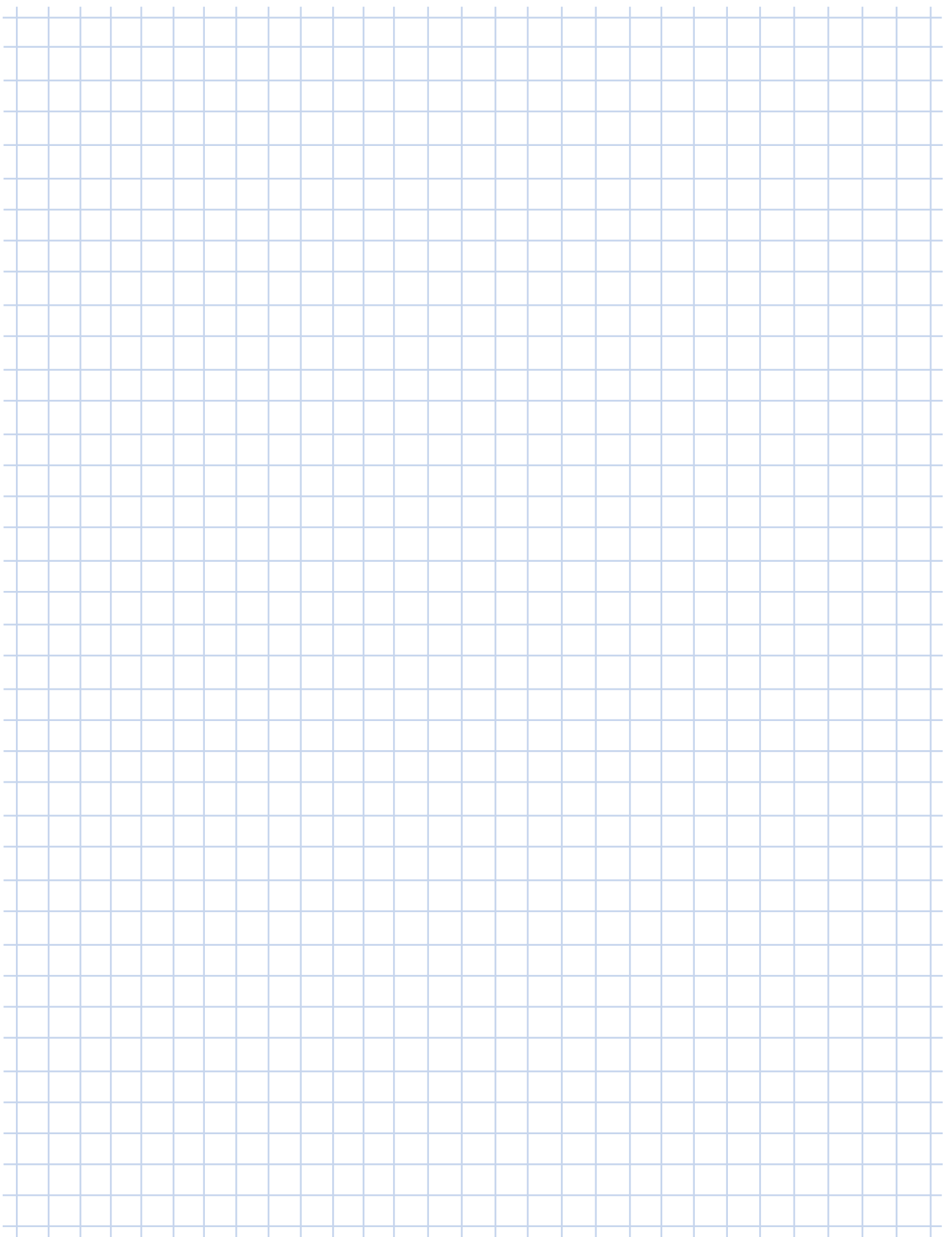



Basic information regarding European gas explosion protection

General

Explosive gas atmospheres occur in various areas of industry and crafts. They are usually caused by mixtures of oxygen in combination with explosive gases. Electrical and mechanical equipment for use in explosion hazard areas are subject to special national and international standards and guidelines.

Explosion protection prescribes rules which have the objective of protecting people and objects from possible explosion hazards.

Integrated explosion protection specifies that the measures for explosion protection must be carried out in a defined sequence:

- Rules of conduct to prevent the occurrence of explosive atmospheres
- Avoidance of ignition of explosive atmospheres
- Limiting the effect of an explosion to a manageable level

In the design of mechanical and electrical equipment the objective is to prevent ignition or to restrict its effects. For this, the explosion protection regulations come into effect.

The term ATEX, which is often used for explosion protection comes from the initial letters of an older French directive "Atmosphères Explosives".

Current European explosion protection regulations are based on Directive 2014/34/EU as the successor of the previously valid EU Directive 94/9/EC. This Directive serves for the harmonisation of statutory regulations of member states for devices and protective systems for proper use in explosion hazard areas.

This Directive is also referred to as the "Manufacturer's Directive" to distinguish it from the "1999/92 EC" directive, which also provides information on improvements to employee health and safety requirements in categories and zones.

Harmonised standards apply in order to meet basic safety and health requirements, some of which are exemplified below:

Standards for electrical devices:

- DIN EN 60079 - 0 General Regulations
- DIN EN 60079 - 1 Pressure-resistant Encapsulation "d"
- DIN EN 60079 - 7 Increased Safety "eb, ec"
- DIN EN 60079 - 15 Non Sparking "n"

Standards for mechanical devices:

- DIN EN ISO 80079-36:2016 Basics and requirements
- DIN EN ISO 80079-37:2016 Protection by Constructional Safety

Equipment group

Directive 2014/34 EU differentiates between two groups of devices:

- **Group I** devices - indicate equipment which is especially suitable for mining with device categories M1 and M2
- **Group II** devices - are suitable for use in other areas which may be endangered by an explosive atmosphere

For the majority of applications, the explosion protection data on the type plate begins with "II", therefore the special features of Group I systems will not be described in further detail here.

EU Directive

Gas explosion protection

Standards

- for electrical devices

- for mechanical devices

Device groups



Gas Explosion Protection „ATEX“

Standards - for motors

While Directive 2014/34 EU distinguishes between two categories of devices I and II, it is differentiated into Groups I, II and III based on EN 60079-0 standards for motors.

- **Group I** - features devices mining
- **Group II** . - features devices for gas explosion protection
- **Group III.** . - features devices for dust explosion protection

Zone

Zone

The categorisation into zones is made according to the conditions of the workplace – please refer to the statements in Directive 1999/92/EC with regard to the frequency of occurrence of the gas.

- Zone 0

Zone 0:

The area in which an explosive atmosphere consisting of a mixture of air and inflammable gases, vapours or aerosols is present permanently, for long periods, or frequently.

- Zone 1

Zone 1:

The area in which an explosive atmosphere consisting of air and inflammable gases, vapours or aerosols can occasionally form during normal operation.

- Zone 2

Zone 2:

The area in which an explosive atmosphere of air and combustible gases, vapours or aerosols normally does not occur, or only occurs for a short time during normal operation.

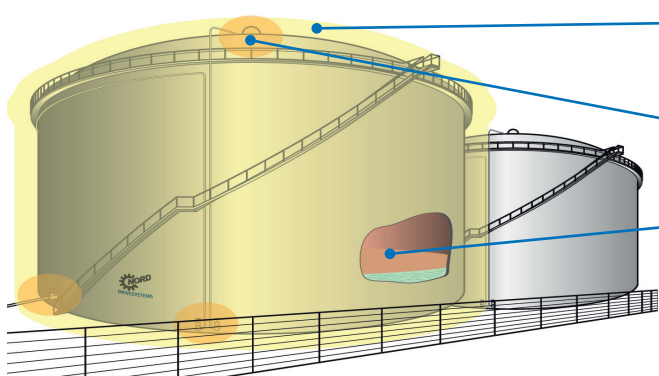

Zone 2:

Rare occurrence of explosive atmospheres

Zone 1:

Occasional occurrence of explosive atmospheres

Zone 0:

Constant or **frequent** occurrence of explosive atmospheres

Source: ATEX Poster

Temperature classes

Flammable atmospheres are divided into temperature classes, which provide information of how high the temperatures of surfaces may be that can come into contact with these gases.

For motors, this typically applies to externally accessible housing and shafts as well as for surfaces inside the motor and the terminal box.

T1 - T6

The temperature classes are divided into T1-T6, whereby in practice the temperature classes T3 and T4 deserve special attention because they are particularly often implemented by motors.

This means:

The higher the temperature class, the lower the maximum permissible surface temperature.

For example, motors of temperature class T4 have temperatures of up to 135 °C as a result of heating during operation, whereas motors in class T3 do not exceed 200 °C.



Type of ignition protection

Depending on the device category and type of risk, small letters in the explosion protection data identify the precise ignition protection type for a device. Encapsulations and constructional measures mainly come into question as methods of protection.

Different solutions are permissible and possible according to the hazard zone.

Gear units

As a rule, a gear unit becomes an Ex-protected system through a safe design, the use of Ex-specific special parts and detailed documentation.

The very informative EN 80079-37 indicates which requirements the technical components must meet.

Motors with pressure-resistant encapsulation "d" or pressure-resistant encapsulation with terminal boxes with Increased Safety "de"

The idea for protection with "Pressurised encapsulation - Ex d" consists of housing potential source of ignition in a pressure-resistant casing. The sealing surfaces are bounded by gaps which are resistant to ignition penetration. This safely prevents any explosion inside the housing from spreading to the environment.

For ignition protection class "Ex de" a terminal box with ignition protection type "Ex e" is used. The motor itself has ignition protection type "Ex d".

Pressurised encapsulation motors are assigned to Device Category 2G (Zone 1) and also meet the requirements for Device Category 3G (Zone 2). The rated power does not differ from that of the standard motor.

These motors are often used in cases where inverter operation, brakes, encoders and/or a very high level of safety are required. Typically, pressure resistant encapsulated motors supplied by NORD DRIVESYSTEMS fulfil the requirements for Explosion Group IIC and Temperature Class T4.

Motors versions Increased Safety, type "eb"

For motors of device categories 2G and 3G, i.e. Ex-Zones 1 and 2, sparking and impermissible temperatures are prevented as per ignition protection type "e" (Increased Safety). This is achieved by the design of the fans and fan cowls, bearings and terminal boxes.

Characteristic for this is e.g. the low surface resistance of plastic fans (depending on the circumferential speed of the fan). There are large air gaps between the rotating parts and large air gaps and leakage tracks in terminal boxes.

For the selection of the model it should be noted that drives units with ignition protection type "e" often have a reduced output power when compared to the corresponding standard motor.

These motors have different windings and have a larger air gap between the rotor and the stator in comparison with motors for non-explosive areas. This results in a genuine reduction in power. Ex e motors from NORD DRIVESYSTEMS comply with energy efficiency class IE2. "Ex e" motors are usually used up to Temperature Class T3.

Motor versions Non Sparking "Ex n"

For use in Zone 2, i.e. for category 3G devices, in addition to the motors described above with ignition protection classes "e" and "d" or "de", in particular motors with protection class "n" or with ignition protection class "E" with protection class Ex ec are suitable.

These simple, non-sparking motors are structurally similar to those with ignition protection class "eb" but do not achieve this level of protection. Non-sparking motors are usually used up to Temperature Class T3.

Areas of application

Explosion group IIC
Temperature class T4

Temperature class T3

Temperature class T3

ATEX LABELLING GAS FOR MOTORS



II 2G Exeb IIC T3 Gb

Labelling and categorisation of explosive environment					
Type of material	Frequency of occurrence of flammable material	Categorisation of explosive environment	Labelling of equipment		EPL - Equipment protection level
			Device group	Device category	
Gas (vapours, aerosols, etc.)	Constantly or frequently present	Zone 0	II		
	Occasionally present	Zone 1	II	1G	Ga
	Rarely present (short periods)	Zone 2	II	2G	Gb
				3G	Gc

Type of ignition protection for electrical devices				
Protection principle	Type of ignition protection	Identification	Use in zone	Standard
Pressure-resistant encapsulation	Contains any explosion within the motor housing	de or d	1 and 2	EN60079-1
Increased safety (EPL Gb)	Avoidance of high temperatures and sparks	eb	1 and 2	EN60079-7
Increased safety (EPL Gc)	Avoidance of high temperatures and sparks	ec	2	EN60079-7

Gas explosion protection

Explosion groups and temperature classes						
Explosion group Gas		Examples (not complete) for gases, depending on explosion group and temperature class				
IIA	IIB	IIC	Acetone, ethane, benzene, methane, propane	Ethyl alcohol, n-butane	Heating oil, petrol and diesel fuels	Acetaldehyde Ethyl ether
			Town gas (natural gas)	Ethylene	Hydrogen sulphide	
			Hydrogen	Acetylene		
			T1 <450 °C			
			T2 <300 °C			
			T3 <200 °C			
			T4 <135 °C			

ATEX LABELLING GAS FOR GEAR UNITS

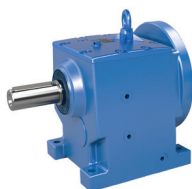

II 2G Exh IIC T3 Gb

Gas explosion protection

Labelling and categorisation of explosive environment					
Type of material	Frequency of occurrence of flammable material	Categorisation of explosive environment	Labelling of equipment		EPL - Equipment protection level
			Device group	Device category	
Gas (vapours, aerosols, etc.)	Constantly or frequently present	Zone 0	II	1G	Ga
	Occasionally present	Zone 1	II		
	Rarely present (short periods)	Zone 2	II		3G

Exh Labelling of mechanical devices comply with DIN EN ISO 80079-36

Drive dimensioning

Our customers' applications present a wide variety of requirements for ATEX-compliant operation. We are pleased to consider this in the design of the drive unit in order to contribute to the safe and reliable operation of plant and machinery.

Documentation of special requirements is made on the type plate of the gear unit - see Section "Explosion Protected Gear Units in General" or in the special documentation enclosed.

Explosion groups and temperature classes						
Explosion group		Gas				
		Examples (not complete) for gases, depending on explosion group and temperature class				
IIA	IIB	IIC	Acetone, ethane, benzene, methane, propane	Ethyl alcohol, n-butane	Heating oil, petrol and diesel fuels	Acetaldehyde, ethyl ether
			Town gas (natural gas)	Ethylene	Hydrogen sulphide	
			Hydrogen	Acetylene		
			T1 <450 °C			
		T2 <300 °C				
		T3 <200 °C				
		T4 <135 °C				





Exeb Motors Successor of the Exe Motors

Exec Motors Successor of the Exn Motors „Non Sparking“

NORD supplies modern Exeb and Exec motors from its own production, which comply with energy efficiency class IE2.

In many cases, due to their high efficiency and modern design, the commonly used reduction of the rated power is not necessary. These motors have type test certification from the PTB (Physikalisch-Technische Bundesanstalt).

PTB Certificates

NORD DRIVESYSTEMS explosion protected motors have the following type codes:

Type code

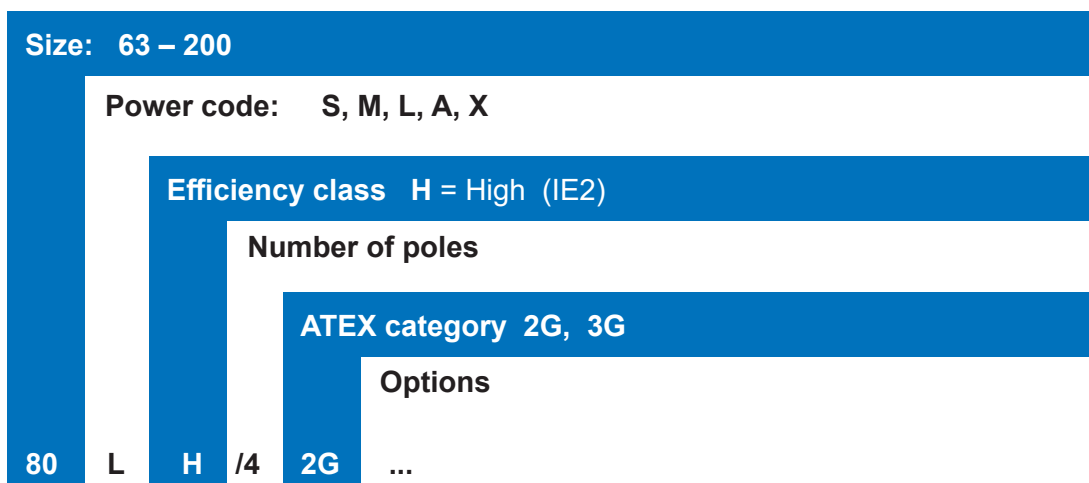

Gas explosion protection

The Exe and Exn motors listed comply with temperature classes T1, T2 and T2.

These motors may not be operated with frequency inverters.

Temperature classes

Notice
Not permitted for use with frequency inverters

Use of a suitable soft starter is permissible. The permissible ambient temperature or cooling air temperature for NORD Exe and Exn motors is between -20°C and +40°C.

These motors have the following features:

Features

- Housing material: Aluminium
- Protection class: IP55
- Insulation class: F
- Fan cowl material: Metal
- Fan material: Plastic; above Size 132 metal
- Type plate material: Stainless steel (V2A)
- Cable gland:

63, 71:	1 x M25x1.25 II brass
80, 90:	1 x M25x1.5 II brass
100, 112:	1 x M32x1.5 II brass
132:	1 x M32x1.5 II brass
160, 180:	1 x M40x1.5 II brass
- Blind plugs:

63, 71:	3 x M25x1.25 & 2 x M12x1.5 II brass
80, 90:	3 x M25x1.5 & 2 x M12x1.5 II brass
100, 112:	3 x M32x1.5 & 2 x M12x1.5 II brass
132:	3 x M32x1.5 & 2 x M12x1.5 & 2 x M16x1.5 II brass
160, 180:	1 x M40x1.5 & 2 x M12x1.5 & 2 x M16x1.5 II brass



Gas Explosion protection „ATEX“



Exeb Motors

II 2G Ex eb IIC T3 Gb

Type	P_N	n_N	M_N	I_N		$\cos \varphi$	η	M_A/M_N	M_K/M_N	I_A/I_N	J	kg	Time t_E	Time t_E
	[kW]	[rpm]	[Nm]	230/400 V	400/690 V		4/4x P_N [%]				[kgm ²]	* [kg]	T1/T2 [s]	T3 [s]
63 S /4 2G	0.12	1355	0.85	0.99/0.57		0.63	49.7	2.7	2.7	2.7	0.00021	3.6	60/60	50
63 L /4 2G	0.18	1370	1.25	1.49/0.86		0.54	55.4	2.5	2.6	3.0	0.00028	4.2	60/60	19
71 S /4 2G	0.25	1389	1.72	1.52/0.88		0.68	65.0	2.2	2.2	3.8	0.00072	5.4	29/29	25
71 L /4 2G	0.37	1397	2.53	2.25/1.30		0.63	67.5	2.0	2.4	4.3	0.00086	6.3	23/23	20
80SH/4 2G	0.55	1415	3.71	2.86/1.65		0.66	77.1	3.2	3.2	4.8	0.0014	8.0	45/45	40
80LH/4 2G	0.75	1400	5.12	3.55/2.05		0.68	79.6	3.0	3.1	4.9	0.0019	9.0	45/45	31
90SH/4 2G	1.10	1425	7.37	5.00/2.90		0.70	81.4	3.1	3.5	5.8	0.0034	12.0	24/24	21
90LH/4 2G	1.50	1425	10.0	7.53/4.35		0.65	83.6	3.3	3.5	5.6	0.0039	15.0	17/17	9
100LH/4 2G	2.20	1445	14.5	10.0/5.80	5.80/3.35	0.71	84.3	3.7	4.3	7.1	0.0075	21.0	18/18	13
100AH/4 2G	3.00	1450	19.8	12.6/7.30	7.30/4.21	0.76	85.5	2.4	3.6	6.5	0.0081	25.0	10/10	9
112MH/4 2G*	3.60	1445	23.8	13.9/8.00	8.00/4.64	0.77	86.2	3.4	4.0	8.3	0.014	28.0	14/14	6
132SH/4 2G	5.50	1460	36.0	20.8/12.0	12.0/6.93	0.77	87.7	3.1	3.5	7.7	0.032	42.0	14/14	9
132MH/4 2G*	7.50	1460	49.0	29.1/16.8	16.8/9.70	0.74	88.7	3.3	3.9	8.1	0.035	55.0	10/10	5
160MH/4 2G*	11.0	1470	71.5	39.0/22.5	22.5/13.0	0.82	89.8	2.9	3.4	8.6	0.067	93.0	12/12	5
160LH/4 2G	13.5	1470	87.7	45.9/26.5	26.5/15.3	0.85	90.4	3.32	3.85	9.53	0.092	122	14/14	6
180MH/4 2G*	15.0	1480	96.8		30.3/17.5	0.82	90.6	2.9	3.2	8.2	0.13	137	24/24	8
180LH/4 2G*	17.5	1478	113.1		34.5/19.9	0.84	91.0	2.9	3.2	8.2	0.16	155	23/23	7

* 112MH/4 2G, 132MH/4 2G, 160MH/4 2G, 180MH/4 2G and 180LH/4 2G cannot be operated with the integrated temperature sensor (TF) as the sole protection of the motor.

Exec Motors

II 3G Ex ec IIC T3 Gc

Type	P_N	n_N	M_N	I_N		$\cos \varphi$	η	M_A/M_N	M_K/M_N	I_A/I_N	J	kg	Time t_E	Time t_E
	[kW]	[rpm]	[Nm]	230/400 V	400/690 V		4/4x P_N [%]				[kgm ²]	* [kg]	T1/T2 [s]	T3 [s]
63 S /4 3G	0.12	1355	0.85	0.99/0.57		0.63	49.7	2.7	2.7	2.7	0.00021	3.6	60/60	50
63 L /4 3G	0.18	1370	1.25	1.49/0.86		0.54	55.4	2.5	2.6	3.0	0.00028	4.2	60/60	19
71 S /4 3G	0.25	1389	1.72	1.52/0.88		0.68	65.0	2.2	2.2	3.8	0.00072	5.4	29/29	25
71 L /4 3G	0.37	1397	2.53	2.25/1.30		0.63	67.5	2.0	2.4	4.3	0.00086	6.3	23/23	20
80SH/4 3G	0.55	1415	3.71	2.86/1.65		0.66	77.1	3.2	3.2	4.8	0.0014	8.0	45/45	40
80LH/4 3G	0.75	1400	5.12	3.55/2.05		0.68	79.6	3.0	3.1	4.9	0.0019	9.0	45/45	31
90SH/4 3G	1.10	1425	7.37	5.00/2.90		0.70	81.4	3.1	3.5	5.8	0.0034	12.0	24/24	21
90LH/4 3G	1.50	1425	10.0	7.53/4.35		0.65	83.6	3.3	3.5	5.6	0.0039	15.0	17/17	9
100LH/4 3G	2.20	1445	14.5	10.0/5.80	5.80/3.35	0.71	84.3	3.7	4.3	7.1	0.0075	21.0	18/18	13
100AH/4 3G	3.00	1450	19.8	12.6/7.30	7.30/4.21	0.76	85.5	2.4	3.6	6.5	0.0081	25.0	10/10	9
112MH/4 3G*	3.60	1445	23.8	13.9/8.00	8.00/4.64	0.77	86.2	3.4	4.0	8.3	0.014	28.0	14/14	6
132SH/4 3G	5.50	1460	36.0	20.8/12.0	12.0/6.93	0.77	87.7	3.1	3.5	7.7	0.032	42.0	14/14	9
132MH/4 3G*	7.50	1460	49.0	29.1/16.8	16.8/9.70	0.74	88.7	3.3	3.9	8.1	0.035	55.0	10/10	5
160MH/4 3G*	11.0	1470	71.5	39.0/22.5	22.5/13.0	0.82	89.8	2.9	3.4	8.6	0.067	93.0	12/12	5
160LH/4 3G	13.5	1470	87.7	45.9/26.5	26.5/15.3	0.85	90.4	3.32	3.85	9.53	0.092	122	14/14	6
180MH/4 3G*	15.0	1480	96.8		30.3/17.5	0.82	90.6	2.9	3.2	8.2	0.13	137	24/24	8
180LH/4 3G*	17.5	1478	113.1		34.5/19.9	0.84	91.0	2.9	3.2	8.2	0.16	155	23/23	7

* 112MH/4 3G, 132MH/4 3G, 160MH/4 3G, 180MH/4 3G and 180LH/4 3G cannot be operated with the integrated temperature sensor (TF) as the sole protection of the motor.

Gas explosion protection



Thermal protection of the machine by means of direct temperature monitoring of the windings with a thermistor temperature sensor is permitted, if this is certified and stated on the rating plate.

No sole protection
via temperature sensor

Getriebebau NORD GmbH & Co. KG 22939 Bargteheide / GERMANY 0102		08513450
Type SK 112MH/4 2G TF		2019
3 ~ Mot.	No. 200900815.200	12345678
TH.Cl. 155(F)	IP55 S1	EN 60034 (H), (A)/EN 60079
50 Hz	230/400 V Δ/Y	220-242/380-420 V Δ/Y
13,9/8,0 A	3,60 kW	PTB 14
cos φ 0,77	1445 min ⁻¹	ATEX 3038/01
IA/IN: 8,3 tE [s]: 14 14 6 230/400 V Δ/Y		
PTC nur als zusätzlicher Schutz zulässig		
www.nord.com		

Sole protection
via temperature sensor

Getriebebau NORD GmbH & Co. KG 22939 Bargteheide / GERMANY 0102		08513450
Type SK 80SH/4 2G TF		2019
3 ~ Mot.	No. 200900815.100	12345678
TH.Cl. 155(F)	IP55 S1	EN 60034 (H), (A)/EN 60079
50 Hz	230/400 V Δ/Y	220-242/380-420 V Δ/Y
2,86/1,65 A	0,55 kW	PTB 08
cos φ 0,66	1415 min ⁻¹	ATEX 3024/19
IA/IN: 4,3 tE [s]: 45 45 40 230/400 V Δ/Y		
TMS bei Angabe der t _A -Zeit nur mit PTC-Auslösegerät nach		
www.nord.com		

Notice!

If the time t_A is not indicated on the type plate, the thermistor is not permissible as the sole means of protection. It is essential that the motor is protected with a motor protection relay which has been approved by a testing facility. The motor protection relay must be approved for the ignition protection class which is stated on the motor.

Thermistor permissible as the sole protection

Notice
- if t_A is not stated on the type plate



Gas Explosion protection „ATEX“



Options

NORD DRIVESYSTEMS high efficiency explosion protected motors are available with the following options:

Motor Option	Designation
KB	Condensation hole (closed)
RD	Protective shield
TF	Thermistor (Standard)
WE	Second shaft end
IP66	Protection class IP66
SOSP	Special voltages between 104 - 725 V
60Hz	Motor for 60 Hz mains operation

Documentation

Documentation

The correct operating and installation instructions B1091 are included in every delivery and can be viewed in advance at www.nord.com.

They are available in the following languages:

- Available languages

German, English, French, Spanish, Italian, Serbian, Chinese, Arabic, Brazilian/Portuguese, Dutch, Bulgarian Slovenian, Danish, Greek, Lithuanian, Turkish, Latvian, Romanian, Polish, Russian Slovakian, Czech, Finnish, Swedish, Hungarian, Croatian and Norwegian.

- Siemens range

Exe and Exn motor, which are not stated in the above ranges, are taken from the Siemens product range. This is typical for powers > 17.5 kW, other pole numbers or motor speeds, as well as for Exn motors for inverter operation.

Gas explosion protection



Exd and Exde motors

No other explosion protected motors are offered on the market in a greater variety than pressure resistant encapsulated motors.

To make the advantages of this variety accessible to our customers, NORD DRIVESYSTEMS cooperates closely with various manufacturers. This enables us to provide our customers with an attractively priced and technically engaging drive, which realises the customer demand in the best possible way.

The standard version of these motors is as follows:

- II 2G T4 de IIC T4 Gb as 4-pole version - suitable for mains and inverter operation.

The majority overview of motors does not indicate individual motor features in this catalogue. The following overview presents the range of product and draws attention to special features.

- Power range: 0.12 - 200 kW (in combination with industrial gear units up to 1000 kW)
- Number of poles: 2,4,6 and 8 pole as well as switchable poles for 4-2, 6-4, 8-4 and 8-6 pole
- Cast iron motors in the entire power range and die cast aluminium motors up to 4 kW are possible
- Energy efficiency class IE1 as standard. IE2 and IE3 are possible at extra charge

Motor mounting on the gear unit is typically by means of IEC cylinders in use with IEC B5 standard motors for fast delivery.

In many cases, the motor can also be mounted directly on the gear unit. This has advantages in thermally critical cases or to achieve high output speeds and larger adjustment ranges with inverter operation. This version also has advantages for confined installation spaces.

Pressure resistant encapsulated motors are suitable for gas and dust applications in combination with very low ambient temperatures of $< -20^{\circ}\text{C}$ to -40°C .

High ambient temperatures of $>40^{\circ}\text{C}$ $< 60^{\circ}\text{C}$ are also possible. In some cases, this results in a reduction in motor power and / or ISO H insulation.

Further motor options which can be supplied on request:

- Efficiency class IE2 or IE3
- Exd version with pressure resistant terminal box encapsulation
- Protective or rain cover "RD"
- Foot-mounted version
- Temperature sensor for shut down in case of excess temperature "TF"
- Additional temperature sensors which switch at lower temperatures and are used as a warning. "2TF"
- PT100 for direct measurement of the winding temperature "PT100"
- ISO H
- Tropicalised installation
- External fan
- Special voltage "SOSP"
- IP66
- Standstill heating to prevent condensation "SH"
- Additional explosion protection for Zone 21 or Zone 22 "2D" / "3D"
- Brakes (various versions for combination with other options) as holding or working brakes "BRE"
- Incremental encoder "IG"
- Second shaft end, optionally with hand wheel "WE"
- Insulated bearings for inverter operation for motor sizes above Size 160

These special motors are marked accordingly with temperature specifications and are equipped with powerful standstill heaters.

Standard version

Motor mounting - IEC cylinder

Direct motor mounting - Advantages

Pressure resistant encapsulated motors $< -20^{\circ}\text{C}$ to -40°C

$>40^{\circ}\text{C}$ $< 60^{\circ}\text{C}$

Options on request



Gas Explosion protection „HazLoc“



Motors for the North American market

- Class I
- Division 2 Groups A, B, C, D
- Temperature Code 165°C
- Operating mode S1
- IP 55, IP 66,
- -20°C to +40°C

These are motors which are used in areas in which flammable mixtures of gases or vapours do not occur under normal conditions, but in exceptional cases cannot be ruled out.

These motors are available in efficiency classes High "IE2" and Premium "IE3". The motor data is listed for the voltages 230 / 460 V and 332 / 575 V which are particularly important for the USA and Canada ⇨ See type plate.

NORD DRIVESYSTEMS motors are suitable for mains operation. Inverter operation is in preparation.

Options

- Special voltages between 200 and 600 V
- Temperature sensor "TF"
- Temperature monitor "TW" bi-metal switch
- Protective cover "RD"
- Double fan cowl "RDD"
- Second shaft end "WE"

DRIVESYSTEMS											
Type SK 90 LP/4 CUS IID2 TF 2016											
3~Mot.			No. 34 714 712				FIN 12345678				
INS F	NEMA	IP	55	S1	AMB 40 °C	TEFC	DP				
60Hz	230/460 VYY/Y		EFF 84,0%		CODE K						
5,60/ 2,80A		2 hp		1,5 kW		SF 1,15					
PF 0,78		1730 rpm		Class I DIV2 Group A, B, C, D							
								Class II DIV2 Group F&G T3B-165°C			
Hz	rpm	Nm	lb-in	hp	A						
16,7 kg											
Over Temp Prot-2 Class F											

In addition to NORD's listed motors for the North American market, various motors from suppliers can be offered in addition. Please contact us.



Standard + High Efficiency 230/460 V 4-pole Class I Division 2

Type	P _N	P _N	n _N	Voltage	Frequency	M		cos φ	I _A /I _N	J
	[kW]	[hp]	[rpm]	[V]	[Hz]	[Nm]	[A]			[kgm ²]
63 S /4 TF ID2	0.12	0.16	1687	230/460	60	0.68	0.94/0.47	0.54	3.21	0.00021
63 L /4 TF ID2	0.18	0.25	1706	230/460	60	1.01	1.18/0.59	0.57	3.58	0.00028
71 S /4 TF ID2	0.25	0.33	1710	230/460	60	1.40	1.56/0.78	0.64		0.00072
71 L /4 TF ID2	0.37	0.50	1715	230/460	60	2.06	1.89/0.94	0.69	4.84	0.00086
80 S/4 TF ID2	0.55	0.75	1710	230/460	60	3.07	2.70/1.35	0.71		0.00109
80 L/4 TF ID2	0.75	1.00	1750	230/460	60	4.09	3.88/1.94	0.59	6.00	0.0019
90SH/4 TF ID2	1.10	1.50	1740	230/460	60	6.04	4.30/2.15	0.76	6.30	0.0034
90LH/4 TF ID2	1.50	2.00	1745	230/460	60	8.21	6.30/3.15	0.71	6.70	0.0039
100LH/4 TF ID2	2.20	3.00	1765	230/460	60	11.9	8.60/4.30	0.73	7.90	0.0075
112MH/4 TF ID2	3.60	5.00	1770	230/460	60	19.4	14.1/7.20	0.74	8.10	0.014
132SH/4 TF ID2	5.50	7.50	1770	230/460	60	29.7	20.9/10.5	0.78	8.20	0.032
132MH/4 TF ID2	7.50	10.0	1770	230/460	60	40.5	27.0/13.5	0.78	7.40	0.035

Premium Efficiency

80 LP/4 TF ID2	0.75	1.00	1730	230/460	60	4.14	3.14/1.57	0.70	6.50	0.0019
90SP/4 TF ID2	1.10	1.50	1740	230/460	60	6.04	4.20/2.10	0.76	8.40	0.0034
90LP/4 TF ID2	1.50	2.00	1730	230/460	60	8.28	5.60/2.80	0.78	7.60	0.0039
100LP/4 TF ID2	2.20	3.00	1770	230/460	60	11.9	7.68/3.07	0.79	9.20	0.0081
112MP/4 TF ID2	3.70	5.00	1755	230/460	60	20.1	13.0/6.50	0.80	9.50	0.014
132SP/4 TF ID2	5.50	7.50	1770	230/460	60	29.7	19.5/9.75	0.77	10.2	0.032
132MP/4 TF ID2	7.50	10.0	1765	230/460	60	40.6	26.7/13.4	0.77	9.60	0.035
160MP/4 TF ID2	11.0	15.0	1770	230/460	60	59.4	35.6/17.8	0.84	8.80	0.067
160LP/4 TF ID2	15.0	20.0	1775	230/460	60	80.7	47.6/23.8	0.85	10.8	0.092

Standard + High Efficiency 332/575 V 4-pole Class I Division 2

Type	P _N	P _N	n _N	Voltage	Frequency	M		cos φ	I _A /I _N	J
	[kW]	[hp]	[rpm]	[V]	[Hz]	[Nm]	[A]			[kgm ²]
63 S /4 TF ID2	0.12	0.16	1702	332/575	60	0.67	0.65/0.37	0.58	3.34	0.00028
63 L /4 TF ID2	0.18	0.25	1711	332/575	60	1.01	0.92/0.53	0.55	3.70	0.00028
71 S /4 TF ID2	0.25	0.33	1690	332/575	60	1.41	0.90/0.52	0.73	4.33	0.00072
71 L /4 TF ID2	0.37	0.50	1710	332/575	60	2.07	1.26/0.73	0.71	4.84	0.00086
80 S/4 TF ID2	0.55	0.75	1710	332/575	60	3.07	1.84/1.06	0.71	4.47	0.00109
80 L/4 TF ID2	0.75	1.00	1750	332/575	60	4.09	2.60/1.50	0.61	6.20	0.0019
90SH/4 TF ID2	1.10	1.50	1740	332/575	60	6.04	3.03/1.75	0.75	6.30	0.0034
90LH/4 TF ID2	1.50	2.00	1740	332/575	60	8.23	4.24/2.45	0.73	6.90	0.0039
100LH/4 TF ID2	2.20	3.00	1765	332/575	60	11.9	5.89/3.40	0.74	7.90	0.0075
112MH/4 TF ID2	3.60	5.00		332/575	60					
132SH/4 TF ID2	5.50	7.50	1780	332/575	60	29.5	14.4/8.30	0.74	8.20	0.032
132MH/4 TF ID2	7.50	10.0	1770	332/575	60	40.5	18.7/10.8	0.78	7.40	0.035

Premium Efficiency

80 LP/4 TF ID2	0.75	1.00	1730	332/575	60	4.14	2.16/1.25	0.70	6.50	0.0019
90SP/4 TF ID2	1.10	1.50	1740	332/575	60	6.04	2.91/1.68	0.76	8.50	0.0034
90LP/4 TF ID2	1.50	2.00	1730	332/575	60	8.28	3.88/2.24	0.78	7.70	0.0039
100LP/4 TF ID2	2.20	3.00	1770	332/575	60	11.9	5.32/3.07	0.79	9.20	0.0081
112MP/4 TF ID2	3.70	5.00	1755	332/575	60	20.1	9.00/5.20	0.80	9.60	0.014
132SP/4 TF ID2	5.50	7.50	1770	332/575	60	29.7	13.5/7.81	0.77	10.2	0.032
132MP/4 TF ID2	7.50	10.0	1765	332/575	60	40.6	18./10.7	0.77	9.60	0.035
160MP/4 TF ID2	11.0	15.0	1770	332/575	60	59.4	24.7/14.2	0.84	8.80	0.067
160LP/4 TF ID2	15.0	20.0	1775	332/575	60	80.7	33.0/19.0	0.85	10.8	0.092

Gas explosion protection

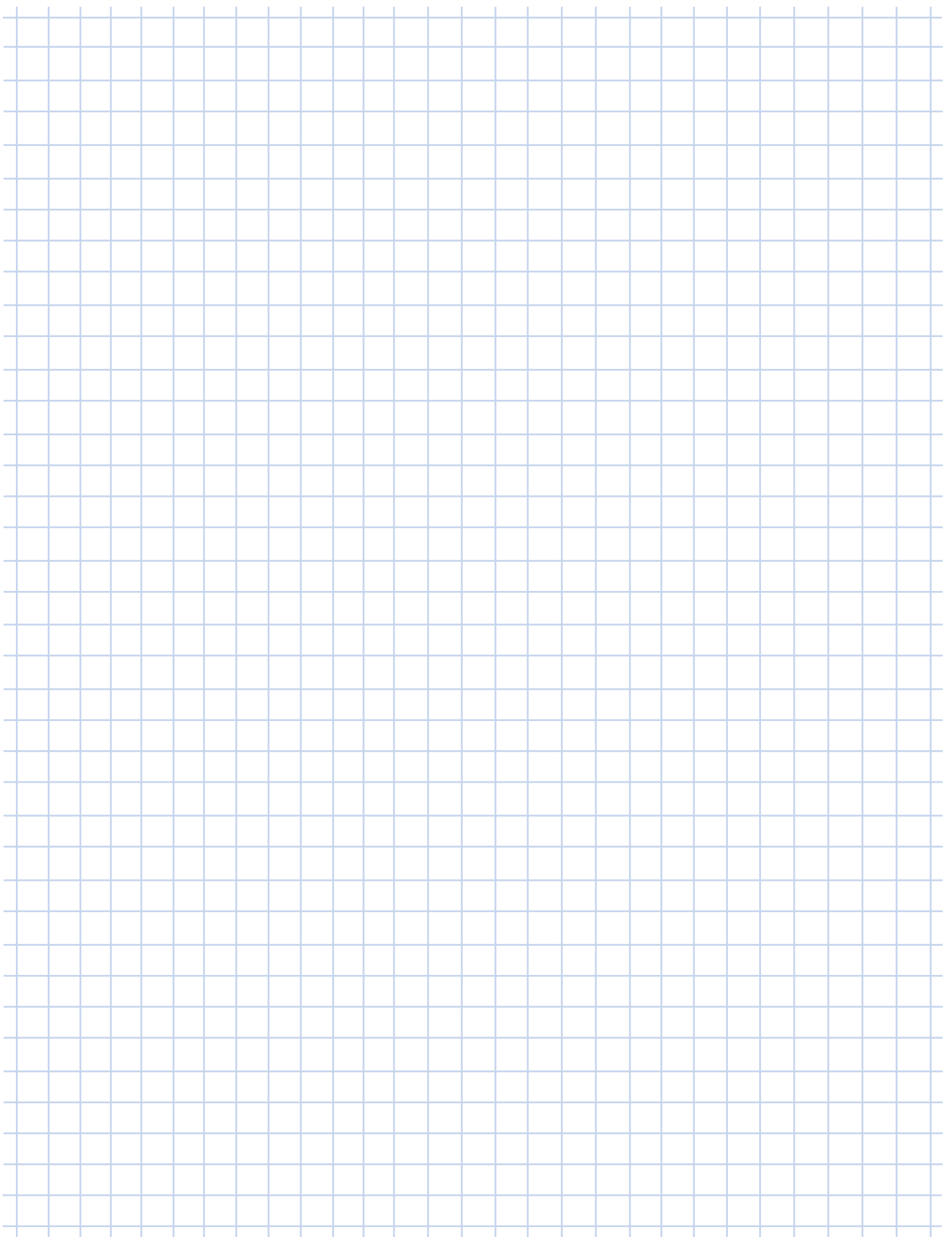

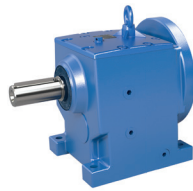

General

Unlike in much of the world, European strict requirements apply to non-electrical equipment such as e.g. Pumps or gearboxes to be used in potentially explosive atmospheres.

The basic requirements for these are defined in Directive 94/9/EC and its successor 2014/34/EU. To facilitate the demonstration that a device meets these requirements, uniform standards have been adopted at the European level, such as DIN EN ISO 80079-36:2016 and DIN EN ISO 80079-37:2016 were created, which apply in particular to the non-electrical area of explosion protection. These standards influence the conception, construction, testing, labelling and documentation of the devices and equipment. Compliance with these standards ensures that a product can be expected to comply with the essential conditions needed for the Declaration of Conformity.

The level of safety in each Member State is determined by these mandatory regulations for equipment and protective devices intended for use in explosion hazard areas. This facilitates free trade within the EU.

The safe operation of gearboxes and gearmotors depends on the standards-compliant design and two other aspects. Firstly, selection of a gearbox corresponding to the application, taking into account all the factors acting on the gearbox, and secondly proper assembly, operation and maintenance of a drive.

Selection of the gear unit should be made according to the technical explanations in the relevant product catalogues G1000, G1012, G1035 and G2000.

The gear unit selections described there must be complied with in order to avoid overloading the gear unit. This must be performed particularly conscientiously.

The selection of a suitable gear unit for the application, especially the necessary operating factor f_B for drive units to be operated in explosion hazard areas also has an influence on safety.

Special technical features of gear units

- Pressure venting to reduce the pressure inside the gear unit and to protect against dirt
- In case of a calculated oil temperature $> 84^{\circ}\text{C}$, automatic use of synthetic oil and Viton shaft sealing rings
- The strength of the housings, shafts and gears correspond to or exceed the minimum values required by the standards
- In some cases a special housing material may be required. This depends on the method of attachment and the weight of the motor
- In some cases, special coupling materials (electrically conducting)
- Largely closed covers for shrink disk versions
- Possibility of checking the oil level, even for small gear units



„ATEX“ Explosion protected gear units

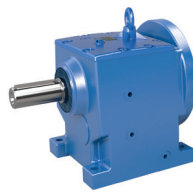

Available gear unit types

Helical gear units (Catalogue G1000)

	<ul style="list-style-type: none"> ✓ Foot or flange mounted ✓ UNICASE housing 	
	Sizes	11
	kW	0.12 – 160
	Nm	10 – 26,000
	i	1.35:1 – 14,340.31:1

Parallel shaft gear units (Catalogue G1000)

	<ul style="list-style-type: none"> ✓ Push-on, foot or flange mounted versions ✓ Hollow or solid shaft ✓ Compact design ✓ UNICASE housing 	
	Sizes	15
	kW	0.12 – 200
	Nm	65 – 90,000
	i	4.03:1 – 6,616.79:1

Helical worm gear units (Catalogue G1000)

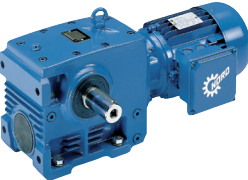
	<ul style="list-style-type: none"> ✓ Push-on, foot or flange mounted versions ✓ Hollow or solid shaft ✓ UNICASE housing 	
	Sizes	6
	kW	0.12 – 15
	Nm	46 – 3,090
	i	4.40:1 – 7,095.12:1

NORDBLOC.1 helical gear units (Catalogue G1000, G1012)

	<ul style="list-style-type: none"> ✓ Foot or flange mounted ✓ Die-cast aluminium housing (5 sizes) ✓ UNICASE housing ✓ Dimensions according to industrial standards 	
	Sizes	13
	kW	0.12 – 37
	Nm	55 – 3,300
	i	2.10:1 – 456.77:1

2-stage bevel gear units (Catalogue G1000, G1014)

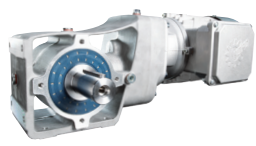
	<ul style="list-style-type: none"> ✓ Up to 97% efficiency ✓ Push-on, foot or flange mounted versions ✓ Hollow or solid shaft ✓ UNICASE housing ✓ Die-cast aluminium housing 	
	Sizes	5
	kW	0.12 – 9.2
	Nm	90 – 660
	i	3.55:1 – 70:1

3-stage bevel gear units (Catalogue G1000)

	<ul style="list-style-type: none"> ✓ Up to 95% efficiency ✓ Push-on, foot or flange mounted versions ✓ Hollow or solid shaft ✓ UNICASE housing 	
	Sizes	11
	kW	0.12 – 200
	Nm	180 – 50,000
	i	8.04:1 – 13,432.68:1

SMI worm gear units (Catalogue G1035)

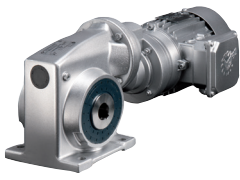
	<ul style="list-style-type: none"> ✓ Smooth surface ✓ Lifetime oil filling 	
	Sizes	4
	kW	0.12 – 1.5
	Nm	21 – 246
	i	5.00:1 – 540.0:1

SI worm gear units (Catalogue G1035)

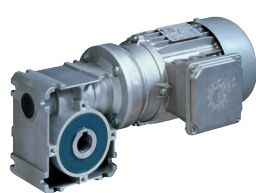
	<ul style="list-style-type: none"> ✓ Modular ✓ Universal fastening facilities ✓ IEC versions 	
	Sizes	5
	kW	0.12 – 4.0
	Nm	21 – 427
	i	5.00:1 – 3,000.00:1

Explosion protected gear units

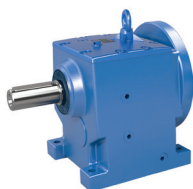

To enable selection according to the application, NORD recommends that the following enquiry form is used.



General enquiry form



Company: _____
 Customer number: _____
 Town/Postcode/Country: _____
 Contact: _____
 E-mail address: _____
 Phone: _____

Please send the enquiry directly to your local NORD contact.

See homepage:
www.nord.com
 (NORD → Sales)



Reference: _____
 Date: _____

	Helical gear units* G1000/G2000 <input type="radio"/>		Parallel shaft gear units* G1000 <input type="radio"/>		Bevel gear units* G1000 <input type="radio"/>		Worm gear units G1000/G1035 <input type="radio"/>
<input type="radio"/> Geared motors		<input type="radio"/> Adapter for IEC/NEMA motor/servo*		<input type="radio"/> Stand-alone motor (M7000)			
<input type="radio"/> W - Type (free drive shaft): External force: Axial F_{A1} : _____ [N] Radial F_{R1} : _____ [N]; Leverage on shaft collar: _____ [mm]							
<input type="radio"/> Type according to catalogue: _____				Pcs.: _____			

Parameters specific to the gear unit Delete section	Frequency inverter operation Delete section
Output speed n_2 at mains frequency: _____ [rpm]	<input type="radio"/> Control cabinet inverters <input type="radio"/> Motor-mounted inverter
Output torque M_2 : _____ [Nm]	Adjustment range from: _____ [Hz] to _____ [Hz]
Speed ratio i: _____	Speed from n_1 : _____ [rpm] to _____ [rpm]
Installation position (M1 – M6): _____	Constant torque within adjustment range: _____ [Nm]
Flange: <input type="radio"/> B14 <input type="radio"/> B5 \varnothing _____ [mm]	Characteristic curve: <input type="radio"/> 50 Hz <input type="radio"/> 70 Hz <input type="radio"/> 87 Hz <input type="radio"/> 100 Hz
<input type="radio"/> Hollow shaft <input type="radio"/> Solid shaft \varnothing _____ x _____ [mm]	Rotary encoder*: <input type="radio"/> Incremental <input type="radio"/> Absolute
Operating factor f_B : _____	Generating mode: Recovered Power _____ [kW]
Required min. bearing life according to L10h: _____ [h]	Outline conditions Delete section
Forces on output: Axial F_{A2} : _____ [N]	Ambient temperature: min. _____ to max. _____ [°C]
Radial F_{R2} : _____ [N] Leverage on shaft collar: _____ [mm]	Max. relative humidity RH: _____ [%]
Bearings: <input checked="" type="radio"/> normal <input type="radio"/> VL <input type="radio"/> VL2 <input type="radio"/> VL3 <input type="radio"/> AL	Max. installation altitude (if > 1,000 m): _____ [m]
Bevel gear and worm gear units: A/B side for flange/shaft*	<input type="checkbox"/> Internal <input type="checkbox"/> External <input type="checkbox"/> Contact with water* <input type="checkbox"/> Exposure to direct sunlight
Oil type: <input checked="" type="radio"/> Mineral <input type="radio"/> Synth. <input type="radio"/> Food grade <input type="radio"/> Bio-degradable	Other (dust/dirt/aggressive media; mech./chem.)*
Special oil: _____	ATEX Delete section
Parameters specific to the motor Delete section	Gas explosion protection
Rated power P_1 : _____ [kW]	<input type="radio"/> Zone 1 Ex II 2G <input type="radio"/> Zone 21 Ex II 2D
Rated speed n_1 : _____ [rpm]	<input type="radio"/> Zone 2 Ex II 3G <input type="radio"/> Zone 22 Ex II 3D
<input type="checkbox"/> Temperature sensor (TF) <input type="checkbox"/> Bi-metal temperature monitor (TV)	<input type="radio"/> Ex e II T3 <input type="radio"/> Non-conducting dust
Mains voltage: _____ [V] Mains frequency: _____ [Hz]	<input type="radio"/> EEx de IIC T4 <input type="radio"/> Conducting dust
Efficiency class: <input type="radio"/> IE1 <input type="radio"/> IE2 <input checked="" type="radio"/> IE3 <input type="radio"/> IE4	Painting/ Surface treatment Delete section
Protection class: <input checked="" type="radio"/> IP55 (Standard) <input type="radio"/> IP _____	<input type="radio"/> Without <input type="radio"/> 1.0 <input checked="" type="radio"/> 2.0 (Standard) <input type="radio"/> 3.0 <input type="radio"/> 3. _____
Operating mode: <input checked="" type="radio"/> S1 (Standard) <input type="radio"/> S _____*	<input type="radio"/> nsd tuPH (only for aluminium housings)
Switching frequency: _____ [cycles/h]	Colour (RAL): <input checked="" type="radio"/> Blue (5010) <input type="radio"/> Grey (7031)
Rel. switch-on time: _____ [%] <input type="checkbox"/> Back stop (RLS)	<input type="radio"/> Special colour (RAL No. / Colour): _____
Ventilation: <input checked="" type="radio"/> Standard <input type="radio"/> External (F) <input type="radio"/> Without (OL)	Remarks
Terminal box position: _____ Cable entry: _____	
Parameters specific to brake Delete section	
Braking torque M_B : _____ [Nm] <input type="checkbox"/> Manual release (HL)	
Brake/coil voltage: _____ [V]	
<input type="radio"/> Holding/emergency brake <input type="radio"/> Service brake	
Documentation operation and maintenance instruction (language abbreviation according to ISO 639-1):	
<input type="checkbox"/> DE <input type="checkbox"/> BG <input type="checkbox"/> ZH <input type="checkbox"/> CS <input type="checkbox"/> DA <input type="checkbox"/> ES <input type="checkbox"/> FI <input type="checkbox"/> FR <input type="checkbox"/> EN <input type="checkbox"/> EL <input type="checkbox"/> HU <input type="checkbox"/> IT <input type="checkbox"/> NL <input type="checkbox"/> NO <input type="checkbox"/> PL <input type="checkbox"/> PT <input type="checkbox"/> RU <input type="checkbox"/> SV <input type="checkbox"/> SK <input type="checkbox"/> LV <input type="checkbox"/> RO	

*Please add details in the remarks - Getriebebau NORD GmbH & Co. KG | Getriebebau-Nord-Str. 1 | D-22941 Bargteheide - DE-0818

Explosion protected gear units



„ATEX“ Explosion protected gear units

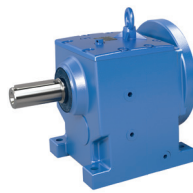

Details on the type plate

- Component strength

For the examination of a drive unit with regard to its suitability for use in explosion hazard areas, in particular the strength of the components as well as heating of the drive are examined individually with regard to the intended use. Many of these details are documented directly on the type plate.

In particular the following details have a direct influence on the strength of the components:

- Gear unit type, possible as the result of specification of the operating factor or the minimum bearing life
- Motor attachment directly or by means of an IEC or NEMA cylinder
- Output torque
- Gear ratio in combination with the motor torque
- Type and dimension of the output shaft
- Output shaft bearing type
- Forces and torques acting on the output shaft
- Braking torque

- Temperature calculation

These details are especially important for calculation of the drive temperature

- Gear unit type
- Motor attachment directly or by means of an IEC or NEMA cylinder
- Presence of a free input shaft (i.e. without attached motor)
- Speed of rotation of all rotating components
- Installation orientation - this has a great influence on the oil filling
- Bearing type
- Oil type
- Rated capacity
- Ventilation of the motor, whose cooling air flow also has an influence on the gear unit
- Inverter operation
- Maximum ambient temperature / cooling air temperature
- Installation altitude
- Number and type of seals

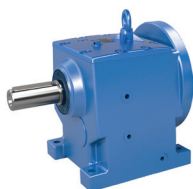

Many of the customer's details are documented directly on the type plate.

Ex Gear unit type plate

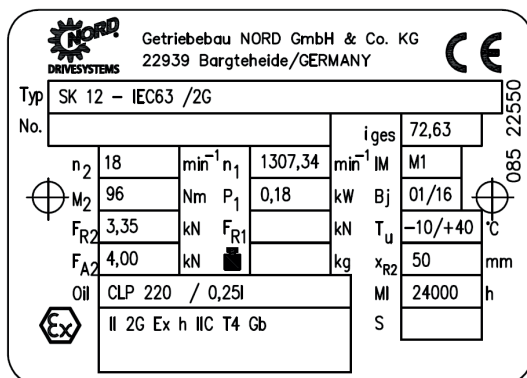

Explanation of the type plate			
Abbreviations	Unit	Designation	⇒ B2000 Section
Type	-	NORD gear unit type	
No.	-	Serial number	
iges	-	Overall gear unit ratio	
n ₂	rpm	Rated speed of gear unit output shaft*	
n ₁	rpm	Rated speed of the gear unit drive shaft or the drive motor*	
IM	-	Version (installation orientation)	6.1
M ₂	Nm	Max. permissible gear unit output shaft torque	
P ₁	kW	Max. permissible drive power or motor power	
B _j	-	Year of manufacture	
FR ₂	kN	Max. permissible transverse force on the gear unit output shaft	3.9
FR ₁	kN	Max. permissible transverse force on the gear unit drive shaft for option W	3.9
T _u	°C	Permissible ambient temperature for the gear unit	
FA ₂	kN	Max. permissible axial force on the gear unit output shaft	3.9
	kg	Total weight	3.8
MI	h	Interval for general overhaul of the gear unit in operating hours or according to the specification of the dimensionless maintenance class CM	5.2
xR ₂	mm	Max. dimension for the point of application of the transverse force FR ₂	3.9
Oil	-	Gear unit oil type (standard designation)	6.2
Last line		ATEX labelling, as per (DIN EN 13463-1): 1. Group (always II, not for mines) 2. Category (2G, 3G for gas or 2D, 3D for dust) 3. Ignition protection type if fitted (c) 4. Explosion group if applicable (IIC, IIB) 5. Temperature class (T1-T3 or T4 for gas) or max. surface temperature (e.g. 125 °C for dust) or special max. surface temperature see special documentation (TX) 6. Temperature measurement on commissioning (X)	4.3
S	-	Number of the special documentation, consisting of serial no. / year	
The maximum permissible speeds are 10 % above the rated speed, if the maximum permissible drive power P ₁ is not exceeded.			
If the fields FR ₁ , FR ₂ , FA ₁ and FA ₂ are empty, the forces are zero. If the field xR ₂ is empty, the point of application of force FR ₂ is central on the output shaft journal (⇒ Section 3.9")			

Explosion protected gear units



„ATEX“ Explosion protected gear units

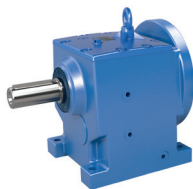

Details from the enquiry form

Examples

Forces on output: Axial F_{A2} : 500 [N]
 Radial F_{R2} : 1000 [N] Leverage on shaft collar: 120 [mm]

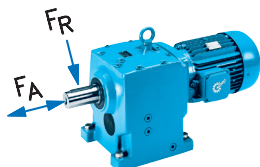

		Getriebebau NORD GmbH & Co. KG			
DRIVESYSTEMS		22939 Bargteheide / GERMANY			
Typ SK 12 VL /2D - 90 L/4 /2D					
No.				i_{ges}	8,56
n_2	162,7	min^{-1}	n_1	1390	min^{-1}
M_2	88,1	Nm	P_1	1,5	kW
F_{R2}	1	kN	F_{R1}		kN
F_{A2}	0,5	kN	F_{A1}		kN
Oil CLP 220				T_u	-10/+40 °C
				MI	7442 h
II 2D Ex h IIC T125°C Db				S	

Motor-specific parameters Delete section

Rated power P_1 :	4.6	[kW]
Rated speed n_1 :	1800	[rpm]
<input type="checkbox"/> Temperature sensor (TF)	<input type="checkbox"/> Bi-metal temperature monitor (TW)	
Mains voltage		[V]
Mains frequency	60	[Hz]

		Getriebebau NORD GmbH & Co. KG			
DRIVESYSTEMS		22939 Bargteheide / GERMANY			
Typ SK 32 - IEC112 /2D					
No.				i_{ges}	9,80
n_2	183,8	min^{-1}	n_1	1800	min^{-1}
M_2	239	Nm	P_1	4,6	kW
F_{R2}		kN	F_{R1}		kN
F_{A2}		kN	F_{A1}		kN
Oil CLP 220				T_u	-10/+40 °C
				MI	9555 h
II 2D Ex h IIC T125°C Db				S	

Frequency inverter operation Delete section

<input checked="" type="radio"/> Control cabinet inverter	<input type="radio"/> Motor-mounted inverter
Adjustment range from :	10 [Hz] to 80 [Hz]
Speed from n_1	[rpm] to [rpm]
Constant torque within adjustment range:	100 [Nm]
Characteristic curve :	<input checked="" type="radio"/> 50 Hz <input type="radio"/> 70 Hz <input type="radio"/> 87 Hz <input type="radio"/> 100 Hz

		Getriebebau NORD GmbH & Co. KG			
DRIVESYSTEMS		22939 Bargteheide / GERMANY			
Typ SK 32 - IEC112 /2D					
No.				i_{ges}	9,80
n_2	233,7	min^{-1}	n_1	2288	min^{-1}
M_2	262	Nm	P_1	4	kW
F_{R2}		kN	F_{R1}		kN
F_{A2}		kN	F_{A1}		kN
Oil CLP 220				T_u	-10/+40 °C
				MI	9172 h
II 2D Ex h IIC T125°C Db				S	

Framework conditions Delete section

Ambient temperature: min. -10 to max. +50 [°C]

		Getriebebau NORD GmbH & Co. KG			
DRIVESYSTEMS		22939 Bargteheide / GERMANY			
Typ SK 32 - IEC112 /2D					
No.				i_{ges}	9,80
n_2	146	min^{-1}	n_1	1430	min^{-1}
M_2	262	Nm	P_1	4	kW
F_{R2}		kN	F_{R1}		kN
F_{A2}		kN	F_{A1}		kN
Oil CLP 220				T_u	-10/+50 °C
				MI	9172 h
II 2D Ex h IIC T125°C Db				S	

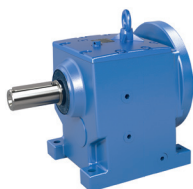

Preventative maintenance

Scheduled and proper maintenance of gear units is especially important for explosion protection as it has a direct impact on safe operation. In particular, operators of Category 2 (2D or 2G) drives for use in Zone 1 or 21 must take expected errors into account.

This includes scheduled replacement of the gear oil as well as regular checks on the oil level – refer to the details in the operating and maintenance manual B2000.

In addition, the bearings and shaft sealing rings must be replaced as a preventative measure depending on the requirements of drive selection and application. Maintenance in case of damage or signs of imminent bearing damage results in a potentially dangerous situation and must be avoided at all costs!

To enable this preventative maintenance, according to a draft version of DIN EN ISO 80079-37:2016, NORD labels its Category 2 gear units with a maintenance interval "MI". This interval indicates the number of operating hours after which replacement of the bearings and seals is advisable. In association with this, other components of the gear unit are subjected to a visual inspection and are replaced in rare cases.

The maintenance interval assumes use of the gear unit with the rated power / rated torque. Lower powers have a positive effect on the maintenance interval.

Example for a gear unit with a maintenance interval of 24497 hours.

Oil level check

Maintenance interval

Examples

		Getriebebau NORD GmbH & Co. KG 22939 Bargteheide / GERMANY			
Typ SK 22 /2G - 80 LH/4 /2G					
No. <input type="text"/>					
				i _{ges} 24,73	
n ₂	56,71	min ⁻¹	n ₁	1400	min ⁻¹
M ₂	126	Nm	P ₁	0,75	kW
F _{R2}	1	kN	F _{R1}		kN
F _{A2}	0,5	kN	F _{A1}		kN
Oil		CLP 220		T _u -10/+40 °C	
		II 2G Ex h IIC T3 Gb		x _{R2} <input type="text"/> mm	
				MI 24497 h	
				S <input type="text"/>	

Explosion protected gear units

On customer's request, it is also possible to specify a maintenance class, which enables the customer to calculate the maintenance interval depending in the period of use per day and the actual average output power. Further details can be found in the operation and maintenance manual B2000.

Maintenance class

		Getriebebau NORD GmbH & Co. KG 22939 Bargteheide / GERMANY			
Typ SK 22 /2G - 80 LH/4 /2G					
No. <input type="text"/>					
				i _{ges} 24,73	
n ₂	56,71	min ⁻¹	n ₁	1400	min ⁻¹
M ₂	126	Nm	P ₁	0,75	kW
F _{R2}		kN	F _{R1}		kN
F _{A2}		kN	F _{A1}		kN
Oil		CLP 220		T _u -10/+40 °C	
		II 2G Ex h IIC T3 Gb		x _{R2} <input type="text"/> mm	
				MI CM=3 h	
				S <input type="text"/>	



„ATEX“ Explosion protected gear units

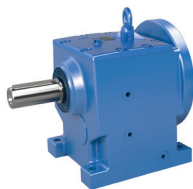

DECLARATION OF CONFORMITY

You can find certificates on the NORD homepage under www.nord.com - Heading DOCUMENTATION / CERTIFICATES



GETRIEBEBAU NORD
Member of the NORD DRIVESYSTEMS Group

Getriebebau NORD GmbH & Co. KG
Getriebebau-Nord-Str. 1, 22941 Bargteheide, Germany . Fon. +49(0)4532 289 - 0, Fax +49(0)4532 289 - 2253 . info@nord.com

EU-Konformitätserklärung
Im Sinne der EU-Richtlinie 2014/34/EU Anhang VIII

Hiermit erklärt Getriebebau NORD GmbH & Co. KG, Seite 1 von 1
dass die Getriebe und Getriebemotoren der Produktreihen

- **Stirnradgetriebe**
Typ SK ...
- **Schneckengetriebe**
Typ SK 02..., SK 1Sl..., St
SK 3..., SK 4....
- **Flachgetriebe**
Typ SK ...82, SK ...82.1,
SK ..82NB
- **Kegelradgetriebe**
Typ SK 9....

mit der ATEX-Kennzeichnung  II 2D / 2G

der folgenden Richtlinie entsprechen:
ATEX-Richtlinie für Produkte **2014/34/EU**
Angewandte Normen:

DIN EN 1127-1:
DIN EN ISO 80079-36:
DIN EN ISO 80079-37:
DIN EN 60079-0:

Getriebebau NORD hinterlegt die gemäß 2014/34/EU Anhang geforderten Unterlagen bei der benannten Stelle:

DEKRA EXAM GmbH
Dinnendahlstraße 9
44809 Bochum
Kennnummer: 0158
Bescheinigung: BVS 04 A

Bargteheide, 28.02.2019

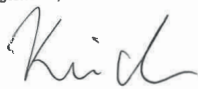

U. Küchenmeister
Geschäftsleitung



Dr
Technische



GETRIEBEBAU NORD
Member of the NORD DRIVESYSTEMS Group

Getriebebau NORD GmbH & Co. KG
Getriebebau-Nord-Str. 1, 22941 Bargteheide, Germany . Fon. +49(0)4532 289 - 0, Fax +49(0)4532 289 - 2253 . info@nord.com

EU-Konformitätserklärung
Im Sinne der EU-Richtlinie 2014/34/EU Anhang VIII

Hiermit erklärt Getriebebau NORD GmbH & Co. KG, Seite 1 von 1
dass die Getriebe und Getriebemotoren der Produktreihen

- **Stirnradgetriebe**
Typ SK ...
- **Schneckengetriebe**
Typ SK 02..., SK 1Sl., SK 12..., SK 13...,
SK 3..., SK 4....
- **Flachgetriebe**
Typ SK ...82, SK ...82.1,
SK ..82NB
- **Kegelradgetriebe**
Typ SK 9....

mit der ATEX-Kennzeichnung  II 3D / 3G

der folgenden Richtlinie entsprechen:
ATEX-Richtlinie für Produkte **2014/34/EU**

Angewandte Normen:

DIN EN 1127-1:	2011
DIN EN ISO 80079-36:	2016
DIN EN ISO 80079-37:	2016
DIN EN 60079-0:	2014

Bargteheide, 28.02.2019



U. Küchenmeister
Geschäftsleitung

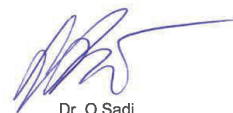

Dr. O. Sadi
Technische Geschäftsleitung

Notes

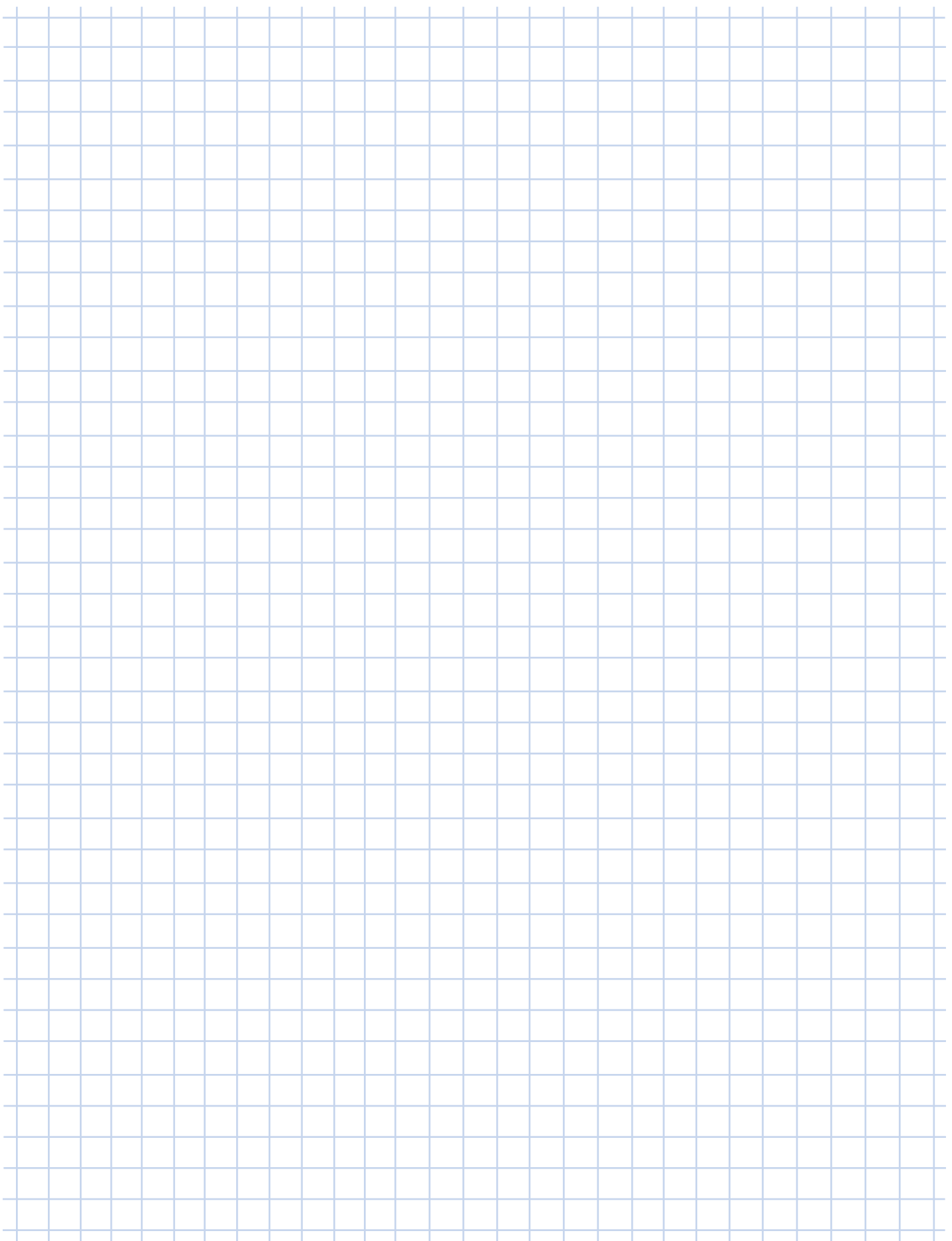



Hybrid mixtures

Both the gear units and motors, which are used in the context of explosion protection, take into account the specific requirements of the respective explosive substance.

For example, gases may penetrate into cavities in the motor or terminal box, which must be taken into account during construction.

Dust, on the other hand, is prevented by IP55 or higher protection from accumulating in the motor in an ignitable concentration, which facilitates the motor design on this point and saves costs.

In contrast, in the case of motors in a dust environment, electrostatic charging may occur more easily, which may result in hazardous corona discharge. In summary, it can be said that the ignition hazards in dust and gas atmospheres differ and result in specific technical solutions.

In rare cases, e.g. in mining, a mixture of flammable dust and flammable gas may occur - so-called hybrid mixtures. In the case of mining, this would typically be a mixture of methane, coal dust and air.

In view of the large number of flammable gases, dust and their resulting mixtures, the potential hazards are extremely numerous and complex.

The selection of a suitable drive can therefore not be made without the precise analysis of the situation on site. It must be acknowledged that a drive which can be used safely in a pure gas or dust atmosphere cannot provide an adequate level of safety in an environment with a hybrid mixture. In this case, the operator or plant constructor has to endeavour to avoid danger in the context of tertiary explosion protection - ie to reduce the effect of a possible explosion.

Currently no standard exists which provides specifications for the technical design of motors or gear units in environments with hybrid mixtures. NORD DRIVESYSTEMS therefore does not offer motors or gear units for this purpose.

For logistical reasons it may be advisable to use a drive unit which can be used in either an explosive gas or dust atmosphere. Here it should be weighed whether the higher price of the drive is outweighed by the flexibility gained. Such drives are offered by NORD DRIVESYSTEMS in the following combinations: 2G/2D, 2G/3D and 3G/3D.



The type plates of the gear unit and the motor indicate suitability for both gas and dust.



Hybrid mixtures

NORD drives
- 2G/2D, 2G/3D, 3G/3D

Example
- 2G/2D drive,

Hybrid mixtures

		Getriebebau NORD GmbH & Co. KG 22939 Bargteheide/GERMANY			
Type SK 52 F – IEC 112 /2G /2D					
No. 201234567					
n ₂ 18		min ⁻¹ n ₁ 1440		iges 26,46	
M ₂ 701		Nm P ₁ 4		IM M1	
F _{R2}		kN F _{R1}		kW Bj 01/16	
F _{A2}		kN		T _u -20/+40 °C	
Oil CLP PG 220 / 0,25l		kg		x _{R2}	
		II 2G Ex h IIC T4 Gb		MI 33054	
		II 2D Ex h IIC T125°C Db		S	

		0158					
D-32008 Herford							
3-Mot. DDEx 112 M/4 K		No. 2018xxxxx					
BVS 14 ATEX E 114 X / IECEX BVS 14.0075X							
II 2G Ex de IIC T4 Gb / Ex de IIC T4 Db							
or II 2D Ex tb IIC T135°C Db / or Ex tb IIC T135°C Db							
I.Cl. F		IP 55		IM		60 kg	
V		Hz		kW		A cos φ r/min I _A / I _N	
D 380-415		50		4,0		8,0 0,81 1440 6,8	
Y 660-720		50		4,0		4,6 0,81 1440 6,8	
D 440-480		60		4,8		8,2 0,83 1730 6,4	
S1-S9 1xM32x1,5 + 1xM20x1,5							
PTC		3x 145°C		t _A =21s		T _a	

Notes

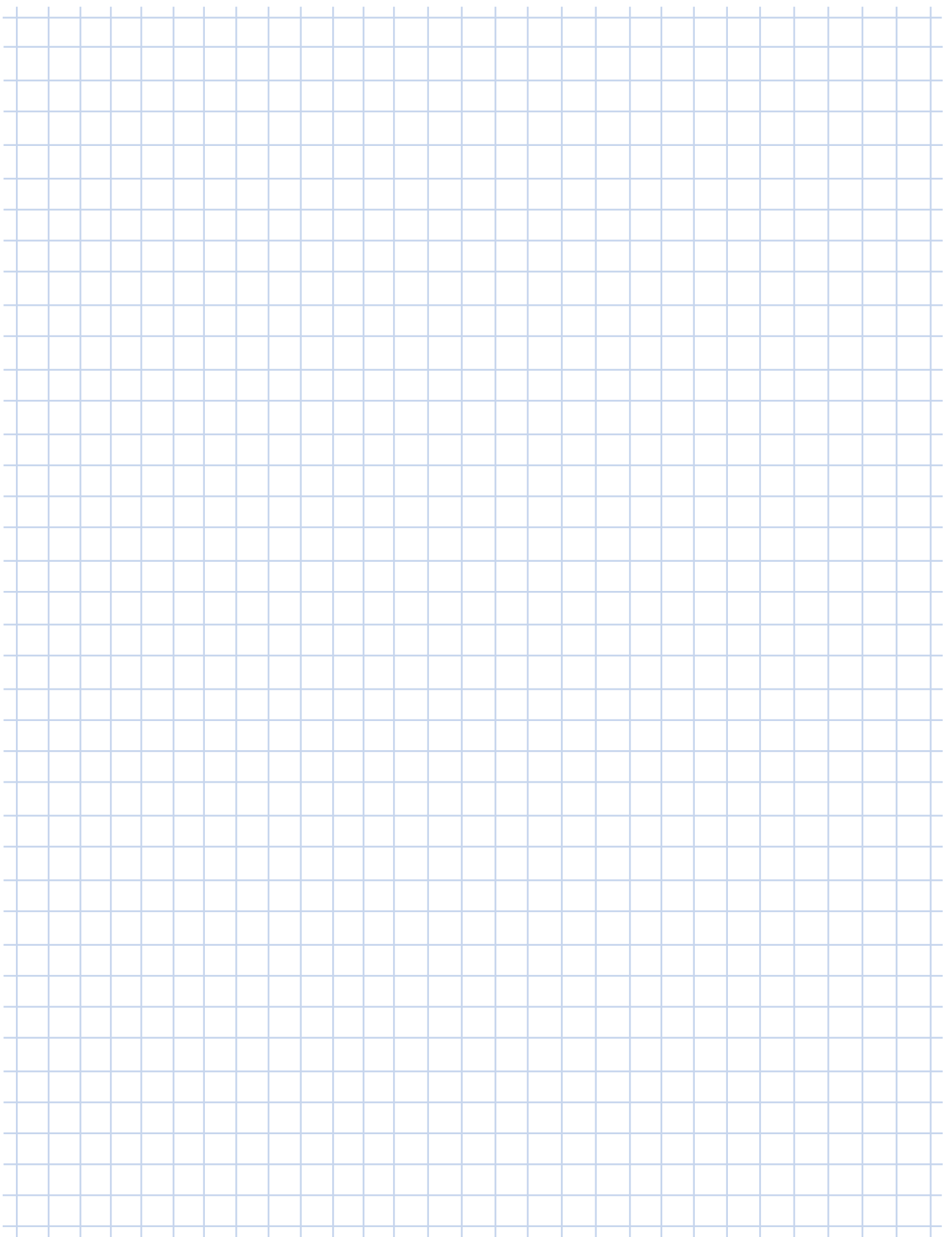

Cooling systems

Compliance with the maximum permissible temperatures is of great importance in explosion protection. External application-related influences, a high power density in the gear unit, high speeds, as well as gear unit installation with maximum oil level in the gear unit may lead to gear units having to be cooled. For this purpose, NORD offers both water coolers as well as oil/air coolers for cooling gear units.

Water cooling

Gear unit option CC: Casing cover with cooling spiral

An integrated heat exchanger is optionally available for parallel shaft gear units and bevel gear units. The cooling water flows through the heat exchanger, and cools the gear unit. Monitoring of the temperature or the cooling water flow is recommended. As the cooling coil is not located in the oil space, the NORD water cooling design is very safe (German industrial design registration 20 2005 005 452.6).

Integrated heat exchanger

NORD water cooling

Water cooling is also suitable for use in areas with potentially explosive atmospheres (ATEX).

Parallel shaft gear units	Installation orientation					
	M1	M2	M3	M4	M5	M6
SK 6282 / SK 6382	✓	✓		✓	✓	✓
SK 7282 / SK 7382	✓	✓		✓	✓	✓
SK 8282 / SK 8382	✓	✓		✓	✓	✓
SK 9282 / SK 9382	✓	✓		✓	✓	✓
SK 10382.1 **	✓	✓		✓	✓	✓
SK 11382.1 **	✓	✓		✓	✓	✓

Possible mounting position for water cooling

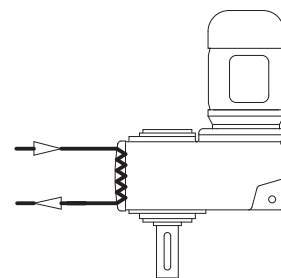

Bevel gear units	Installation orientation					
	M1	M2	M3	M4	M5	M6
SK 9072.1 *	○		✓	✓	○	○
SK 9082.1	○		✓	✓	○	○
SK 9086.1	○		✓	✓	○	○
SK 9092.1	○		✓	✓	○	○
SK 9096.1	○		✓	✓	○	○

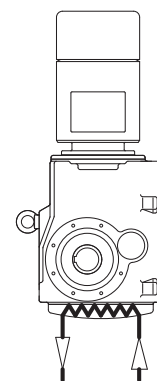

* Only available in versions AF(B), AZ... and VF, VZ ⇒  E104, E105, E133

** In preparation - Supply on request

✓ Full cooling power

○ Reduced cooling power

Cooling systems for gear units

Oil cooler

Gear unit option CS2

An oil/air cooler is a separate system which is connected to the gear unit with hoses which cools the oil in the gear unit and therefore directly reduces the surface temperature of the gear unit.

For this, the gear unit is drawn in by a pump and flows through a heat exchanger. The oil is cooled by an air stream which is generated by a fan. The oil is then returned to the housing from the heat exchanger. The temperature is controlled by a thermostat.

Temperature monitoring is necessary and is enabled by an Ex-compliant PT100 which is supplied with the system. Depending on the ambient temperature, the cooling power is approx. 5 kW.

Can be used for the following gear units

- Helical gear units SK62 – SK103
- Parallel shaft gear units SK6282 – SK11382.1
- Bevel gear units SK9072.1 – SK9096.1

The cooling system is suitable for

- II 2G Ex h IIB + H2 T4 GB
- II 3D Ex h IIIC T130°C Dc
- Ambient temperatures (hoses and cooler) in operation
 - Minimum +5°C with 2 m hose length
 - For $\geq +20^\circ\text{C}$ 2 or 4 m hoses can be used
- Max. ambient temperature +40°C
 - Higher temperatures on request

Planning of this cooling system is always carried out by experienced engineers, who modify the system to the special features of the application and the gear unit which is to be cooled.

Separate special documentation exists, which provides detailed information about the commissioning, operation and maintenance of the system.

Temperature-monitoring
- EX-compliant PT100

Commissioning, maintenance

Oil cooler

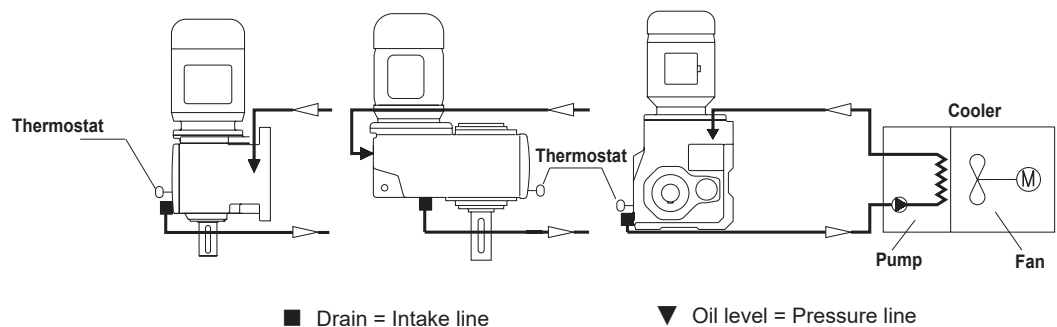
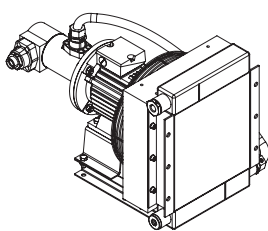

Delivery

Oil cooler, gear unit with special type plate, hose pack, PT100



Decentralised Product Group

NORD DRIVESYSTEMS understands decentralised inverters and starters to be devices which are mounted on the motor or mounted in the vicinity of the drive with the aid of wall mounting kits. This means that the devices must provide the same level of explosion protection as the drives with which they are associated. A 1:1 connection is required for this.

It is not permissible for an inverter to operate two motors simultaneously. NORD DRIVESYSTEMS is the manufacturer of all inverters and starters sold by NORD and can take all of the necessary measures from development and production up to quality control to ensure that the combination and electrics are ideally matched.

NORD has the following decentralised product groups which may all be installed in Ex Zone 22.

- **NORDAC Start motor starter SK 135E**

The motor starter NORDAC START is a decentralised wear-free electronic motor starter for soft starting of all kinds. It is equipped with a reversing function and internal motor protection and can therefore be flexibly integrated into any system.

- **NORDAC BASE – Frequency inverter SK 180E**

The NORDAC BASE is NORD's economical drive solution for the decentralised frequency inverter technology sector. With the NORDAC BASE, you purchase technology with a robust design that has been specially developed for simple drive solutions for installation outside the control cabinet at low cost.

- **NORDAC FLEX – Frequency inverter SK 200E**

Flexible to install, easy to service. The NORDAC FLEX is our most flexible inverter that can be tailored to any customer application by means of scalable functions. Installing and servicing the SK 200E can be carried out quickly and reliably due to its extensive plug-in capability and easy parameter transfer via EEPROM memory.

Decentralised product groups



Device	Within ATEX-Zone 22	Outside of a zone
NORDAC START	0.25 ... 7.5 kW	0.25 ... 7.5 kW
NORDAC BASE	0.25 ... 2.2 kW	0.25 ... 2.2 kW
NORDAC FLEX	0.55 ... 7.5 kW	0.55 ... 22 kW

Extensions for devices which are used within the ATEX zone:

- Internal CU4 modules / internal braking resistors
- ATEX Potentiometer
- Wall mounting kit without fan

Protection class	IP55	IP66
Non-conducting dust II3D Ex tc IIIB T125°C Dc X	Yes	
Conducting dust II3D Ex tc IIIC T125°C Dc X	-	Yes

Sealing of the devices is essential for safe and reliable operation. For this, special IP66 cable glands and exceptionally reliable housing seals are used. Conversions may only be made by NORD or by persons certified by NORD!

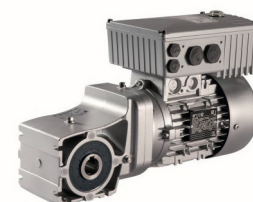

Frequency inverters and starters

Notice



Decentralised frequency inverters for „ATEX“ dust explosion protection



To ensure smooth commissioning, documentation is available in the following languages:

Available languages

Documentation	EN	EN	FR	ES	P	RU	PL	CN	US	CZE	IT	NL
BU 0135E	X	X	X	X	X	X	X					
BU 0180 / 0185	X	X	X	X	Y	X	Y	X		Y	Y	Y
BU 0200 / 0240	X	X	X	X	Y	X	X	X	X		Y	Y

X ⇒ Main instruction
Y ⇒ Brief instruction

Usable characteristic curves

The frequency inverters can be operated with variously set characteristic curves. The settings for this are stated in B1096. The following are possible:

- 50 Hz characteristic curve (only for ASM asynchronous motors)
- 60 Hz characteristic curve (only for ASM asynchronous motors)
- 87 Hz characteristic curve (only for ASM asynchronous motors)
- 100 Hz characteristic curve (for ASM)

Settings

It is essential that the following settings are complied with for operation:

- Pulse frequency 4 – 6 kHz
- Vector regulation
- Setting of the I²t trigger curve
- Maximum frequency 100 Hz
- Temperature sensor triggering must be used and tested

Options

The otherwise extensive range of options is reduced to just a few for starters and inverters which are operated in the Ex zone.

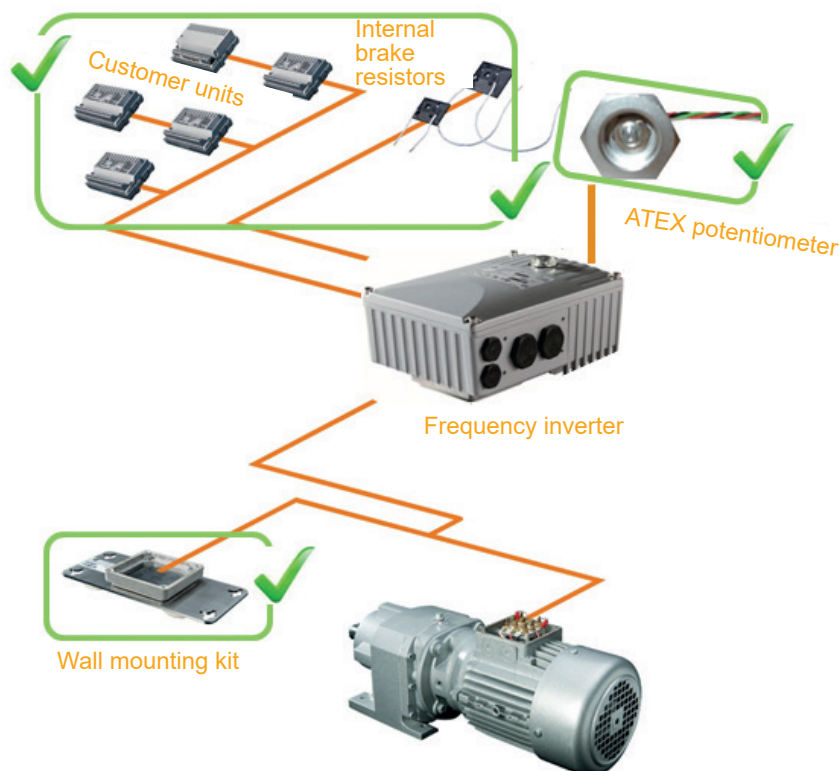



Frequency inverters and starters for installation outside of the Ex zone

For safe operation of motors within the Ex zone, motor manufacturers specify requirements for the technical design and settings of inverters and starters.

Details of these can be found in the relevant operating and maintenance instructions.

If the motors and inverters from the same manufacturer are used, it is very likely the devices will be in sync.

For explosion protection a 1:1 connection between the motor and the inverter is necessary. It is not permissible for an inverter to operate two motors simultaneously. NORD DRIVESYSTEMS is the manufacturer of all inverters and starters which are sold by NORD and can take all of the necessary measures from development and production up to quality control to ensure that the combination and electrics are ideally matched.

- **NORDAC LINK Motor starter SK155E**

One product, many advantages. The NORDAC LINK motor starter impresses with its high plug-in capability and its easy installation. It can be freely configured and easily installed. Commissioning and servicing of the motor starter is performed easily with the integrated maintenance switch and the local manual control facility. It can also be integrated into various field bus systems. In short: The SK 155E is simply convenient.

- **NORDDAC LINK Frequency inverter SK250E**

The NORDAC LINK is the convenient NORD drive solution for flexible decentralised installation. Depending on the application and the requirements, NORDAC LINK can be freely configured, which results in a large number of different potential applications for this inverter. The high level of plug-in capability enables fast and easy installation of the units. Commissioning and servicing of the system is performed quickly with the integrated maintenance switch and the local manual control facility. The NORDAC LINK can be integrated into all common bus systems.

- **NORDAC PRO Frequency inverter SK500E**

The NORDAC PRO is the inverter for all drive applications. It offers a wide power range, and its functionality can be extended with plug-in option modules. For this inverter, variable cooling concepts are used to remove heat, which can enable the removal of heat outside of the control cabinet and can be simply adapted to the requirements of the application with various option modules.

Device	Within ATEX-Zone 22	Outside of ATEX
NORDAC LINK (Starter)	--	0.25 ... 3 kW
NORDAC LINK (Inverter)	--	0.55 ... 7.5 kW
NORDAC PRO	--	0.25 ... 160 kW

Documentation	EN	EN	FR	ES	P	RU	PL	CN	US	CZE	IT	NL
BU 0155	X	X	X			X						
BU 0250	X	X	X			X						
BU 0500 / 0540	X	X	X	X	Y	X	X	X		X	Y	Y

Available languages

X ⇒ Main instruction
Y ⇒ Brief instruction

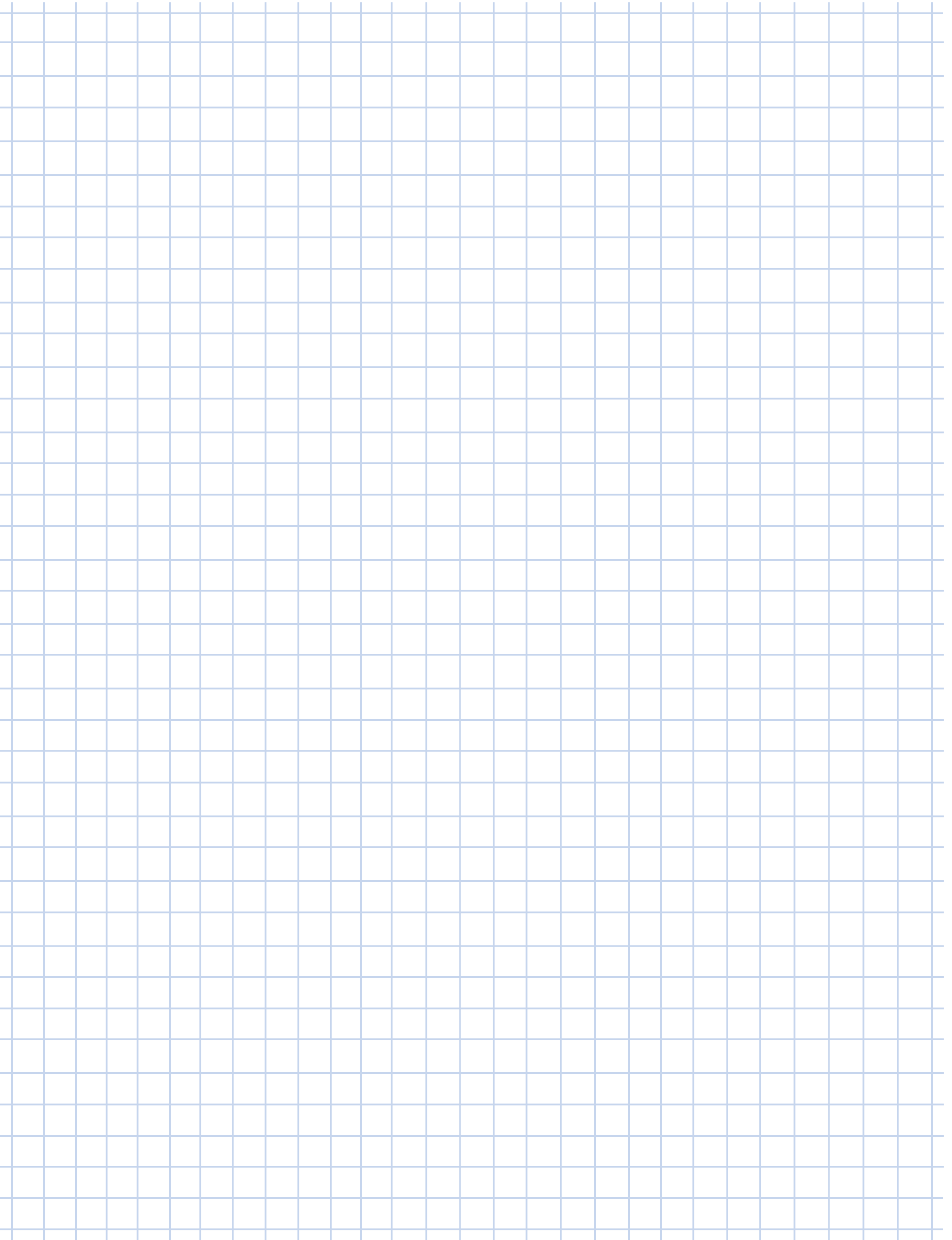

NORD DRIVESYSTEMS provides extensive documentation. It ranges from the description of the product groups gearboxes, motors and inverters in catalogues, to the provision of drawings and data sheets, to operating and maintenance instructions.

This section is intended to provide a brief overview.

Catalogues

This Ex-catalogue is a supplement to motor and gear unit catalogues M7000, G1000, G2000, G1012 and G1035.

These can provide important information for the selection of the gear unit as well as descriptions of the various kinds and types of gear units and their options. Possible speeds and gear ratios as well as the associated output torques are shown.

Use of Ex motors may result in slightly changed data, which can be obtained from the offer in case of an enquiry.

Motor catalogue M7000 contains information for motor selection and technical explanations.

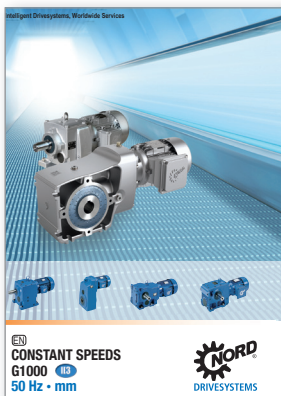

Drive Expert / MYNORD

The product configurator in the myNORD customer portal (www.mynord.com) is also available as an alternative to catalogues. In this, all drive units, including Ex drive units and their options can be selected for

- Precise configuration.
- Direct generation of CAD- data (3D models, dimensioned drawings, outline drawings).
- Create offers online

It must be emphasised that the configurator indicates whether or not a selected drive unit is ATEX compliant. Price information as well as an enquiry/order form are also included.

Here are some impressions from this program:

[HOME](#) | [MYNORD](#) | [PRODUCT SELECTION](#)

MYNORD PRODUCT SELECTION

Ordering process

ORDERS & QUOTES

PROJECTS

You don't have sufficient privileges to access the area 'projects'.

[ALL PROJECTS](#)

CONFIGURATIONS

You don't have sufficient privileges to access the area 'configurations'.

ORDERS

[ALL ORDERS](#)

Create new product / CAD

CREATE NEW PRODUCT / CAD

PRODUCT / CAD CONFIGURATOR

Create a new product & CAD configuration

Your project reference (optional)

XYZ

Product

Gear Unit

[CONFIGURE](#)

Product search for Geared Motors



- Fast product selection from the entire range of geared motors
- Search for motor power, output speed or torque
- Clear comparison of search results
- Sorting function

[START SEARCH](#)

Preview of possible partial results as a result of using this software. Please contact your NORD Sales contact partner for more detailed information.

NORDBLOC.1 GEARMOTOR

Type name: **SK 172.1F /3D - 63S/4 3D TF**

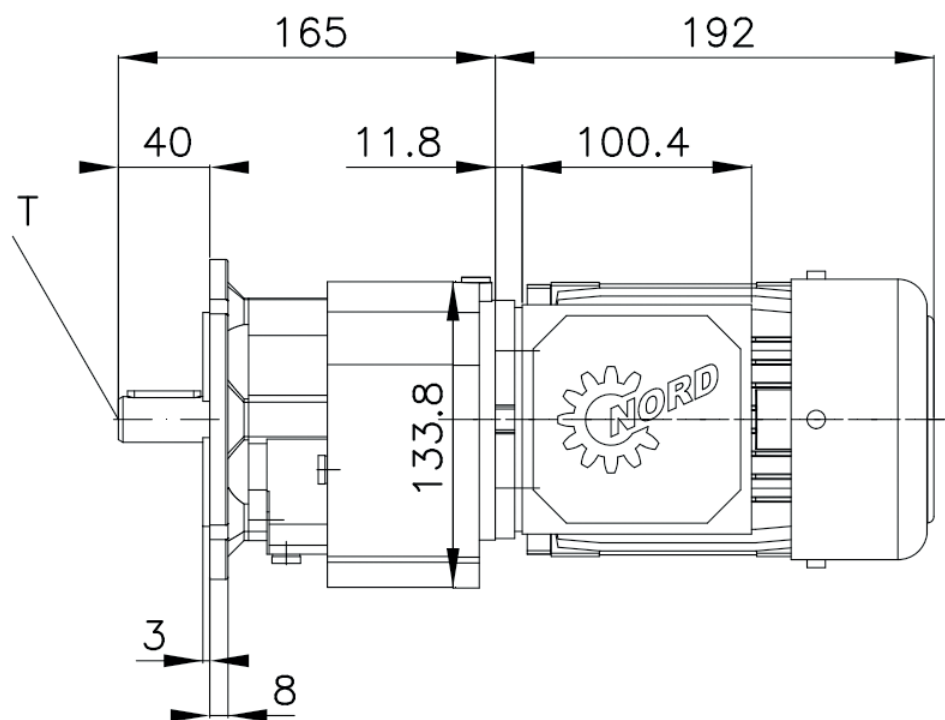

PRODUKT KONFIGURATION

DATENBLATT

▼ GETRIEBEMOTOR

Motorleistung (Pn2)	0.12 kW
Drehzahl (n22)	146 1/min
Drehmoment (Ma2)	7.7 Nm
Betriebsfaktor (fB2)	2.2

▼ GETRIEBE

Abtriebsdrehzahl (n2_05)	151 1/min
Max. Drehmoment (Ma_05)	17 Nm
Eingangsdrehzahl (05)	1400 1/min
Eingangsdrehzahl (04)	930 1/min
Abtriebsdrehzahl (n2_04)	100 1/min
Max. Drehmoment (Ma_04)	17 Nm
Eingangsdrehzahl (03)	700 1/min
Abtriebsdrehzahl (n2_03)	75 1/min
Max. Drehmoment (Ma_03)	17 Nm
Eingangsdrehzahl (02)	450 1/min
Abtriebsdrehzahl (n2_02)	48 1/min
Max. Drehmoment (Ma_02)	17 Nm
Eingangsdrehzahl (01)	250 1/min
Abtriebsdrehzahl (n2_01)	27 1/min
Max. Drehmoment (Ma_01)	17 Nm
Ölmenge Hauptgetriebe	0.22

Motorleistung (Pn2)	0.12	kW
Drehzahl (nn2)	1385	1/min
Motor Betriebsfaktor 2	1.00	
Strom (In1)	0.88	A
Strom (In2)	0.51	A
Wirkungsgrad 2 (100%)	50.5	%
Nenndrehmoment (Mn)	0.83	Nm
Massenträgheitsmoment	0.00021	kgm ²
Synchrondrehzahl	1500	1/min
Leistungsfaktor 2	0.62	
Zulässige Umgebungstemperatur	40	°C
Maximale Aufstellhöhe	1000	m
Isolationsklasse	F	
Temperaturklasse	B	
Isolationswiderstand	100	MOhm
Spannung 1	230	VAC
Spannung 2	400	VAC
Phase	3	
Ständerschaltung	D/Y	
Frequenz	50	Hz
Ma/Mn	2.8	
Kippmoment (Mk/Mn2)	2.8	
Ia/In	3.26	
Sattelmoment (Ms / Mn2)	2.7	
Motorlieferant	NORD	
Schalldruckpegel LPA	40	dB
ATEX Staub OT	125	
Einschaltdauer	S1	

Documentation accompanying the order

All deliveries of Ex drives to destination countries in the EU contain complete printed documentation in German, as well as in a language which can easily be understood by the operator.

Customers are requested to state the required language in their request for an offer.

- For Ex gear units, **B2000** is supplied, which specifically deals with explosion protection,
- **B1091** is intended for main operating motors,
- **B1091** and **B1091-1** are intended for motors operated with inverters,
- For use of motor mounted inverters for **Zone 22** documents **B1091**, **B1091-1** and **G4014-1** are supplied.

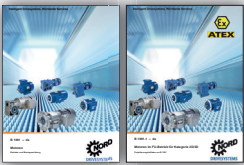

NORD homepage

All operating and maintenance instructions, spare parts lists and certificates can be found under www.nord.com.



▶ Getriebebau NORD GmbH & Co. KG  ▶ Contact [ENGLISH](#)

DRIVESYSTEMS

Products

myNORD

Documentation

Industries

NORD

Documentation

To ensure that we always understand you, we communicate with our customers in 20 different languages.



▶ Manuals



▶ Catalogues



▶ Flyers/Brochures

Rapid access enables a targeted search for documents:

[Home](#) | [Documentation](#) | [Certificates](#)

Certificates

Direct Access

Selection Results. 5 found in English, 54 found in other languages

TITLE	LANGUAGE(S)	VERSION	TYPE	DOWNLOAD
Declaration of conformity - ATEX 2D NORD Motors - frame size: 63 - 200 (C422110)	English Other languages	2018	ATEX	PDF (107 KB)
Declaration of conformity - ATEX 3D NORD Motors - frame size: 63 - 250 (C422111)	English Other languages	2019	ATEX	PDF (62 KB)
EG-Type Test Certificate - ATEX 2D NORD Motors (C422120_2004)	English Other languages		ATEX	PDF (637 KB)
EG-Type Test Certificate - ATEX 2D NORD Motors, 4th Supplement (C422121_2004)	English Other languages		ATEX	PDF (449 KB)
EG-Type Test Certificate - ATEX 2D NORD Motors (C422122_2013)	English Other languages		ATEX	PDF (351 KB)

If the name of the document is known, the "search" will be successful.

[Getriebebau NORD GmbH & Co. KG](#)  [Contact](#) [myNORD Login](#)
[ENGLISH](#)

G4014-1

[Products](#) | [myNORD](#) | [Documentation](#) | [Industries](#) | [NORD Group](#)

[Home](#) | [Global](#)

Search results

Showing 1 - 10 of 2006 for "G4014-1"

- 
[NORD - Electronic Variable Speed Drives\(G4014-1 \)](#)
 Manual Electronic Variable Speed Drives >
- 
[NORD - Electronic Variable Speed Drives\(G4014-1 \)](#)
 Catalogues Electronic Variable Speed Drives >

Accompanying information material:

- Manuals: German, English, French, Spanish ...
- Poster: Gas, dust
- Source: ⇒ Sharepoint
 - ⇒ Presentation + Training
 - ⇒ Poster + Manual
 - ⇒ ATEX

Abbreviations

2D	Category 2D
3D	Category 3D (non-conducting dust)

ATEX:	ATmosphères EXplosibles
DIN	Deutsches Institut für Normung e.V. [<i>German Standards Institute</i>]
EN	European standard

IE1	Efficiency as per IE1
IE2	Efficiency as per IE2
V/f	Voltage/frequency characteristic curve

Legend / Formula symbols

cos φ	Power factor
T_u	Ambient temperature [°C]
T125 / T140	max. surface temperature [°C]
f_s	Stator frequency [Hz]
f_N	Nominal frequency [Hz]
I_N	Nominal motor current [A]

M	Torque [Nm] or [%]
n	Speed [rpm]
P_N	Rated power [kW]
R_{St}	Resistance on line [Ω]
U_N	Rated voltage [V]

An overview of NORD range

G1000 Fixed speeds

UNICASE housing 50 Hz, 60 Hz

- Helical geared motors
- Parallel geared motors
- Bevel geared motors
- Helical worm geared motors

G4014 Electronic variable speed drives

- NORDBLOC.1 Helical geared motors
- Helical geared motors
- Parallel geared motors
- Bevel geared motors
- Helical worm geared motors

G1050 MAXXDRIVE® Industrial gear units

UNICASE housing 50 / 60 Hz

- Parallel-Axis
- Right-Angle

G1035 UNIVERSAL Worm gear units

- SI and SMI

F3018_E3000 Frequency inverter SK180E

F3020_E3000 Frequency inverter SK200E

**F3060_E3000 NORDAC PRO
Frequency inverter SK500P**



Intelligent Drivesystems, Worldwide Services

NORD DRIVESYSTEMS® Group

Headquarters and Technology center
in Bargteheide, Germany, close to Hamburg

Innovative drive solutions
for more than 100 branches of industry

Mechanical products
parallell shaft, helical gear, bevel gear and worm gear units

Electrical products
IE2/IE3/IE4 motors

Electronic products
centralised and decentralised frequency inverters,
motor starters and field distribution systems

Seven state-of-the-art production plants
for all drive components

Subsidiaries and distributors
in 98 countries on 5 continents
provide local stocks, assembly, production,
technical support and customer service

More than 4,000 employees throughout the world
create customer oriented solutions

www.nord.com/locator

Headquarters:

Getriebebau NORD GmbH & Co. KG
Getriebebau-Nord-Straße 1
22941 Bargteheide, Germany
Fon +49 (0) 4532 / 289-0
Fax +49 (0) 4532 / 289-2253
info@nord.com, www.nord.com

Member of the NORD DRIVESYSTEMS Group

