

Intelligent Drivesystems, Worldwide Services

# IE4/IE5 SYNCHRONOUS MOTORS



EN

TECHNICAL INFORMATION

SYNCHRONOUS MOTORS 0.35 - 5.50 kW

T160-0001

IE4

IE5

  
DRIVESYSTEMS

# Contents

---

<b>Introduction</b> . . . . .	2 - 5
<b>Synchronous motors: Options</b> . . . . .	6 - 10
<b>Brake motors</b> . . . . .	12 - 14
<b>Planning information</b> . . . . .	15 - 22
<b>Synchronous motors: Motor data</b> . . . . .	24 - 32
<b>Synchronous motors: Dimensioned drawings</b>	34 - 43





## Headquarters and Technology Centre

- In Bargteheide, near Hamburg

### Industrial gear units

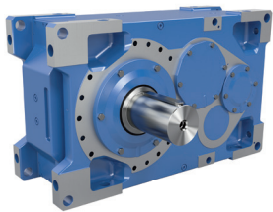

### Geared motors

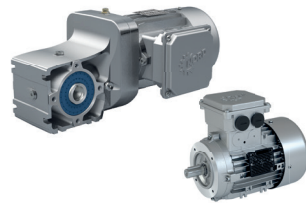

### Electronic products

Frequency inverters, motor starters and field distributors



## Innovative drive solutions

- for more than 100 branches of industry



Gear unit production



Motor production



Inverter production

## 7 production locations with cutting edge technology

- Produce gear units, motors, frequency inverters, etc. for complete drive systems from a single source



The map shown above is for information only and does not claim to be created for or applicable to any legal purpose. For this reason, we do not assume any liability for legality, correctness and completeness.

## Subsidiaries and sales partners in 98 countries on 5 continents

- Provide local supplies
- Assembly centres
- Technical support
- Customer service



## More than 4,000 employees worldwide

- Create customised solutions

# NORD IE4/IE5 SYNCHRONOUS MOTORS

IE4



## High-efficiency IE4/IE5 motors

The IEC 60034-30-2:2016 / DIN VDE 0530-30-2:2019-02 standard defines the efficiency requirements for electric motors by way of efficiency data. Synchronous motors from NORD DRIVESYSTEMS based on permanent magnet technology correspondingly ensure high levels of efficiency. The systems achieve these high torques and exceptionally high efficiencies (IE4 and better) even at low speeds. The motors for energy-optimised systems are exclusively designed for operation with the frequency inverter.

NORD supplies synchronous motors with powers between 0.35 and 5.50 kW.

NEW

IE5



The new IE5+ motor generation expands the current synchronous motor series for lower power ranges.

The energy-efficient latest generation permanent magnet synchronous motor has considerably lower losses than the current IE4 series.

The motor achieves its high efficiency that, at times, is significantly above efficiency class IE5 via a wide torque range – and is optimally suitable for the operation in the partial load range. The compact IE5+ motor offers a high power density with less installation space:

- Lower operating costs – thanks to high efficiency synchronous motors with permanent magnet technology
- Simple and highly flexible combination – through full compatibility with the NORD modular system
- Simplified control of applications – thanks to almost constant motor speed

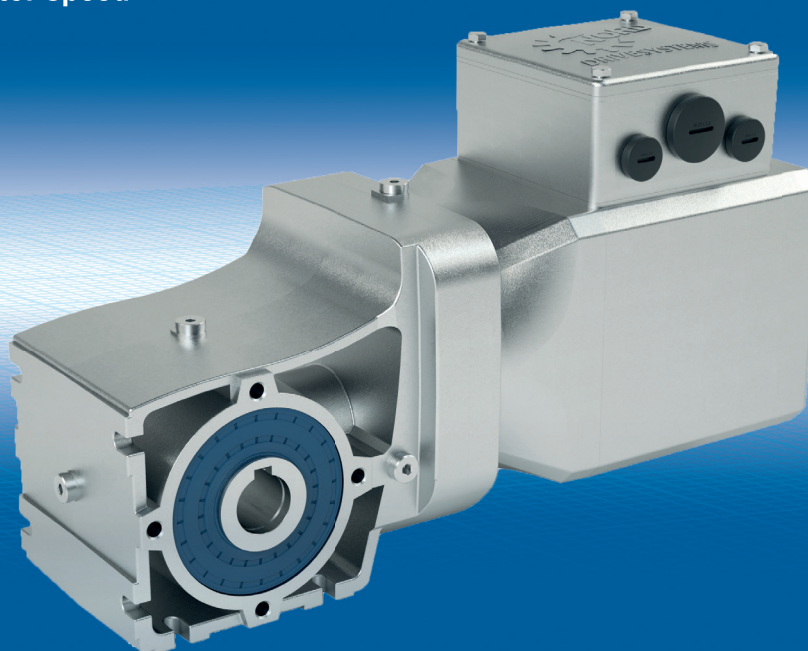

The new IE5+ motor generation is especially suitable for reducing operating costs in wash-down applications:

- Highest operational efficiency
- Reduced TCO and fast ROI
- Reduced number of versions through constant torque over a wide speed range
- Especially easy to clean and corrosion-resistant due to smooth and fan-less motor design
- Fully matched NORD modular system solution with inverter, gear unit and motor
- Compact and hygienic design for ultimate application diversity

### Features:

- Latest generation permanent magnet synchronous motor (PMSM)
- Lower range from 0.35 to 1.1 kW in a single size
- IEC B14 flange mounting, IEC B5 flange mounting, NEMA C-face flange mounting, direct mounting to all NORD gear units
- Continuous torque of 1.6 to 4.8 Nm in a single size
- Speed range from 0 to 2,100 rpm
- Optionally with nsd tupH surface treatment and IP69K protection class
- Motor-integrated encoder and integrated mechanical brake optional

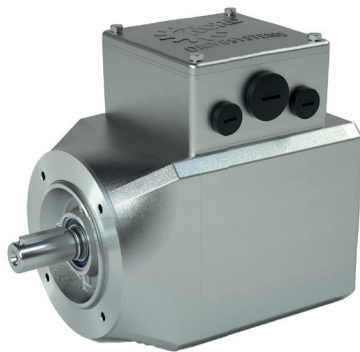

NORD IE5+ Synchronous motor

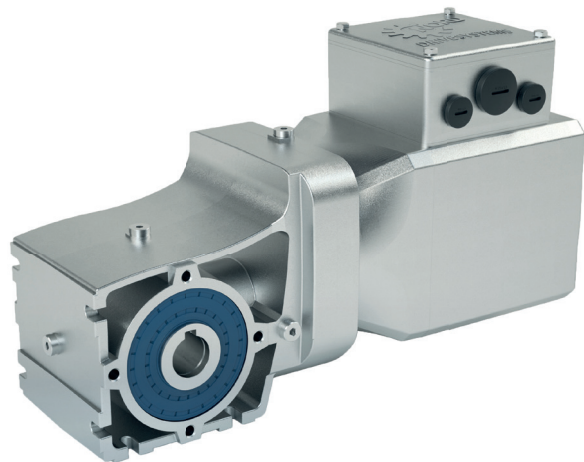

Bevel gear unit SK 92072.1  
NORD-IE5+ Synchronous motor

Further information can be found in:

Flyer S9012



M7000 asynchronous motors



Application guide - PMSM -  
Drive optimisation AG0101



T160-004



# NORD IE4/IE5 MOTOR DATA

Axis height: 71, 80, 90, 100

T=2,100 rpm with star circuit, 3,000 rpm with delta circuit N = Non-ventilated

Package length: 1..9 code depends on length and axis height

Number of poles

80 D 1 /4...8

Size	M <sub>N</sub> [Nm]	P <sub>N</sub> [kW]	n <sub>N</sub> [rpm]	I [A]	η	J [kgm <sup>2</sup> ]	m [kg]	M <sub>max</sub> [Nm]	K <sub>T</sub> [Nm/A]	K <sub>E</sub> [mV/rpm]
71N1/8	1.60	0.35	2100	0.76	89.1	0.00019	4.90	4.80	2.11	143
71N2/8	3.20	0.70	2100	1.45	92.5	0.00038	6.00	9.60	2.21	144
71N3/8	4.80	1.10	2100	2.14	93.6	0.00057	7.00	14.4	2.24	144
80T1/4	5.00	1.10	2100	2.07	90.5	0.0011	8.00	14.4	2.50	154
80T1/4 Δ	4.80	1.50	3000	3.44	90.4				1.40	89
80T1/4 HM	3.41	0.75	2100	1.46	90.5	0.0011	7.80	13.5	2.30	154
90T1/4	6.80	1.50	2100	2.82	89.9	0.0019	10.0	21.0	2.40	156
90T1/4 Δ	7.00	2.20	3000	5.09	89.6				1.40	90
90T3/4	10.0	2.20	2100	4.13	90.5	0.0024	12.0	29.0	2.40	158
90T3/4 Δ	9.50	3.00	3000	6.84	92.3				1.40	91
90T3/4 HM	5.00	1.10	2100	2.08	92.7	0.0024	11.6	28.3	2.40	156
100T2/4	13.6	3.00	2100	5.40	91.4	0.0046	18.0	42.0	2.60	161
100T2/4 Δ	12.7	4.00	3000	8.90	92.1				1.50	93
100T5/4	18.2	4.00	2100	7.10	92.1	0.0060	21.0	57.0	2.60	165
100T5/4 Δ	17.5	5.50	3000	11.9	92.2				1.50	95
100T5/4 HM	10.0	2.20	2100	4.16	91.0	0.0060	21.0	53.5	2.40	165

### IE5+ synchronous motor

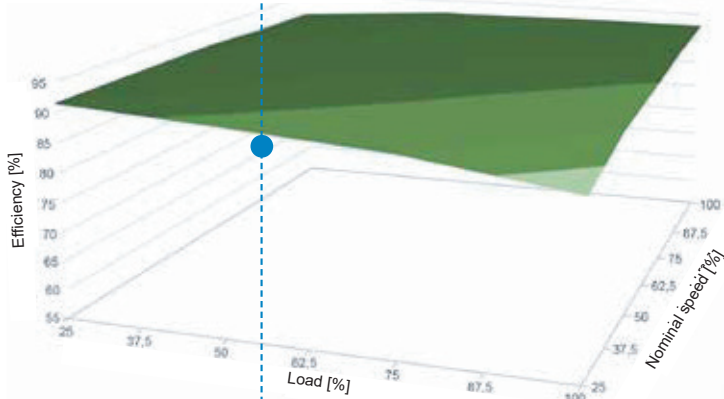

### IE4 synchronous motor

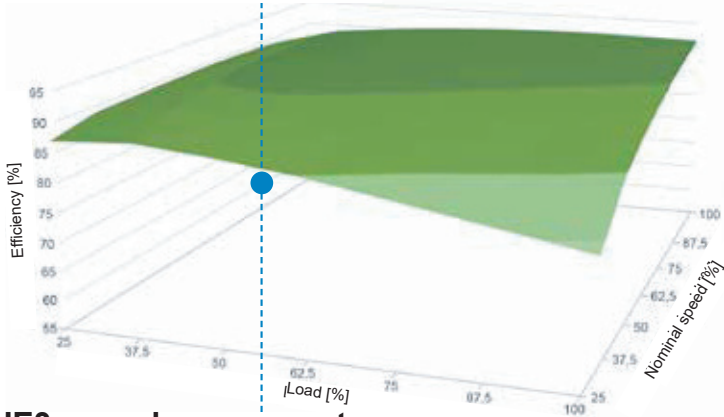

### IE3 asynchronous motor

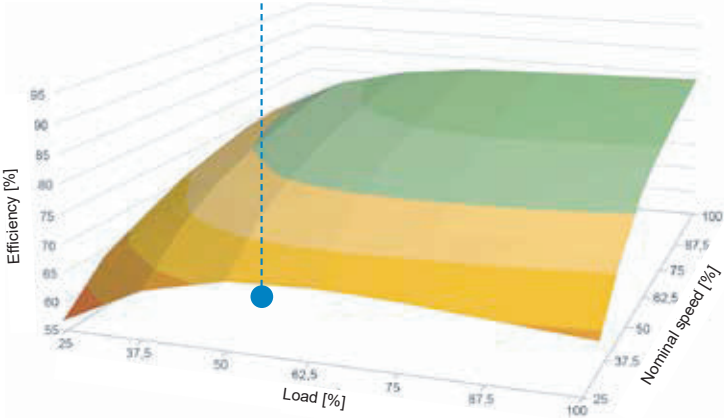

The new IE5+ synchronous motor is characterised by its very high efficiency. Compared to asynchronous motors, high energy savings are possible, especially in the partial load and partial speed range.\* This minimises the customer's TCO.

\* Efficiency example: Load 50 % / speed 37.5 %





## Available motor options for IE4 PMSM 1.10 - 5.50 kW motor series

Abbreviation		Meaning
BRE +		Brake/brake torque + suboption
	RG *	Rust-protected version
	SR *	Dust- and rust-protected version
	FHL *	Lockable manual release
	HL	Manual release
	MIK	Microswitch
NRB1 / 2		Noise-reduced brake
ERD		External earthing terminal
TF		Temperature sensor, PTC resistor
TW		Thermostat, bimetallic
SH		Anti-condensation heater
WE +		2nd shaft journal
	HR	Hand wheel
RD		Protective shield
RDT		Protective shield, textile fan cover
RDD		Double fan cover
OL		Without fan
OL/H		Without fan, without cover
KB		Closed condensation drain hole
MS		Motor plug connection
EKK		One-piece terminal box
KKV		Encapsulated terminal box
FEU		Humidity protection insulation
TRO		Tropical protection insulation
F		External fan
RLS		Backstop
IG1	(IG11, 12)	Incremental encoder, 1024 pulses
IG2	(IG21, 22)	Incremental encoder, 2048 pulses
IG4	(IG41, 42)	Incremental encoder, 4096 pulses
MG		Magnetic incremental encoder
IG.P		Incremental encoder with plug connector
IG.K		Encoder with terminal box
AG		Absolute encoder

\* For more information, see motor catalogue M7000





## Available motor options for IE5+ PMSM 0.35 – 1.1 kW motor series

Abbreviation		Description
TF		Temperature sensor, PTC resistor
IP69K		IP69K protection class
BRE		Holding brake
MS		MS31, MS32, MS21, MSR, MSR VA
nsd tupH		nsd tupH surface treatment
IG6	(IG6, IG61, IG62)	Incremental encoder, 2048 pulses
IGxxP	(IG62P5, IG61P8, IG62P5)	Incremental encoder with 5-pin or 8-pin plug connector

### Thermal motor protection

A sensible motor selection protects the motor against overheating caused by the application or the ambient conditions. Factors that could lead to overheating of the motor are, for example

- Overload
- High ambient temperatures
- Restricted supply of cooling air
- Low motor speed due to frequency inverter operation.

NORD IE5+ motors are equipped with thermal motor protection.

**TF** = PTC resistor temperature sensor

This is used to directly monitor the winding temperatures with full utilisation of the motor power.

Three TF temperature sensors (one for each strand) connected in series are located at the hottest points of the windings. They are connected to 2 terminals in the terminal box.

When the rated trigger temperature (NAT) is reached, the resistance of the temperature sensor suddenly increases to almost 10x its normal value.

Trigger temperature: 135° C voltage max. 30 V terminals TP1 + TP2

The PTC temperature sensor only performs its protective function when connected to a trigger device!

A triggering device evaluates the resistance increase and switches the drive off.



## Encoders

### Incremental encoder (IG)

Modern drive applications often require speed feedback. Normally incremental encoders, which convert rotary movement into electrical signals, are used for this.

These signals are read out and processed by frequency inverters or other control devices. The incremental encoder of the IE5+ motor works according to a magnetic principle. The rotary encoder consists of two components: the magnet wheel mounted on the motor shaft, and the sensor circuit board.

The integrated electronics converts the measuring signals into a digitalised square wave signal according to TTL or HTL logic.

The following configurations can be implemented in combination with NORD frequency inverters:

- Speed control with large adjustment range
- Highly accurate speeds, independent of the load
- Synchronisation control
- Position control
- Standstill torques
- High overload reserves

Technical data	Type / Number of pulses		
	IG6	IG61	IG62
Interface	RS 485	TTL	HTL
Operating voltage +U <sub>B</sub> [V]	10 ... 30	10 ... 30	10 ... 30
Max. operating speed [rpm]	4000		
Ambient temperature [°C]	-25 ... +90		
Protection class	Corresponds to the motor protection class		
Max current consumption [mA]	400	400	400



## Incremental encoder mounting

The incremental encoder is fully integrated into the motor housing and is available for all variants of the IE5+ motor. This type of motor integration fully protects the encoder system against environmental influences.

Electrical connection is established via a flanged connector in the terminal box of the motor. Depending on the encoder variant, 5-pin or 8-pin connectors are available. The appropriate signal cable can also be supplied upon request.

### Incremental encoder with 5-pin plug connector (IGxxP5)

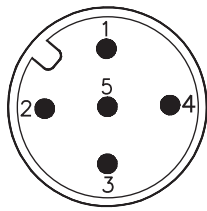
PIN	Signal	Encoder connection configuration
1	+V	
2	B	
3	0 V	
4	A	
5	0	

### Incremental encoder with 8-pin plug connector (IGxxP8)

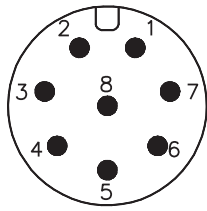
PIN	Signal	Encoder connection configuration
1	0 V	
2	+ U <sub>B</sub>	
3	A	
4	A\	
5	B	
6	B\	
7	0	
8	0\	

Selection of the encoder according to the output logic is determined by the interface of the evaluation electronics. The following conditions apply to NORD frequency inverters:

NORD frequency inverter series	Incremental encoder logic
SK500P, SK510P	HTL mit 10 – 30V Versorgung
SK530P, SK550P	TTL mit 10 – 30V Versorgung
SK520E, SK530E, SK535E, SK540E, SK545E	TTL mit 10 – 30V Versorgung
SK200E, SK205E, SK210E, SK215E, SK220E, SK225E, SK230E, SK235E	HTL with 10 – 30V supply
NORDAC LINK	HTL with 10 – 30V supply

For further details, please refer to the operating instructions for the frequency inverter, e.g. BU 0500E. An external electronic module to convert HTL into TTL signals (e.g. connection of the encoder to 530P with very long cables) is available from NORD.



## Motor plug connection (MS)

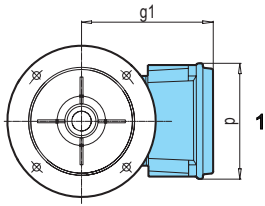
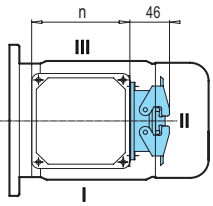

### Normal version

Terminal box for 1, plug connector for II (to fan cowl),  
plug connector possible for I + III

If desired, the IE5+ motors can also be supplied with motor plug connectors.  
The following standard motor plug connectors are available:

- Motor plug connector MS21 (HAN Q8)
- Motor plug connector MS31 / MS32 (HAN 10E)
- Motor plug connector MSR / MSR VA

### Motor plug connector MS21



#### - Technical data:

Plug connectors: HAN Q8  
Number of pins: 10  
Current: 16 A max.  
Voltage: 500 V max. (600 V max. according to UL/CSA)  
Cage-clamp termination

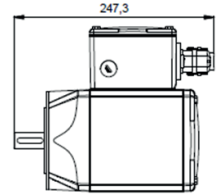
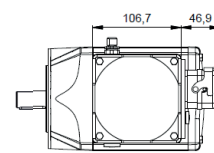
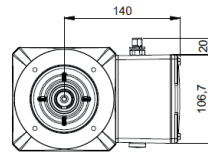

### Motor plug connector MS31 / 32 / 31E / 32E



#### - Technical data:

Plug connectors: HAN 10 ES/  
HAN ESS  
Number of pins: 10  
Current: 16 A max.  
Voltage: 500 V max. (600 V max. according to UL/CSA)  
Cage-clamp termination

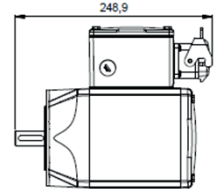
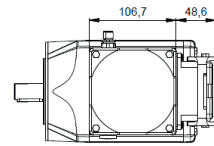
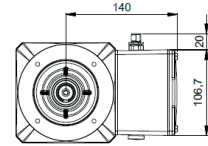

with EMC protection

The MS31E and MS32E motor plug connectors are suited for applications where increased electromagnetic compatibility (EMC protection) is required.

### Motor plug connector MSR / MSR VA



#### - Technical data:

Plug connectors: M20 x 1.5 female motor thread with  
M23 x 1.0 connection thread  
Number of pins: 8-pin (4 + 3+ PE)  
Current: 28 A max.  
Voltage: 600 V max.

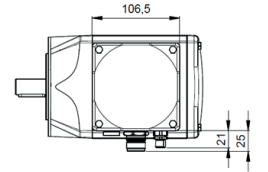
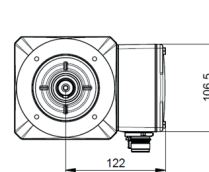

VA version

Optionally available in stainless steel.

The motor plug connectors are supplied without the matching connector and have a protective cap to protect against dirt.

Matching connectors are available upon request.

---

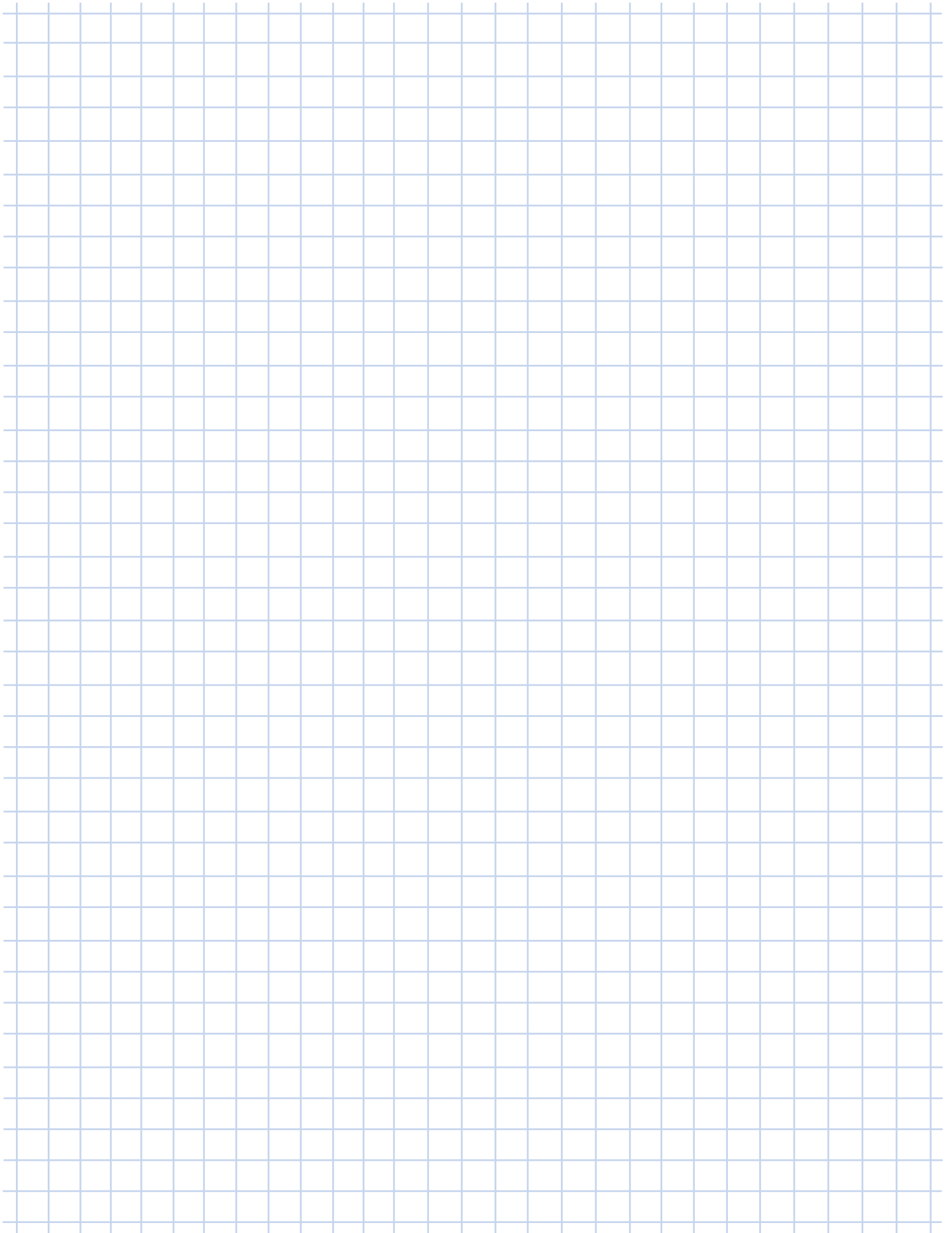

## Brakes - standard assignment for IE4/IE5 motors

Motor		M <sub>N</sub> [Nm]	P <sub>N</sub> [kW]	n <sub>N</sub> [rpm]	BRE 5		BRE 10		BRE 20		BRE 40		BRE 60	
					M <sub>B</sub> [Nm]	f <sub>B</sub>	M <sub>B</sub> [Nm]	f <sub>B</sub>	M <sub>B</sub> [Nm]	f <sub>B</sub>	M <sub>B</sub> [Nm]	f <sub>B</sub>	M <sub>B</sub> [Nm]	f <sub>B</sub>
IE5	71N1/8 <sup>1)</sup>	1.60	0.35	2100	2.5	1.5								
	71N2/8 <sup>1)</sup>	3.20	0.70	2100	5.0	1.5								
	71N3/8 <sup>1)</sup>	4.80	1.10	2100	5.0	1.0								
IE4	80T1/4	5.00	1.10	2100	5.0	1.0	<b>10</b>	2.0	20 *	4.0				
	80T1/4 Δ	4.80	1.50	3000	5.0	1.0	<b>10</b>	2.1	20 *	4.2				
	90T1/4	6.80	1.50	2100			10	1.5	<b>20</b>	2.9	40 *	5.9		
	90T1/4 Δ	7.00	2.20	3000			10	1.4	<b>20</b>	2.9	40 *	5.7		
	90T3/4	10.0	2.20	2100			10	1.0	<b>20</b>	2.0	40 *	4.0		
	90T3/4 Δ	9.60	3.00	3000			10	1.0	<b>20</b>	2.1	40 *	4.2		
	100T2/4	13.6	3.00	2100					20	1.5	<b>40</b>	2.9	60 *1)	<b>4.4</b>
	100T2/4 Δ	12.7	4.00	3000					20	1.6	<b>40</b>	3.1	60 *1)	<b>4.7</b>
	100T5/4	18.2	4.00	2100					20	1.1	<b>40</b>	2.2	60 *1)	<b>3.3</b>
	100T5/4 Δ	17.5	5.50	3000					20	1.1	<b>40</b>	2.3	60 *1)	<b>3.4</b>

<b>Weight [kg]</b>	2.0	3.0	5.5	7.0	10
<b>J [10<sup>-3</sup> kgm<sup>2</sup>]</b>	0.015	0.045	0.153	0.45	0.86

**Braking torques printed in bold type:** Standard version

\* IP 66 brake not possible

<sup>1)</sup> Manual release not possible

### ⚠ Determining the brake torque

The selection of a standard motor-brake combination according to the overview above must be verified by careful planning! It is essential that the braking torque is specified according to the requirements of the application.

Among other things, the drive design is oriented to both the torque requirement of the application and the motor torque. If necessary, the braking torque must be reduced considerably so that the gear unit is not overloaded when large moving masses are braked.

### Holding brake • Working brake • Emergency stop brake

The differentiation between “holding brake”, “working brake” and “emergency stop brake” results from the type of application.

#### Holding brake

A holding brake is used to prevent the movement of a drive chain which is at a standstill or nearly at a standstill.

#### Working brake

As soon as a brake needs to produce significant frictional effort it is referred to as a working brake. When selecting the brake, the relevant frictional effort as well as the actuation frequency must be determined and taken into account.

#### Emergency stop brake

For the emergency stop brake function very large masses must be stopped once and the brake is subjected to correspondingly large energies.

In this case the brake must be selected according to the maximum permissible frictional effort of each braking action.

## Application-related examples for holding brake and working brake

A frequency inverter controls the acceleration and deceleration of the application. The mechanical spring-loaded brake is only applied after the application has come to a standstill.

### Holding brake

The brake is therefore only used for “holding” the application (parking position). It does not perform any friction work and thus no conditioning of friction surfaces.

Friction work is only transmitted in case of emergency stops or power cuts.

The geared motor is directly supplied by the local voltage supply. To slow down the application, the mechanical spring-loaded brake must generate a braking torque and thus performs friction work.

### Working brake

The continuous friction work ensures a conditioning of the friction pairings. The resulting friction heat must be efficiently dissipated.

The mechanical brake is also used for “holding” the application (parking position).

## Brake connection voltages

Brakes are available with the following coil voltages:  
**24 VDC, 180 VDC, 205 VDC**

Characteristic	Value	Comment
Maximum speed	6000 rpm	
Friction work per emergency stop	3000 J	Then regeneration by simple braking
Actuation frequency for 1500 J	100 switching cycles per hour	Then the maximum friction work decreases
Protection class	IP20	Brake is fully integrated into the motor
PWM control	Possible	

More information about the brake is available upon request.

Dimensioned drawing  
IEC B14 IE5+  
motor with brake

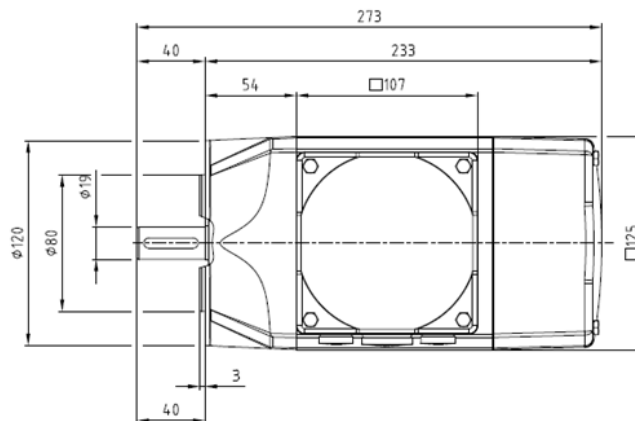

## Brake control

An inverter with appropriate rectifier is required to control the brakes.

A rectifier integrated in the terminal box of the motors is not available for IE5+ motors.

As an alternative, a rectifier in the switch cabinet can be used. NORD offers a rectifier: the **SK EBGR-1**.

For more technical information about the rectifier, please refer to the [NORD Homepage](#).



Rectifier  
SK EBGR-1



## Planning and commissioning guide for NORD synchronous motors (PMSM) with NORD frequency inverters

### General

Regarding the basic functionality, motors with efficiency class IE4 or IE5+ are synchronous motors, and are designed for operation with a frequency inverter. Due to their high efficiency, they offer energy saving advantages. From the efficiency point of view, the complete system must be considered.

- Frequency inverters have an efficiency of > 95%. By optimised processes, the use of inverters can offer energy related advantages to the extent that they oppose the power loss of the individual device by a multiple (e.g. speed control for pumps instead of using throttle valves).
- When selecting the gear units, the underlying operating factor ( $f_B$ ) as well as the usefulness of the motor-gear unit combination is important, especially when combining with high-efficiency synchronous motors.
- When designing and selecting drives, the requirements for overload operation must be taken into account, in particular for unventilated motors (TENV). NORD provides planning assistance for critical applications.

### NORD synchronous motors

Currently, NORD offers motors with efficiency classes IE4 and IE5+ within the 0.35 kW – 5.5 kW power range (71 – 100 size). The motors are self-ventilated or unventilated, and are basically available with all known motor options and gear unit combinations. NORD synchronous motors are equipped with permanent magnets in the rotor package. These are inserted into recesses (the so-called IPMSM: integrated permanent magnet synchronous motor) and therefore require less use of magnet materials compared to the SPMSM (surface permanent magnet synchronous motor).

A synchronous motor cannot be started and operated with mains voltage, but only with the frequency inverter. All NORD frequency inverters can operate NORD synchronous motors.

In principle, NORD synchronous motors can be operated with inverters from other manufacturers. Some competitor devices have been successfully tested with our motors. The customer is responsible for the successful commissioning. Furthermore, the motor performance or the achievement of efficiencies that comply with the IE4 classification depends on the inverter and its functionality and settings.

Synchronous motors from other manufacturers can be theoretically operated with the NORD inverter. This option must be checked beforehand and a test motor may be calibrated in the main production plant (consultation urgently required). NORD has already commissioned third-party motors with NORD inverters.

# NORD IE4/IE5 PLANNING INFORMATION



## NORD PMSMs are not servo motors

As synchronous motors, they do not have a load-dependent slip. The NORD motors are suitable for different nominal speeds:

1. 2,100 rpm with 140 Hz, 400 V Star (applies to the PMSM series with efficiency class IE5+)
2. 2,100 rpm with 70 Hz, 400 V Star and 230 V Delta
3. 3,000 rpm with 100 Hz and 400 V Delta

The motor is delta-connected and is theoretically operated with  $70 \text{ Hz} \times 1.71 = 121 \text{ Hz}$  (cf. 87 Hz characteristic curve with 50 Hz motors). As the 121 Hz operation produces loud noises (fan) and hampers the gear unit assignment, the 100 Hz, 400 V Delta type point is designated. This is not available for all NORD synchronous motors.

In addition to the selected operating points, the motor rating plate contains details on motor stator resistance  $R_S$ , stator inductances  $L_d$  and  $L_q$ , and the induction voltage value (UEMK). These details are required for the inverter programming.

## IE5 synchronous motor type code using the example of a 71N1/8

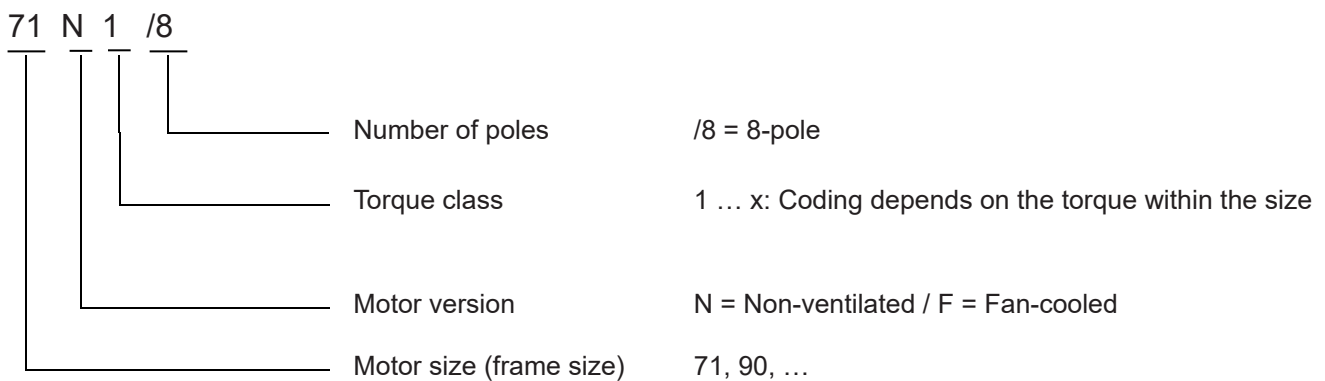

## IE4 synchronous motor type code using the example of an 80T1/4 (Note: IE5 nomenclature)

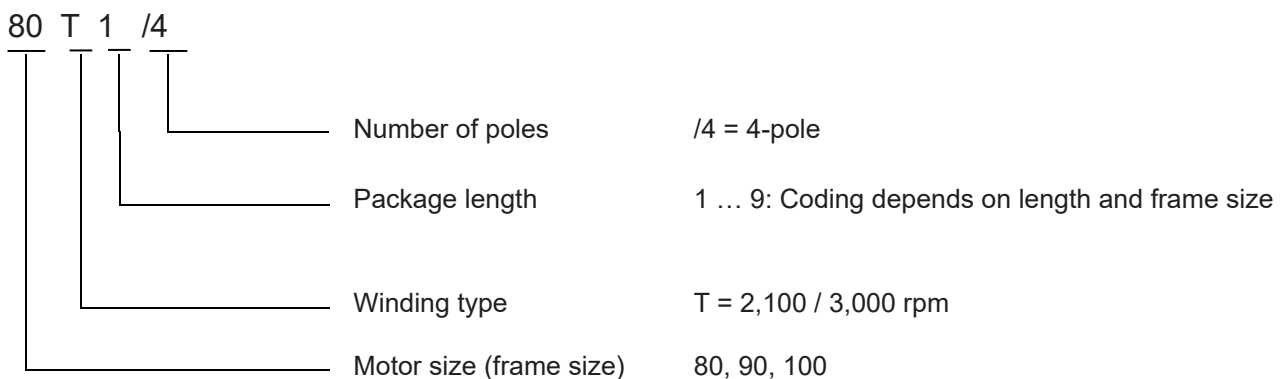

## Motor-inverter assignment

The following assignments of the motors to the respective frequency inverters apply to nominal operation. Overloads require planning and, if necessary, an adjustment of the inverter assignment.

Size	$M_N$ [Nm]	$P_N$ [kW]	$n_N$ [rpm]	$I$ [A]	$\eta$	$J$ [kgm <sup>2</sup> ]	$M$ [kg]	$M_{max}$ [Nm]	$K_T$ [Nm/A]	$K_E$ [mV/rpm]	FI assignment
71 N1/8	1.6	0.35	2100	0.76	89.1	0.00019	4.9	4.8	2.1	143	-370-340 -550-340
71 N2/8	3.2	0.7	2100	1.45	92.5	0.00038	6.0	9.6	2.2	144	-750-340
71 N3/8	4.8	1.1	2100	2.14	93.6	0.00057	7.0	14.4	2.2	144	-111-340-
80T1/4	5.0	1.1	2100	2.07	90.5	0.0011	8.0	14.4	2.5	154	-111-123- -111-323- -111-340-
80T1/4 HM	3.41	0.75	2100	1.46	90.5	0.0011	7.8	14.4	2.3	154	-111-123- -111-323- -111-340-
80T1/4 Δ	4.8	1.5	3000	3.44	90.4	0.0011	8.0	14.4	1.4	89	-151-340-
90T1/4	6.8	1.5	2100	2.82	89.9	0.0019	10.0	21.0	2.4	156	-151-323- -151-340-
90T1/4 Δ	7.0	2.2	3000	5.09	89.6	0.0019	10.0	21.0	1.4	90	-221-340-
90T3/4	10	2.2	2100	4.13	90.5	0.0024	12.0	29.0	2.4	158	-221-323- -221-340-
90T3/4 HM	5.0	1.1	2100	2.08	92.7	0.0024	11.6	28.3	2.4	156	-151-323- -151-340-
90T3/4 Δ	9.5	3.0	3000	6.84	92.3	0.0024	12.0	29.0	1.4	91	-301-340-
100T2/4	13.6	3.0	2100	5.4	91.4	0.00416	18.0	42.0	2.6	161	-301-323- -301-340-
100T2/4 Δ	12.7	4.0	3000	8.9	92.1	0.0046	18.0	42.0	1.5	93	-401-340-
100T5/4	18.2	4.0	2100	7.1	92.1	0.0060	21.0	57.0	2.6	165	-401-323- -401-340-
100T5/4 HM	10.0	2.2	2100	4.16	91.0	0.0060	20.2	53.5	2.4	165	-301-323- -301-340-
100T5/4 Δ	17.5	5.5	3000	11.9	92.2	0.0060	21.0	57.0	1.5	95	-551-340-

## Information

### Motor power vs. inverter power

The inverter → motor assignment is primarily made according to the power. Due to the characteristic curves, in some cases a NORD inverter with a higher power must be assigned to the motor:

The inverter assignment is made for remote inverters (e.g. NORDAC PRO in the control cabinet or NORDAC LINK).

Overloads or dynamic start/stop applications may require an inverter assignment with a higher power. For a 1:1 assignment of the motor to the inverter, up to 2x the nominal torque is possible. In theory, the motor itself can provide up to 3x the nominal torque (when starting and within the limited speed range).

Continuous overload with factor of 1.4 is possible above 10 Hz (this does not apply to unventilated PMSMs).

### Operating modes

Compared to asynchronous motors, synchronous motor operation shows the following relevant differences:

- **No mains operation**

NORD synchronous motors can only be operated with an inverter.

- **Field weakening range**

NORD synchronous motors cannot be operated within the field weakening range, or only to a very limited extent. During rotation, the permanent magnets in the rotor induce voltage in the stator that counteracts the terminal voltage. The induced voltage is in proportion to the motor speed, and reduces the current-driving terminal voltage. This decreases the available motor torque. Furthermore, there is a danger that due to high motor speeds high voltages may damage the inverter, e.g. in case of falling loads of lifting equipment.

- **Inverter functions**

Certain inverter functions are not available, e.g. DC braking.

**Inverter operation supports the following control types:**

- **VFC open-loop mode**

- Applications with linear or quadratic load characteristic curve
- Low dynamics
- Very limited maximum torques

- **CFC open-loop mode**

- Applications with constant, linear or quadratic load torques
- Moderate dynamics
- Limited maximum torques

- **CFC closed-loop mode**

- All types of application, including lifting equipment
- High dynamics
- Speed-independent maximum torque

**The operating mode has an impact on the drive performance:**

- Dynamics or acceleration times
- Available maximum torque depending on the speed

## Commissioning

1. Check the inverter selection with regard to motor assignment.
2. Check the inverter selection with regard to operating mode/encoders.
3. Check the motor circuit with regard to the characteristic curve and (inverter) mains voltage.
4. Inverter and motor connection as known.
5. Observe the safety information according to the operating instructions and work instructions.
6. Connect the mains supply.
7. Inverter parameterisation can be carried out with:
  - SimpleBox,
  - ParameterBox (Firmware version V4.6R1 or higher, or in ControlBox mode)
  - NORDCON (version 2.5 or higher, or ControlBox mode)
  - NORDAC ACCESS BT
8. In P200 the relevant NORD synchronous motor can be selected from the list. This ensures that the motor data are set correctly. A stator resistance measurement P220 = 1 is recommended.
9. Select the control method (P300):

### VFC open-loop mode (pumps, fans), P300 = 0

#### Low dynamics

- From starting up to the frequency specified by P247 (switchover frequency vfc PMSM), a current is applied that decreases linearly as the frequency increases in order to force the rotor to follow (the usual setting is 25% of the nominal frequency). The current magnitude can be influenced via P210 (static boost) (→ low starting torques = P210 < 100 %).
- No control parameters need to be set, but the precise motor data is required, in particular RS, L and UEMK.
- For stable operation, a suitable oscillation damping is necessary (P245) that quickly increases or decreases the frequency for dynamic load changes.
- When starting, the motor may briefly rotate in the opposite direction.

### CFC open-loop mode, P300 = 2

#### Moderate dynamics

- From 0 – 10% of the synchronous speed, operation is in VFC open-loop mode. In the hysteresis range, the current falls to the value of P209 (usually 0), after which the speed is determined from the current and the operating behaviour is improved by means of speed control.
- Control parameters can be set, but the precise motor data is required, in particular RS, L and UEMK.

### CFC closed-loop mode, P300 = 1

#### High dynamics

- Slip error monitoring required P337 + P338
- Setting of the current and speed controller required

### Possible encoder systems

#### Incremental encoder with zero track (NORDAC FLEX, NORDAC LINK)

- Connection of the zero track to digital input 1.
- Setting P420[ 01] = 42/43 (see relevant manual).
- A method of determining the initial rotor position is required in order to determine operation until the first zero point is passed (see below). The zero pulse corrects the error tolerances of the zero point determination method.
- If the incremental encoder is not aligned or has been misaligned due to an impact or removal of the motor, the zero track of the incremental encoder must be aligned to the rotor position. For this, an offset is set in P334. This does not apply to IE5 PMSMs. Here, the zero track is factory-set in the encoder.
- The activation of the slip error monitoring is mandatory (P327/P328).
- Due to the incremental measuring method, it is advisable to reference the drive at frequent intervals. If P420[ 01] = 43 is used, this can be done by resetting the voltage. With P420[ 01] = 42, it is sufficient to clear the enabling. After a slip error message, this is done automatically.

#### Incremental encoder without zero track

- A method of determining the initial rotor position is required, (see below); electrically, the measurement precision is only approx.  $\pm 3 - 10^\circ$ ; this results in a somewhat limited performance (unfavourable current-torque ratio).
- The activation of the slip error monitoring is mandatory (P327/P328).
- Due to the incremental measuring method, it is advisable to reference the drive at frequent intervals. This can be done by resetting the voltage. After a slip error message, this is done automatically.

#### Absolute/incremental combination encoders

- Absolute/incremental encoders do not require determination of the initial position (due to the absolute signal). The encoder is adjusted by NORD prior to delivery of the geared motor and does not require an offset determination.
- The activation of the slip error monitoring is mandatory (P327/P328).

### Determination of the initial rotor position

With incremental encoders, determination of the initial rotor position is required each time that the mains voltage is switched on or after certain inverter errors.

#### a. By the test signal method (P330 = 1)

Determination of the rotor position by test measurement (duration approx. 1 second). With P212, the current used for measurement can be amplified in order to achieve a better result under unfavourable conditions.

#### b. By the dwell method (P330 = 0, voltage-controlled)

The voltage forces the rotor into the zero position and therefore aligns the motor. This method is only possible for horizontal applications, e.g. for torque-free drive units without motor brake (**Caution:** The shaft turns during the movement).

The information in the relevant manuals must be observed.

Reference to document AG 0101 is recommended for setting and optimising the controller.

## NORD IE5+ Synchronous motors

- are not ventilated by default
- Cooling type IC410 according to EN 60034-6

### Overview of cooling types:

Designation		English short form (NEMA)
IC410	Without fan	TENV
IC411	Self-ventilated	TEFC
IC416	Externally ventilated	TEBC

## Vibration level A according to DIN EN 60034-14

NORD synchronous motors are designed according to vibration level A.

## Cable glands

Type	Dimensions
71	1 x M25 x 1.5 2 x M16 x 1.5

## Permissible radial and axial forces for IEC / NEMA motors

The listed values apply to a calculated bearing service life of  $L_n = 20,000$  h at 140 Hz operation for an 8-pole motor.

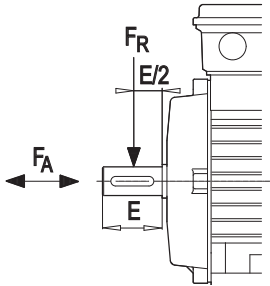

$F_R$  = Permissible radial force at  $F_A = 0$

$F_A$  = Permissible axial force at  $F_R = 0$

### Permissible radial and axial forces

Type	$F_R$ [N]	$F_A$ [N]
71	530	480

## Bearings and shaft seals

NORD motors have lifelong lubricated roller bearings. The B side bearing is implemented as a fixed bearing.

Greased radial shaft seals without springs are used on the A and B sides.

Oil-tight motors with various flanges for direct mounting onto the gear unit are available on request

**Refer to the operating and maintenance instruction B1091 for roller bearing replacement.**

Type	A bearing	B bearing (fixed bearing)
71	6204.2Z	6204.2Z

## Protection class according to DIN EN 60034-5

Protection against contact with moving and electrically live components as well as entry of solid foreign bodies, dust and water. The protection class is stated by the letters IP (International Protection) and two code numbers. (e.g. IP55).

1st code number	Protection class	
	Brief description	Explanation of standard IEC60034-5
5	Protection against touching, foreign bodies and dust	Complete protection against contact; dust cannot enter in harmful quantities.
6	Protection against touching, foreign bodies and dust	Complete protection against touching. Dust cannot enter
2nd code number	Brief description	Explanation
5	Protection against water	Protection against water from all directions Water cannot enter in harmful quantities.
6	Protection against water	Protection against heavy seas and strong water jets from all directions Water cannot enter in harmful quantities.
9	Protection against water	Protection against water for high pressure/steam cleaning



---

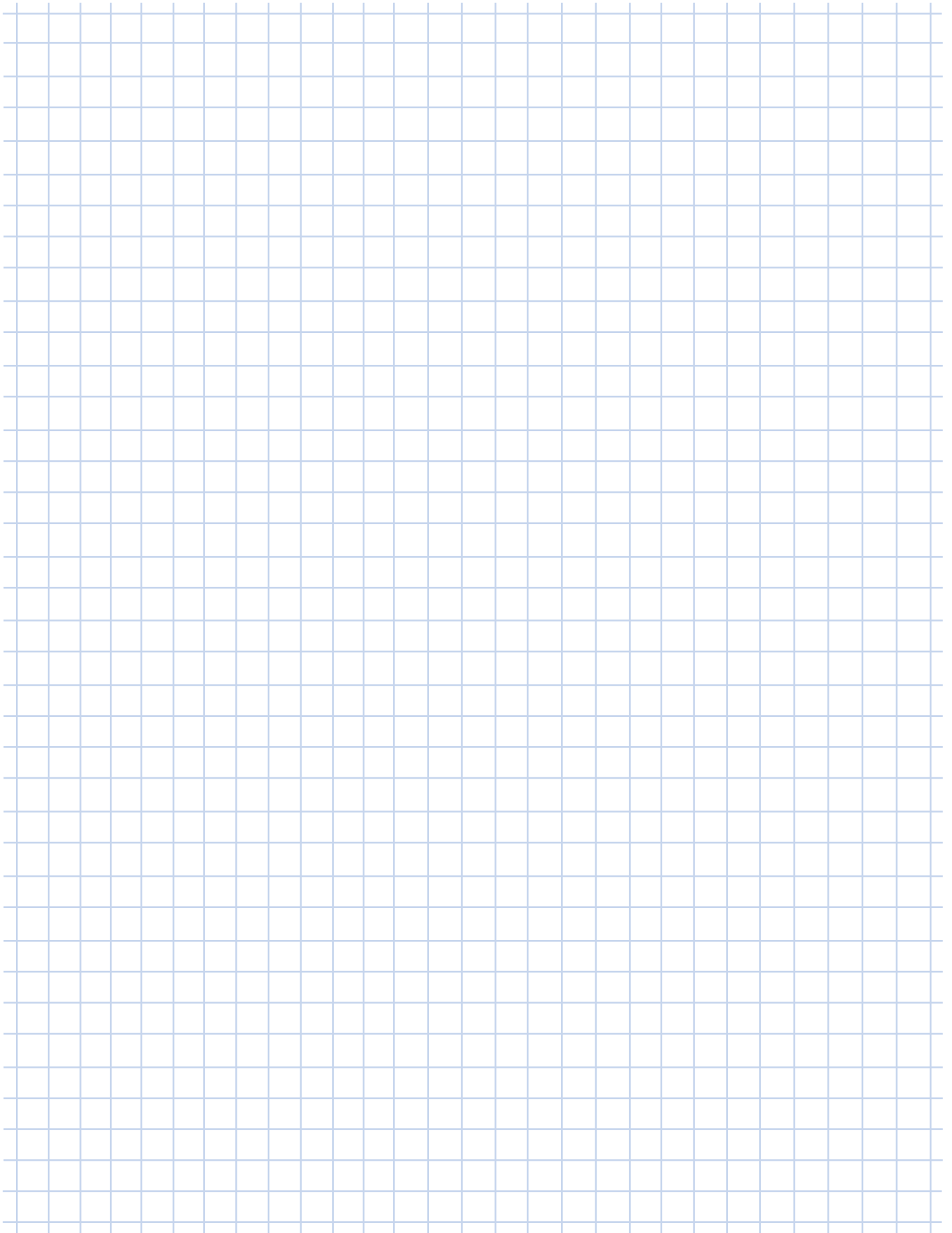

### 71 N1/8

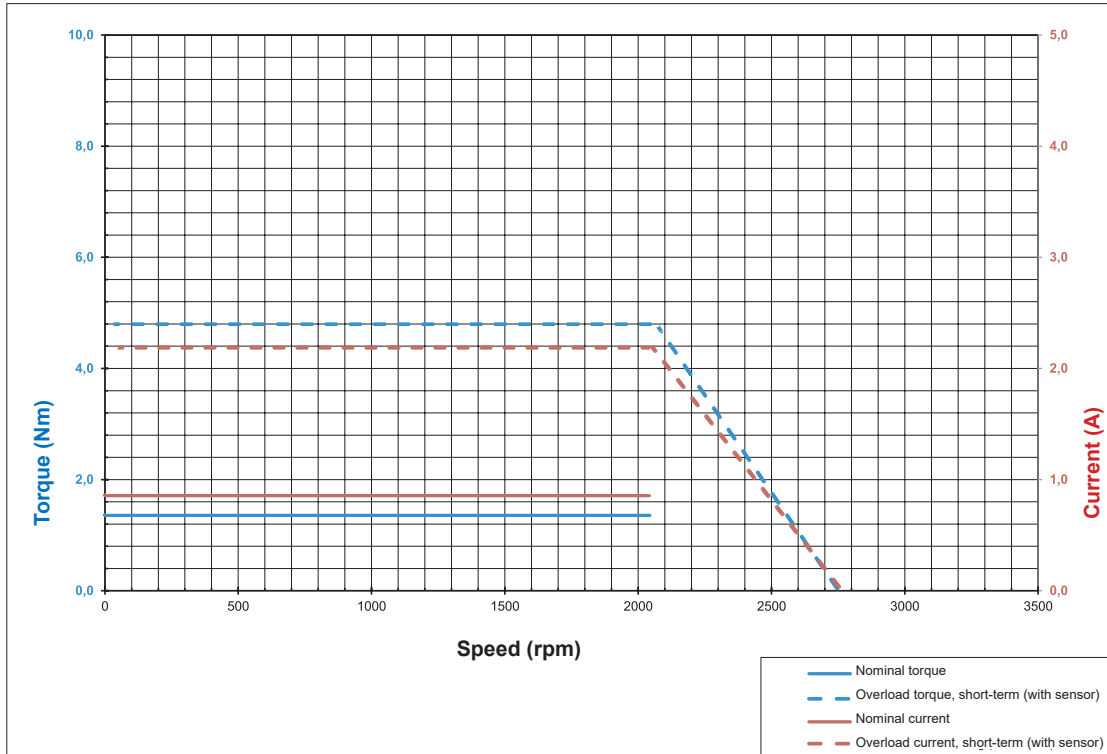

### 71 N2/8

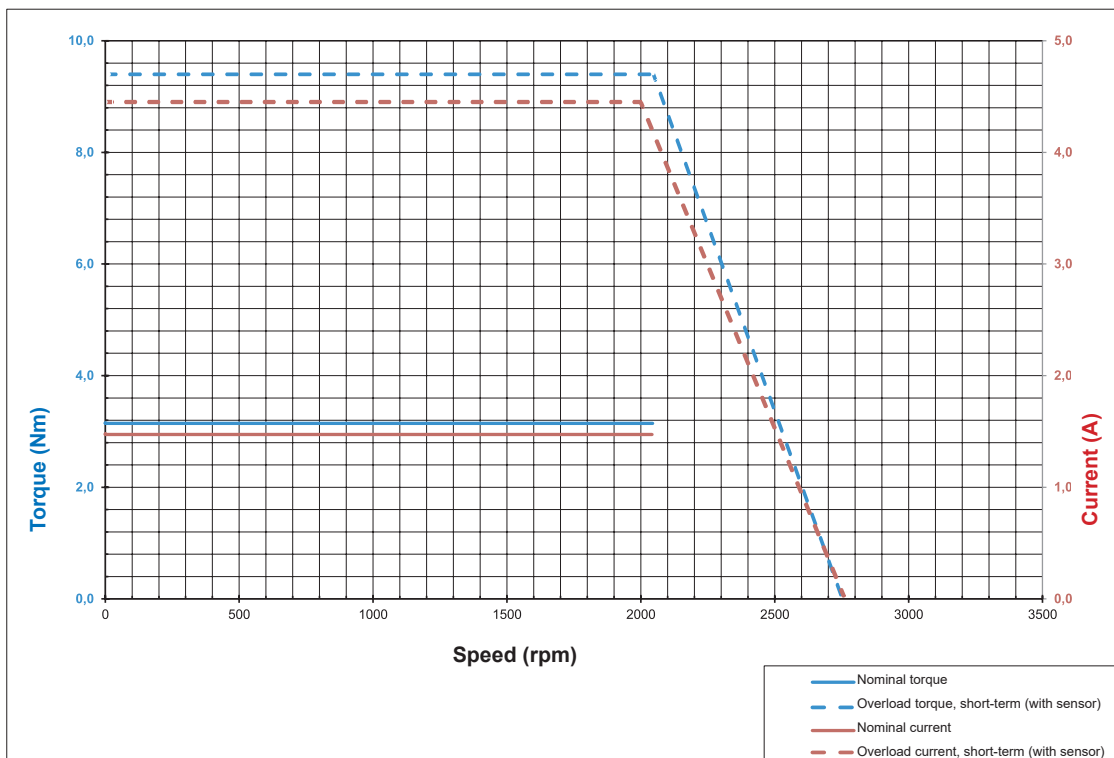

**71 N3/8**

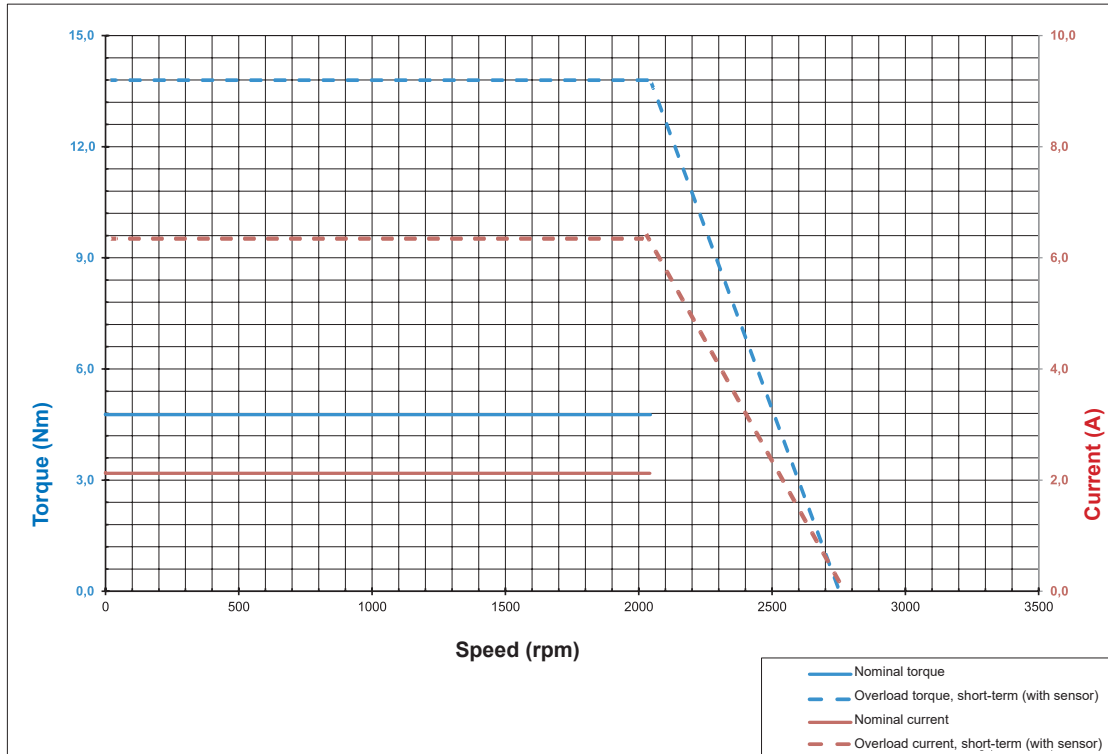

### 80 T1/4 Self-ventilated

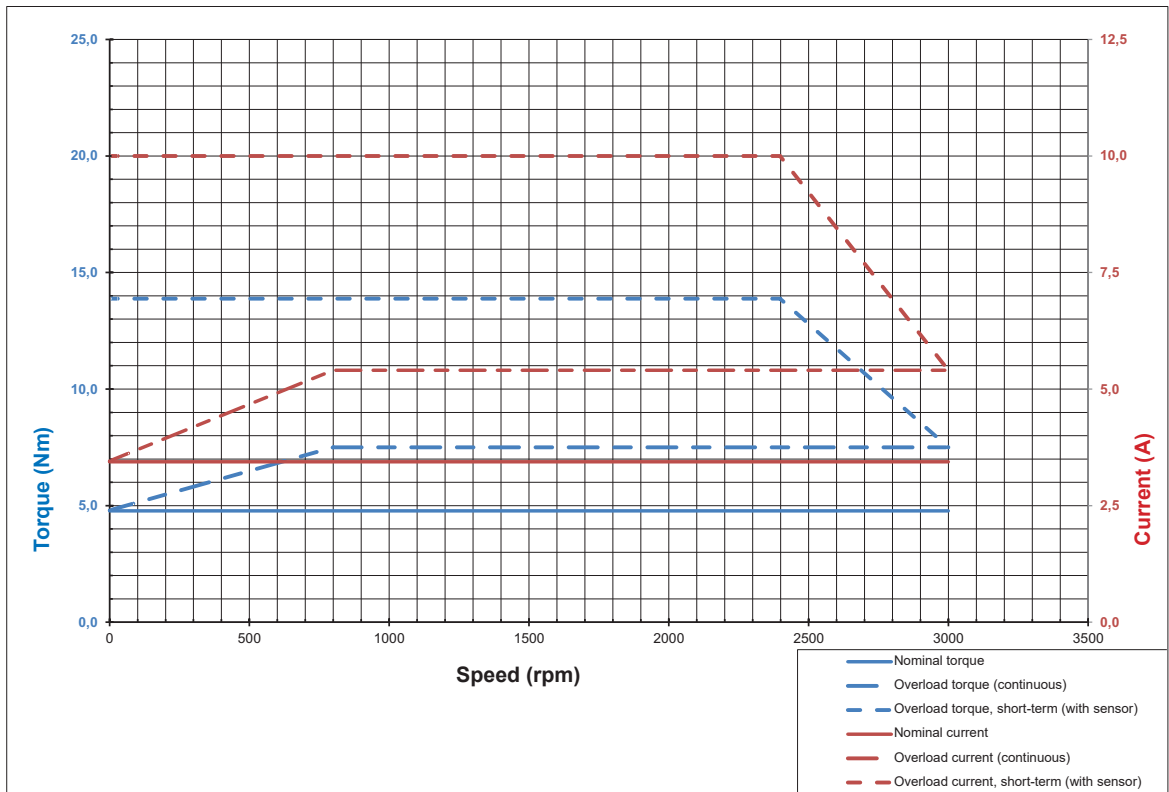

### 80 T1/4D

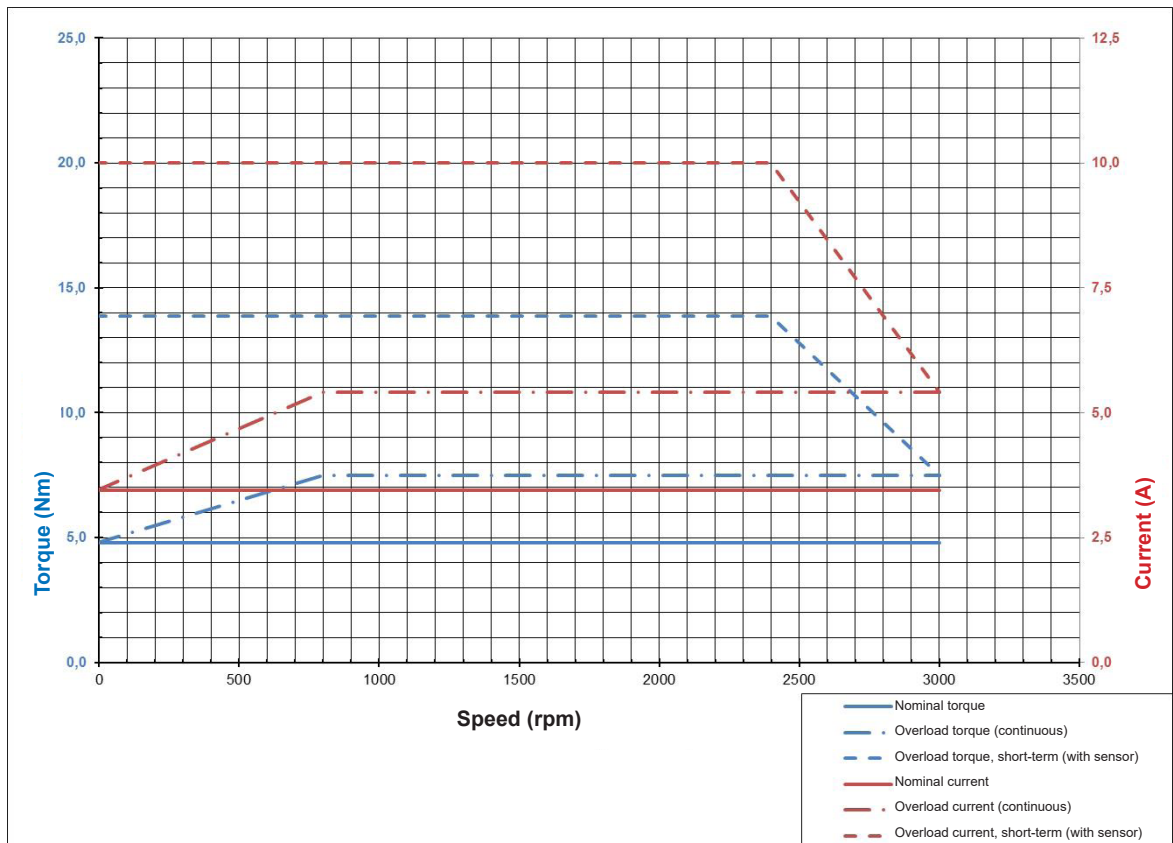

**90 T1/4**

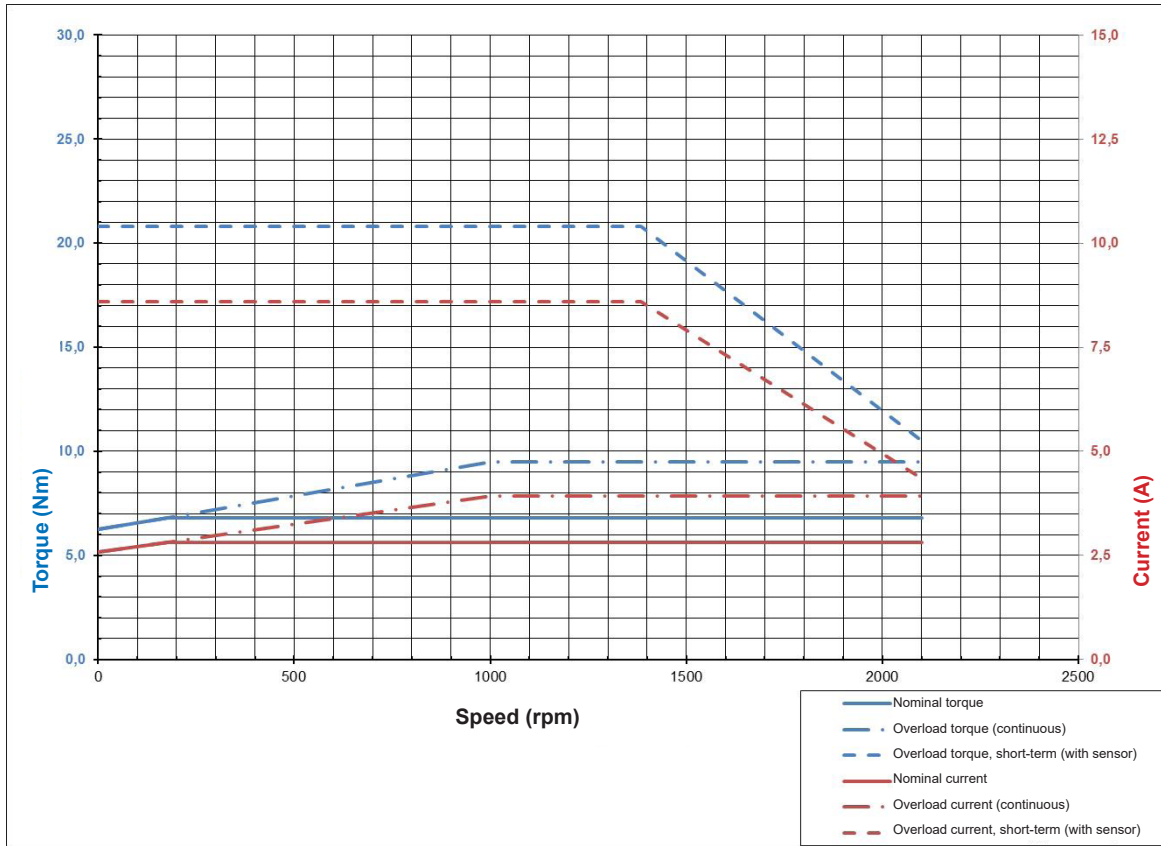

**90 T1/4D**

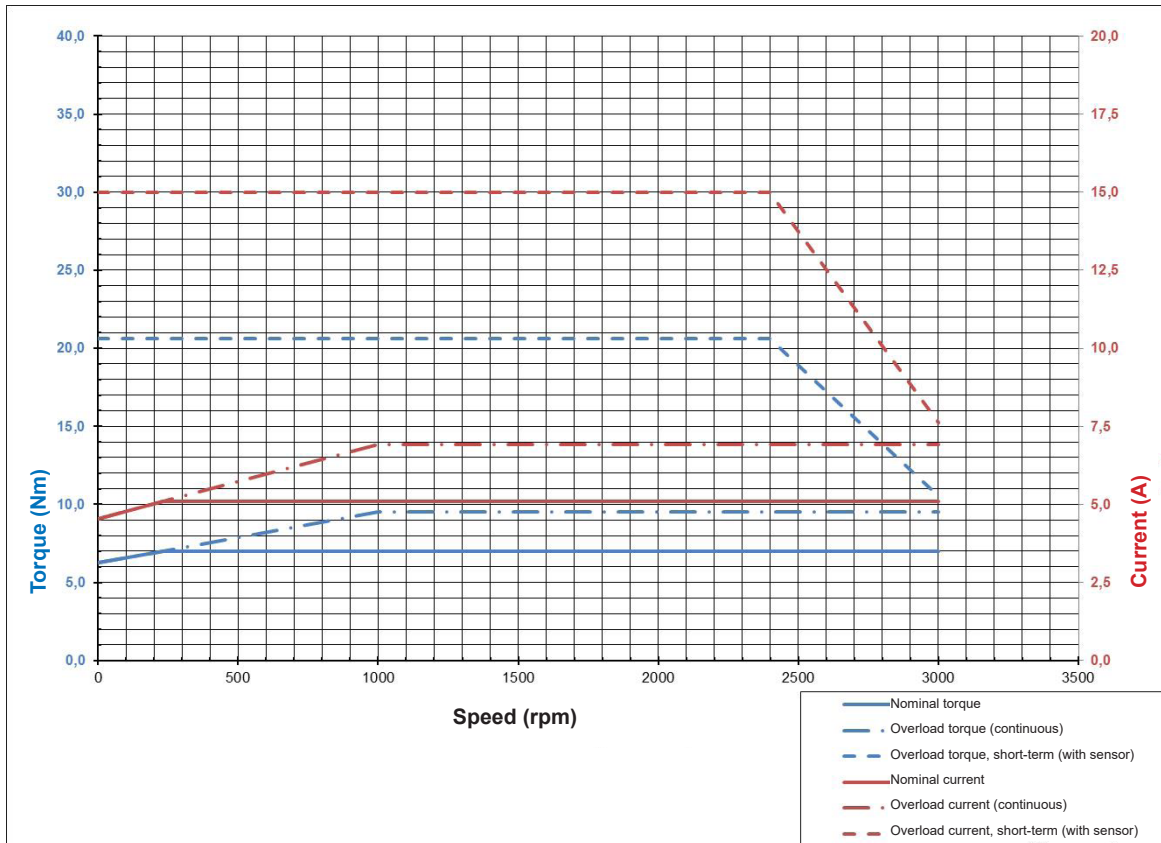

### 90 T3/4

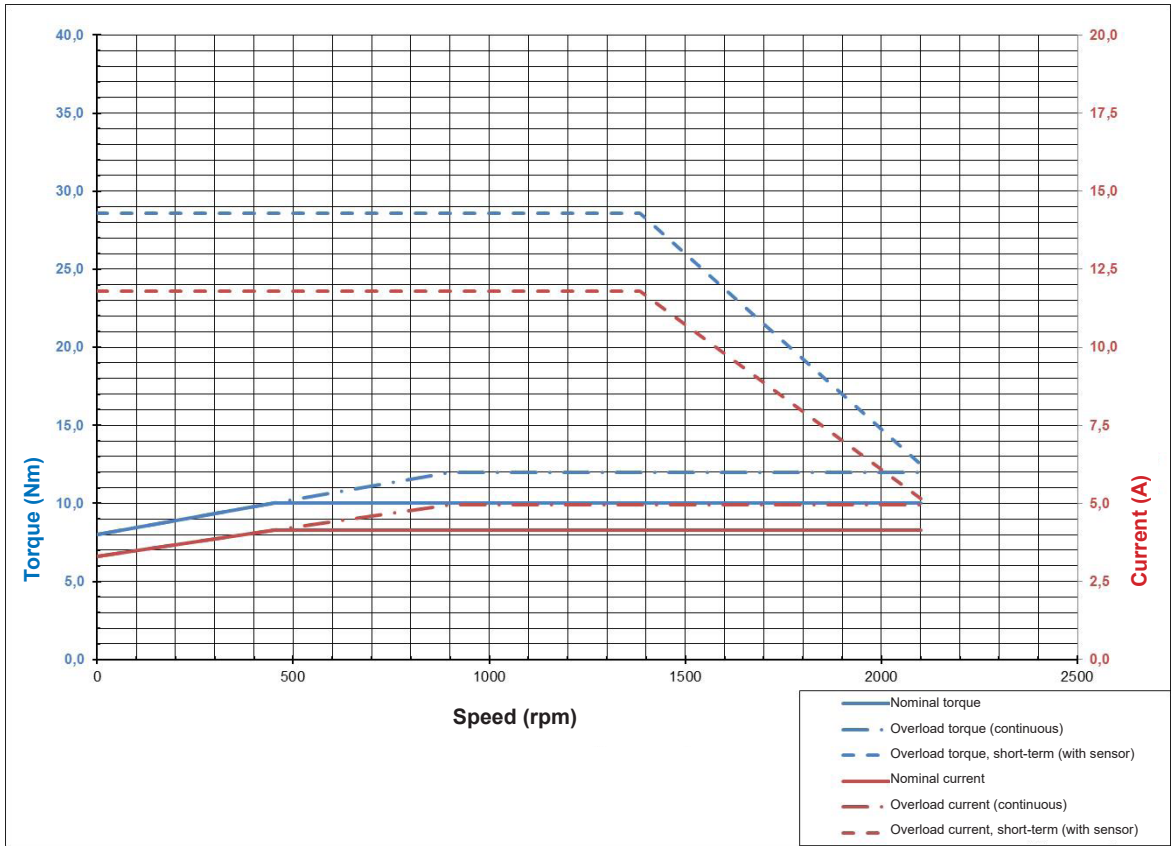

### 90 T3/4D

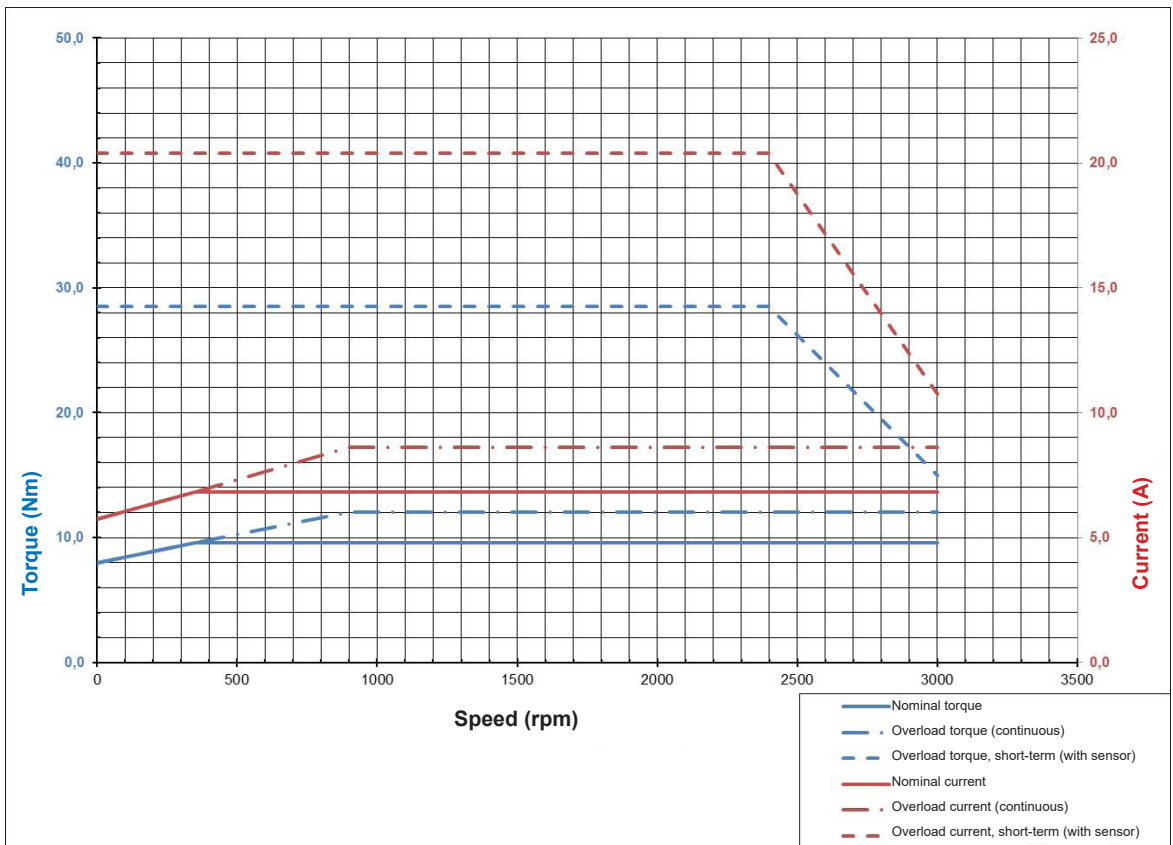

## 100 T2/4

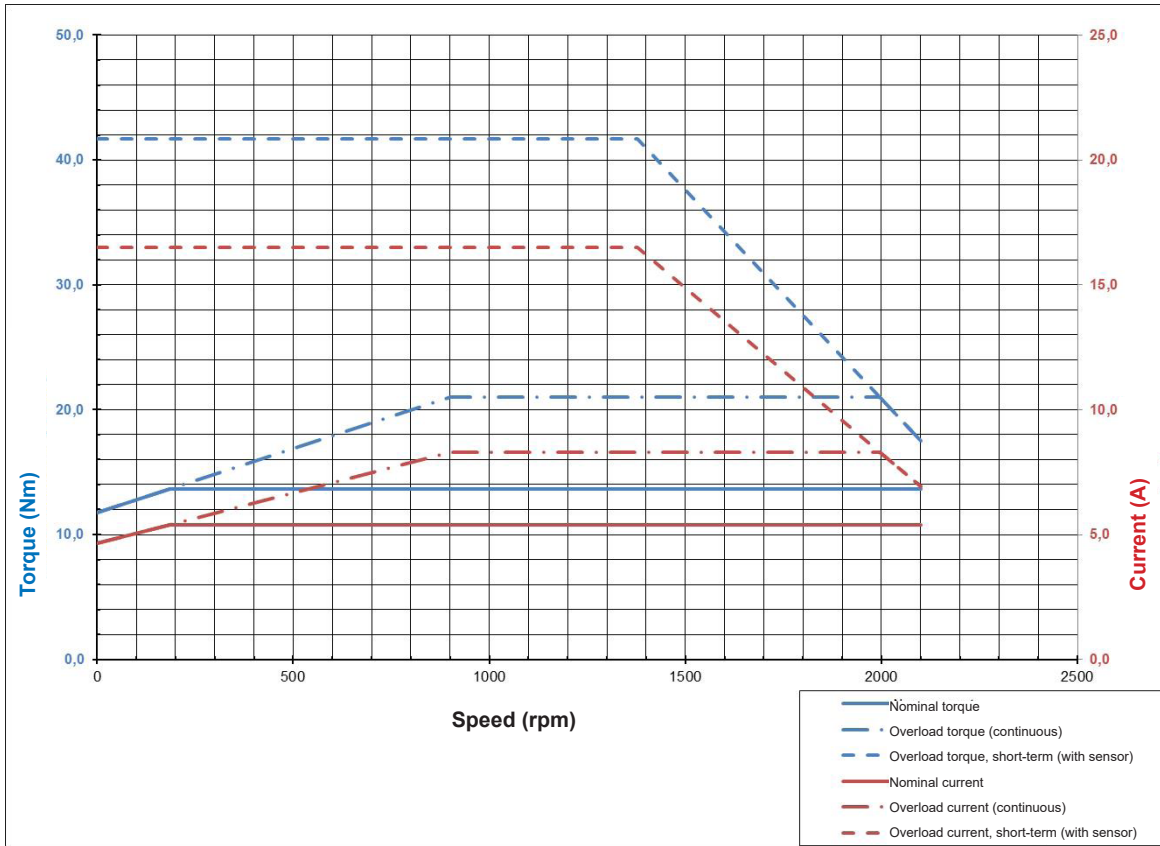

## 100 T2/4D

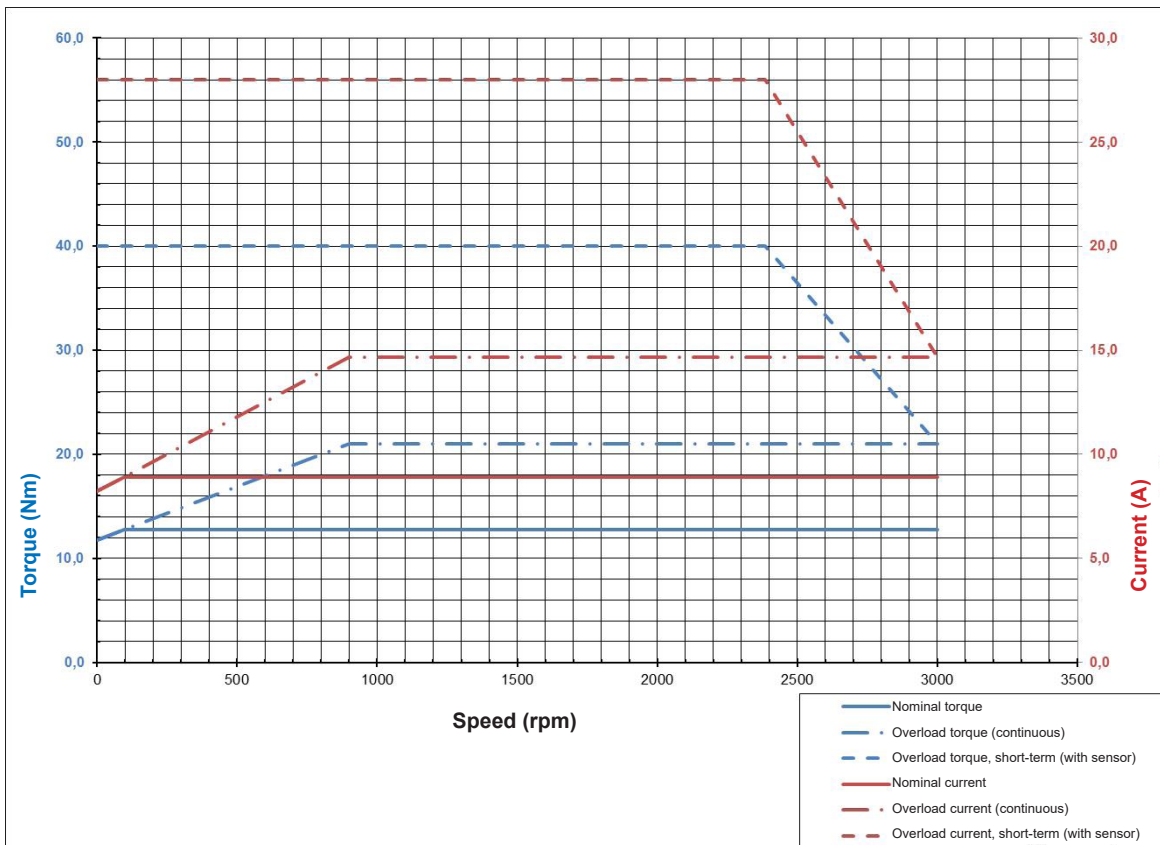

### 100 T5/4

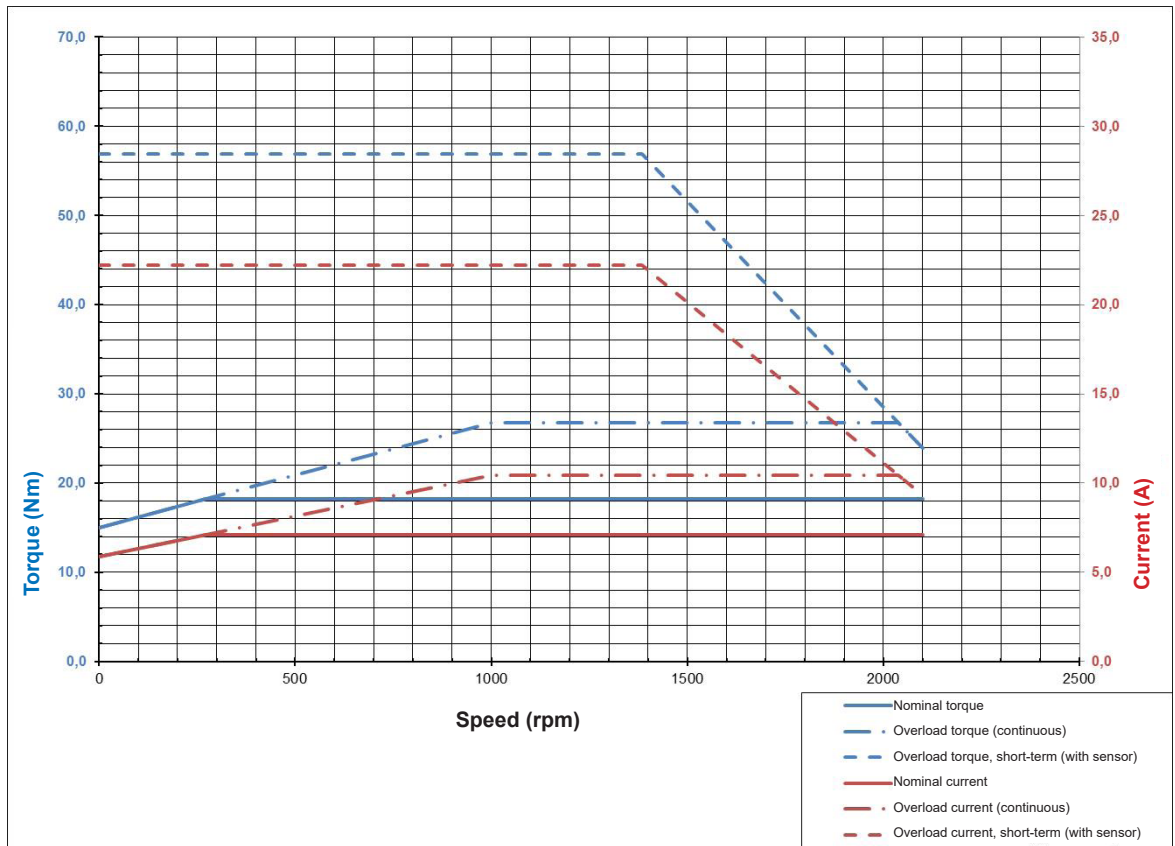

### 100 T5/4D

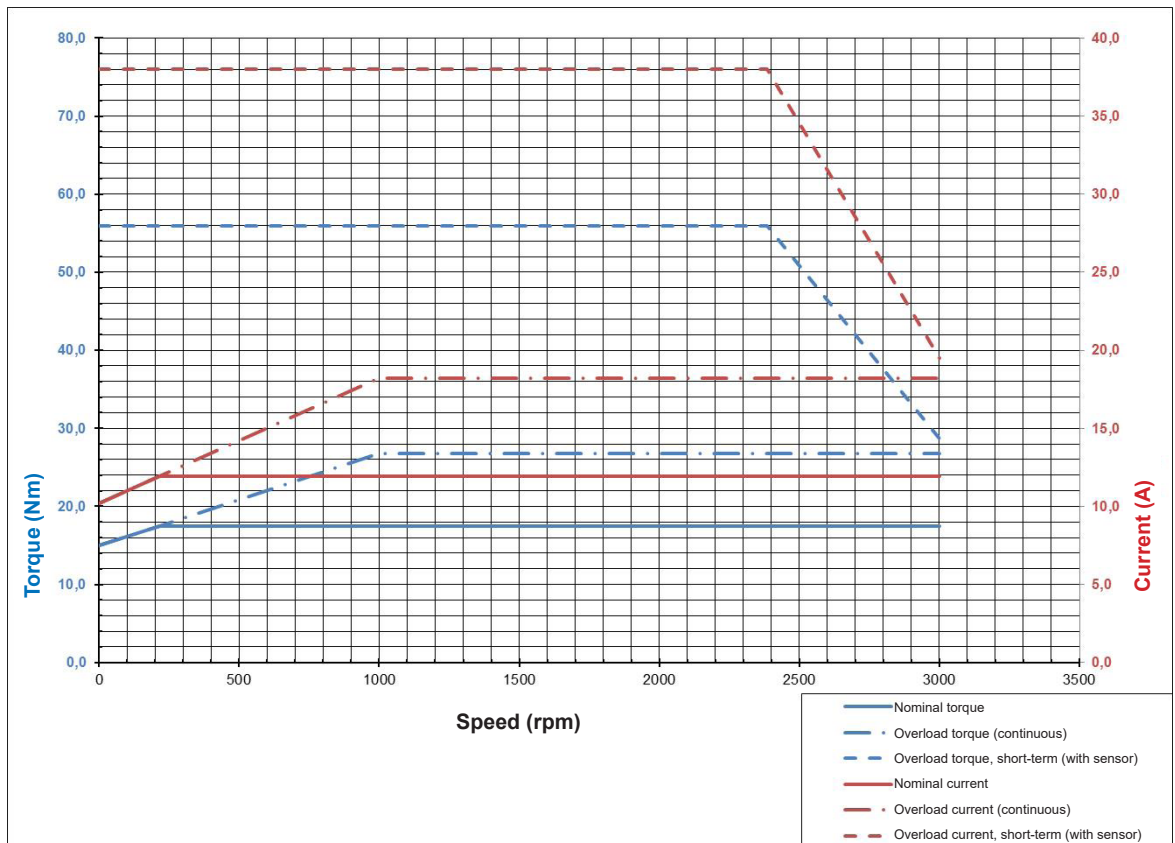



**80 T1/4 HM**

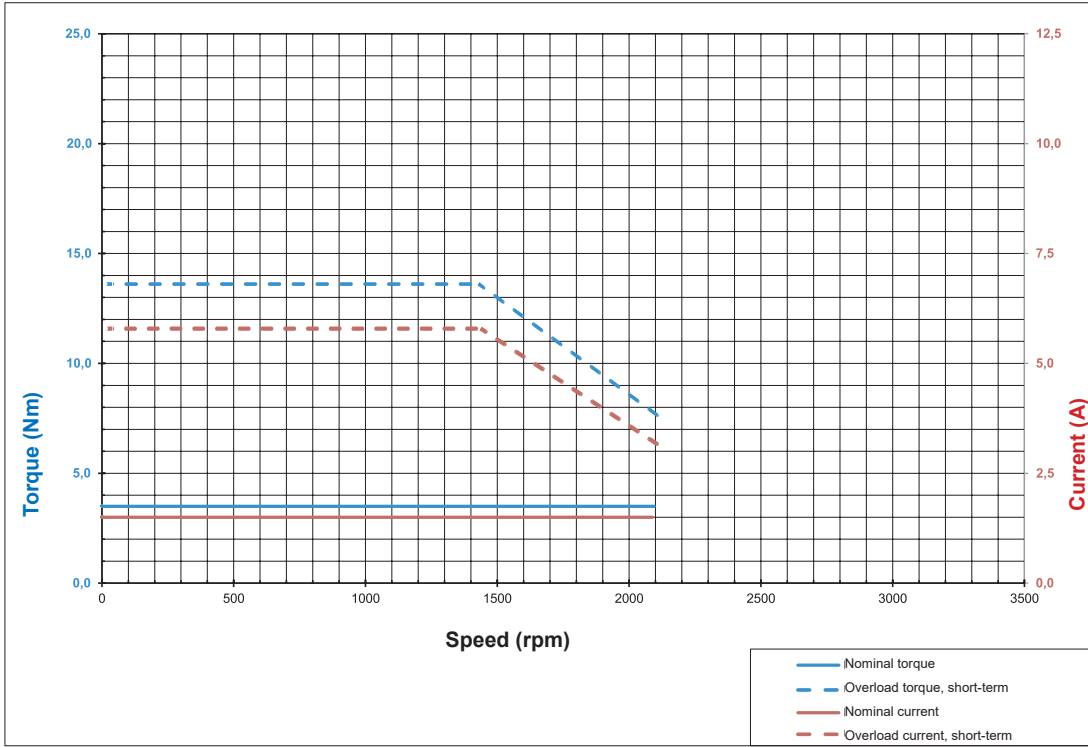

**90 T3/4 HM**

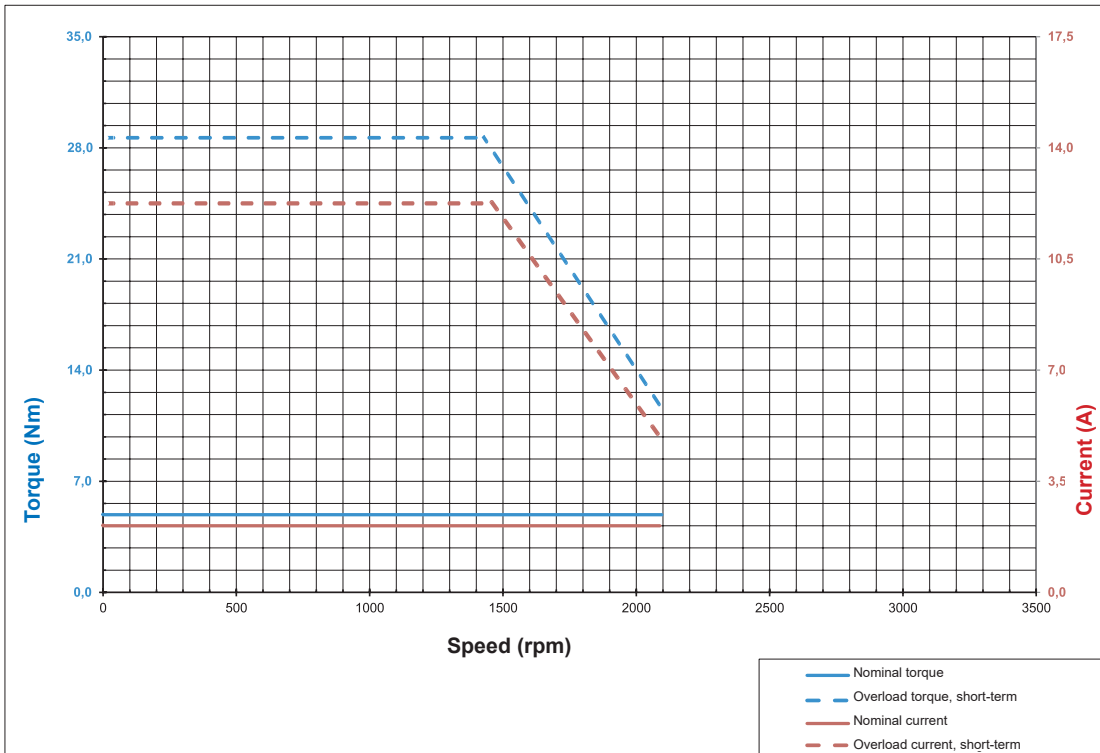

## 100 T5/4 HM

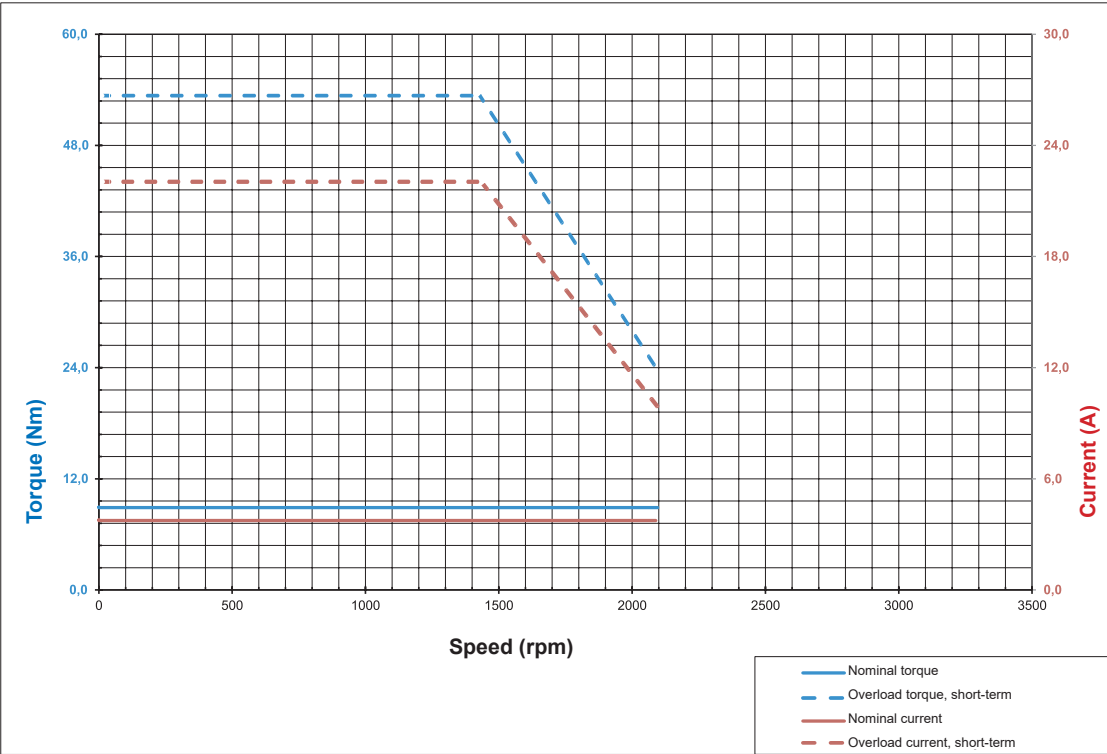

---

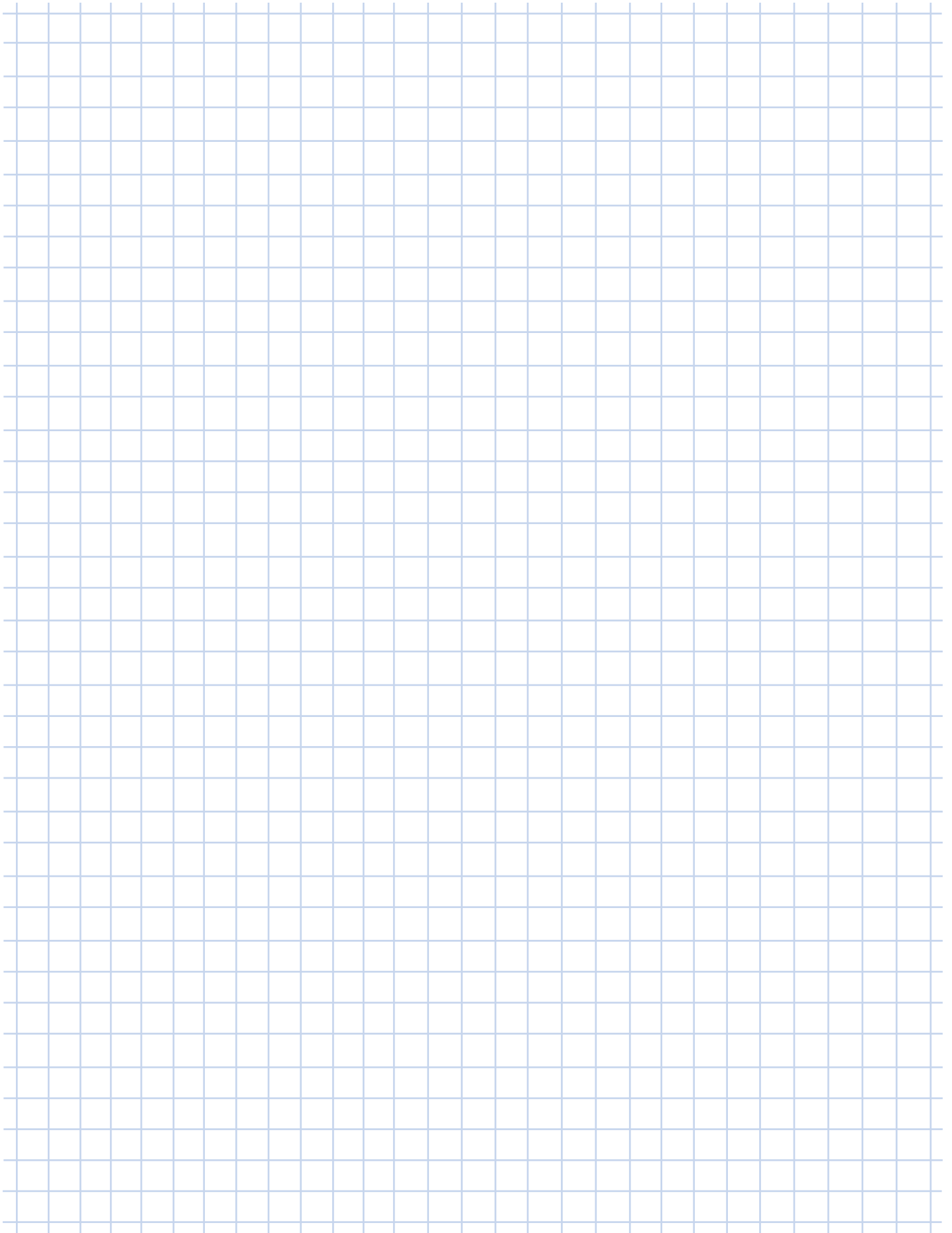

# NORD IE5 B5



71Nx/8

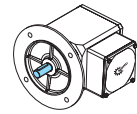
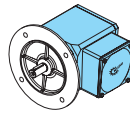
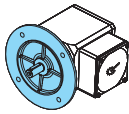
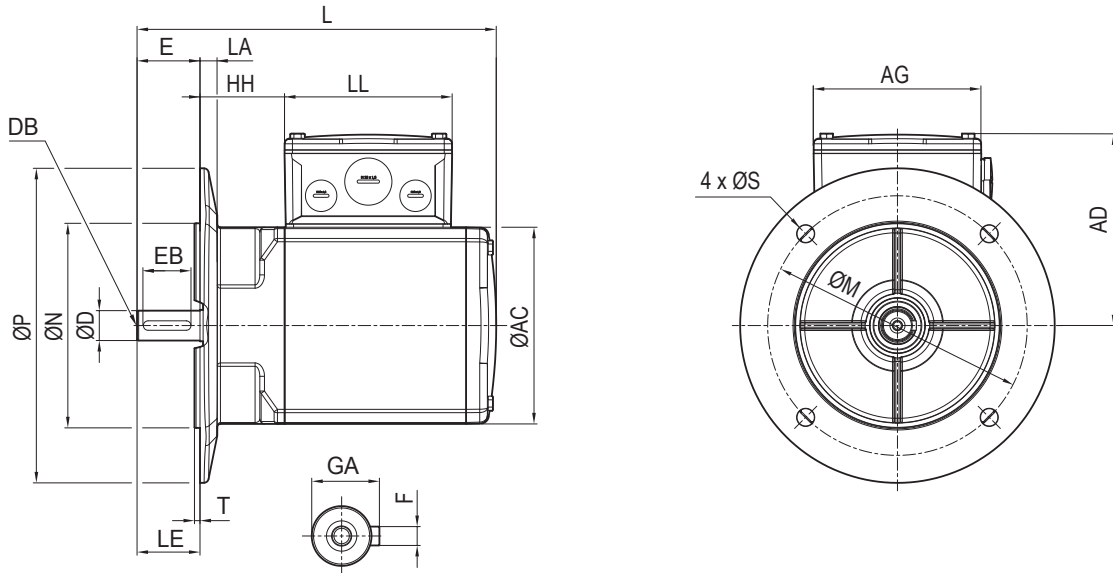

Type	LA	M	N	P	S	D	AC	AD	AG	HH	L	LE	LL	D	DB	E	EB	F	GA
71Nx/8	11	165	130	200	11	4.0	125	121	105	55	228	40	105	19	M6	40	32	6	21.5

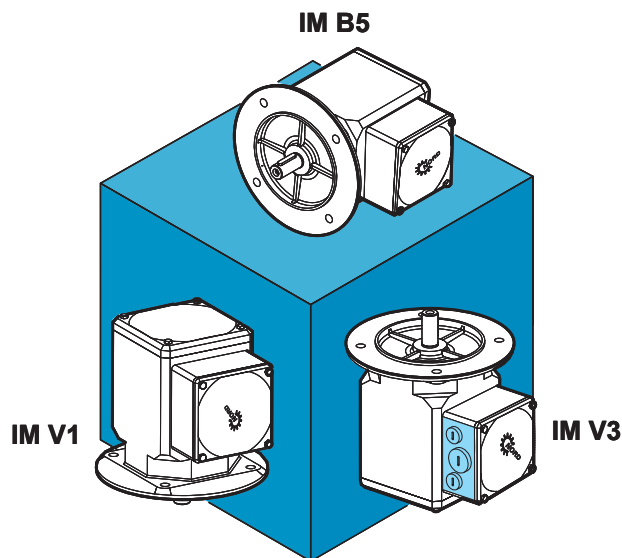



71Nx/8

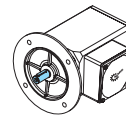
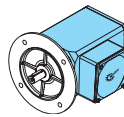
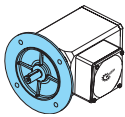
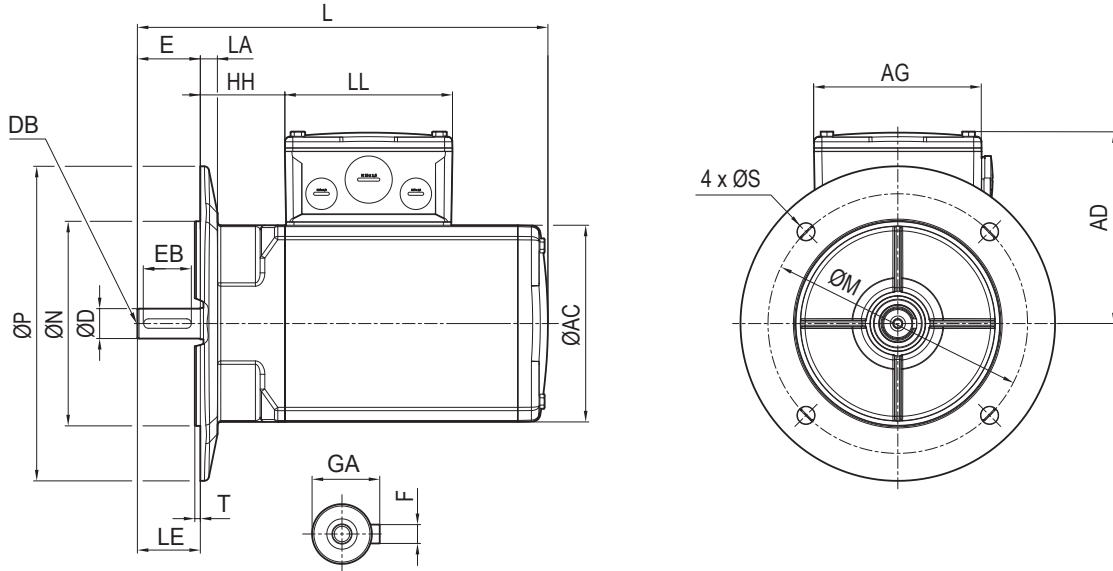

Type	LA	M	N	P	S	D	AC	AD	AG	HH	L	LE	LL	D	DB	E	EB	F	GA
71Nx/8	11	165	130	200	11	4.0	125	121	105	55	274	40	105	19	M6	40	32	6	21.5

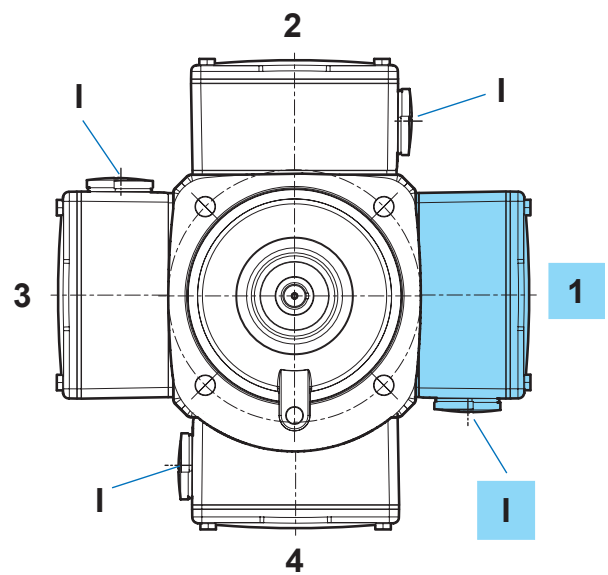
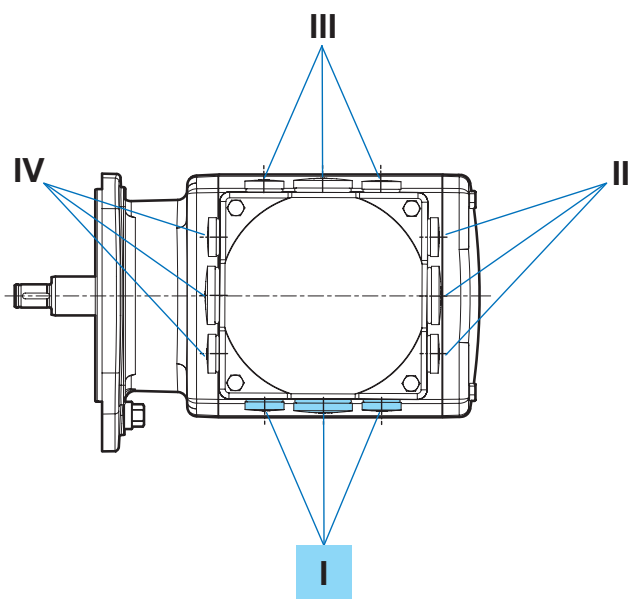

# NORD IE5 B14



## 71Nx/8

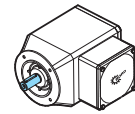
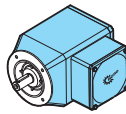
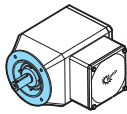
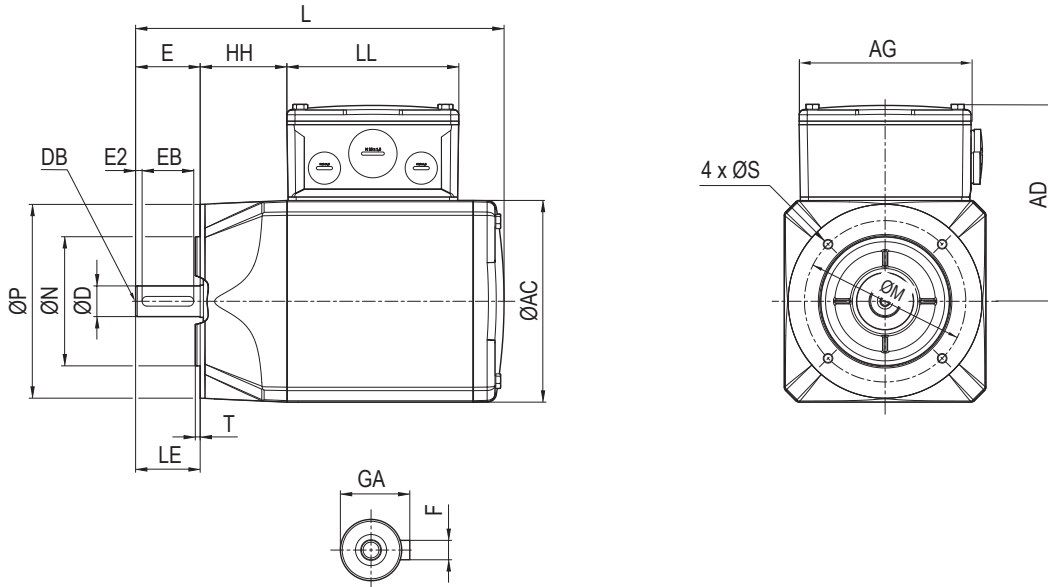

Type	M	N	P	S	D	AC	AD	AG	HH	L	LE	LL	D	DB	E	EB	F	GA
71Nx/8	100	80	120	M6x15	3.0	125	121	105	55	228	40	105	19	M6	40	32	6	21.5

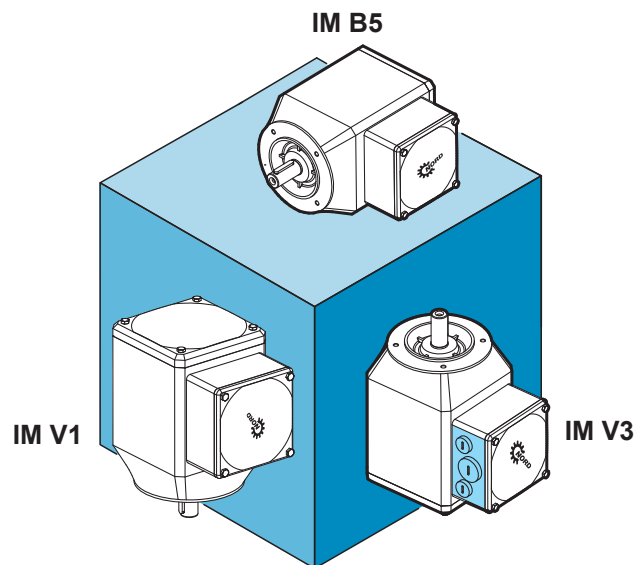



71Nx/8

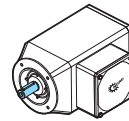
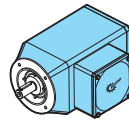
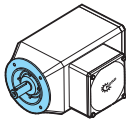
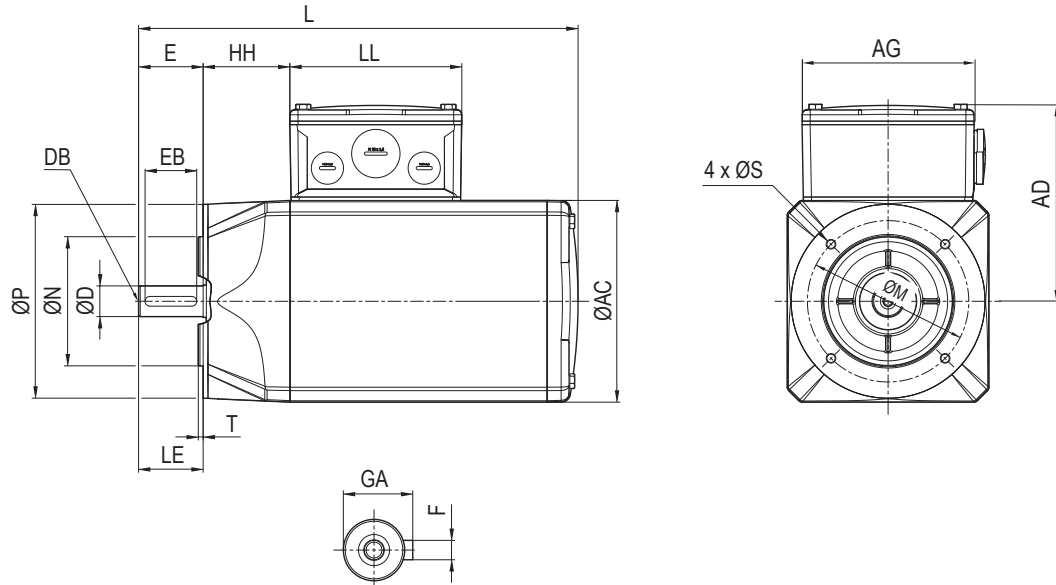

Type	M	N	P	S	D	AC	AD	AG	HH	L	LE	LL	D	DB	E	EB	F	GA
71Nx/8	100	80	120	M6x15	3.0	125	121	105	55	274	40	105	19	M6	40	32	6	21.5

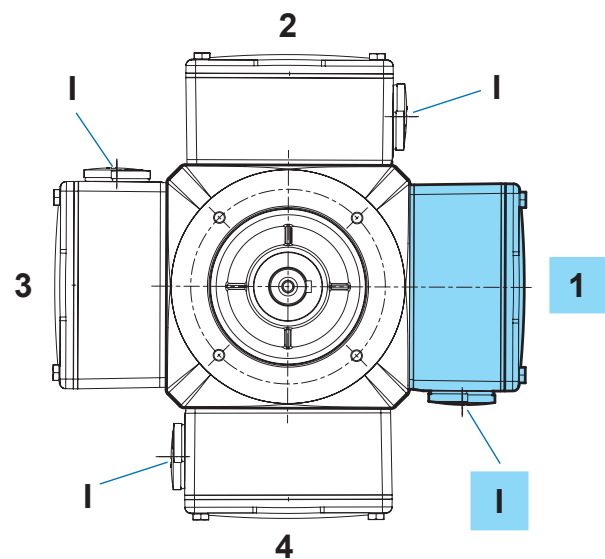
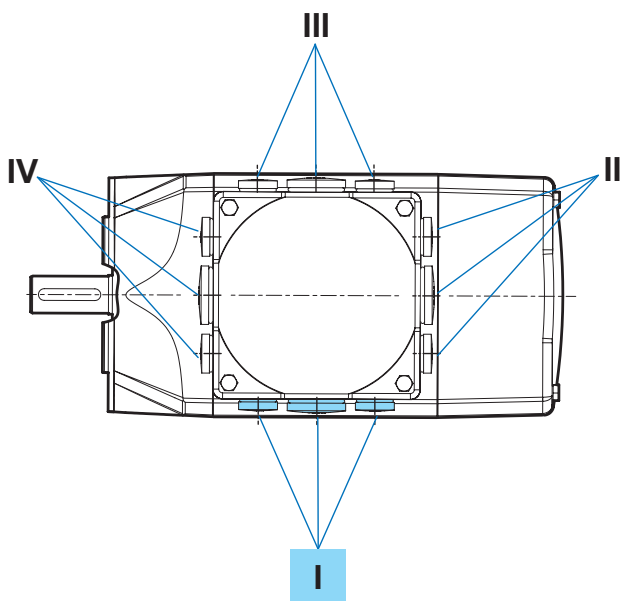



## 71Nx/8

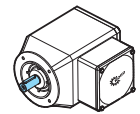
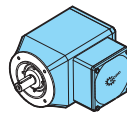
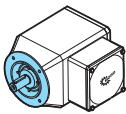
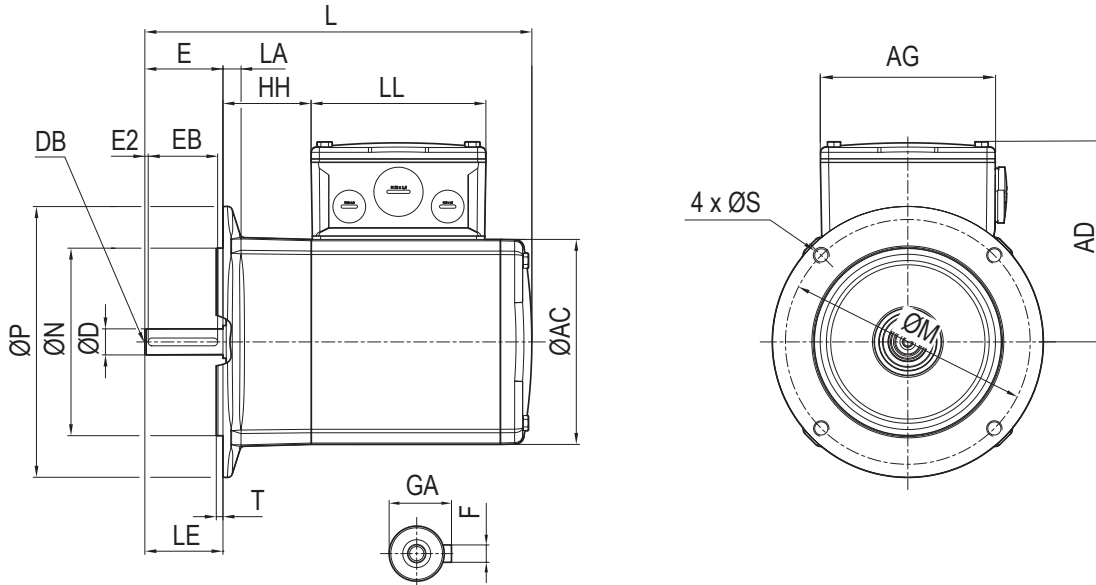

Type	LA	M	N	P	S	D	AC	AD	AG	HH	L	LE	LL	D	DB	E	E2	EB	F	GA
71Nx/8	11	149.2	114.3	165	M6x15	4.0	125	121	105	55	236	47.6	105	15.87	M6	47.6	1.5	42.9	4.76	17.9

### IM B5

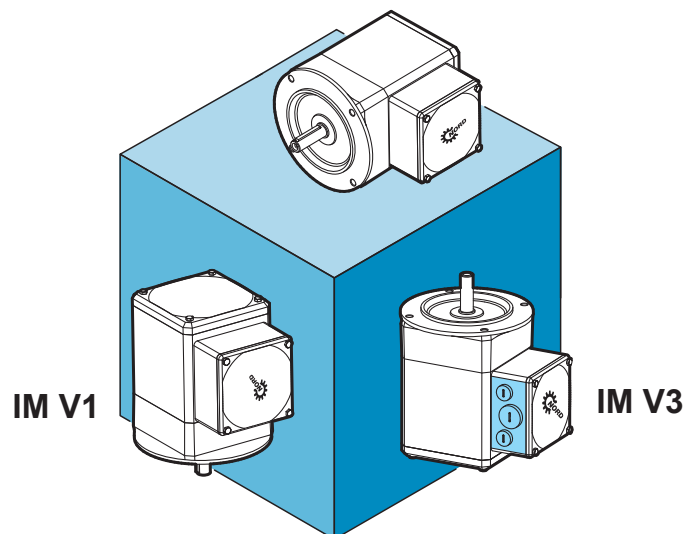





71Nx/8

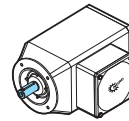
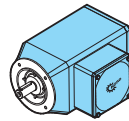
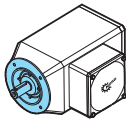
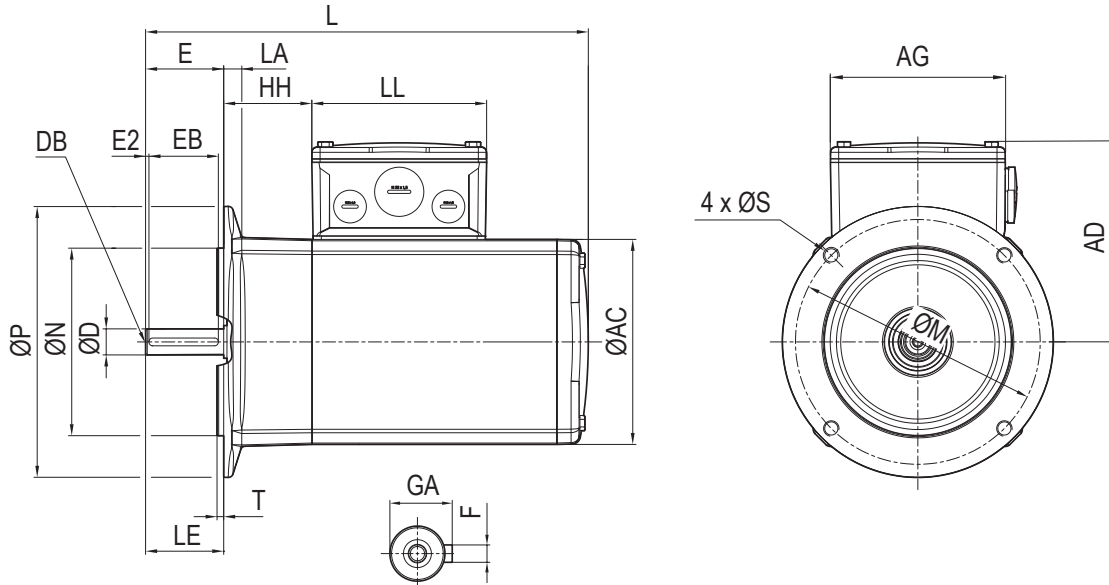

Type	LA	M	N	P	S	D	AC	AD	AG	HH	L	LE	LL	D	DB	E	E2	EB	F	GA
71Nx/8	11	149.2	114.3	165	M6x15	4.0	125	121	105	55	281	47.6	105	15.87	M6	47.6	1.5	42.9	4.76	17.9

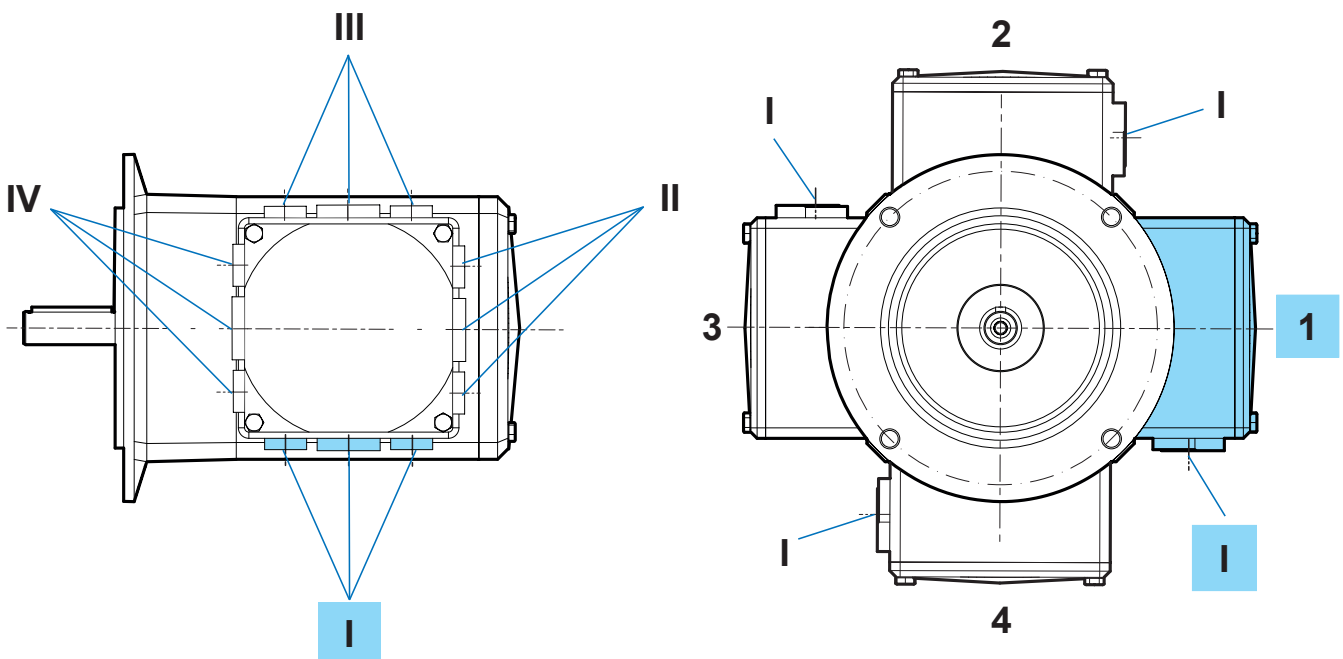

# NORD IE4 B5

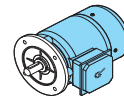
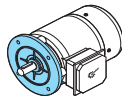
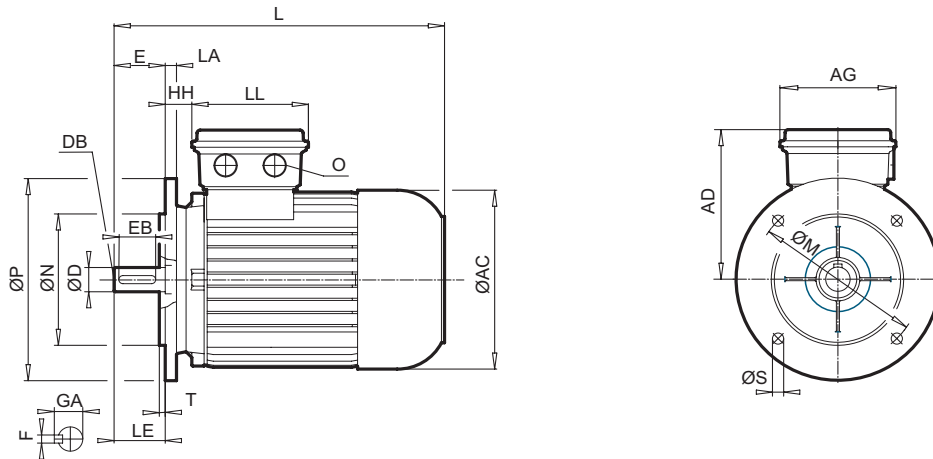

Type	LA	M	N	P	S	D	AC	AD	AG	HH	L	LC	LE	LL
80	11	165	130	200	11	3.5	156	142	114	22	276	309	40	114
90	11	165	130	200	11	3.5	176	147	114	26	326	373	50	114
100	15	215	180	250	13.5	4.0	194	169	114	32	366	422	60	114

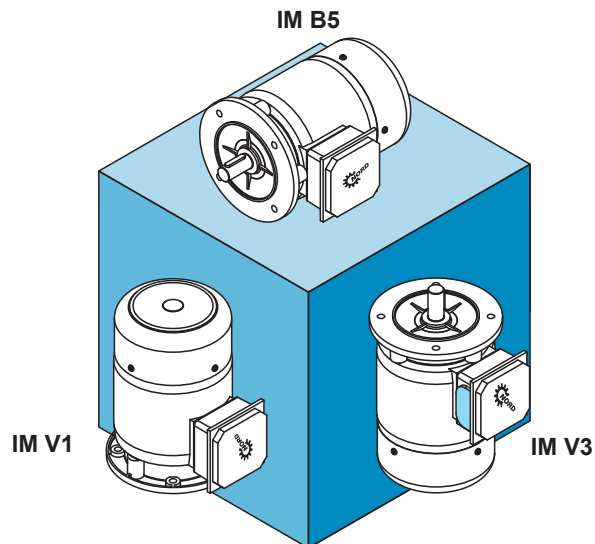

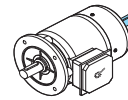
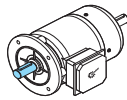
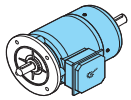
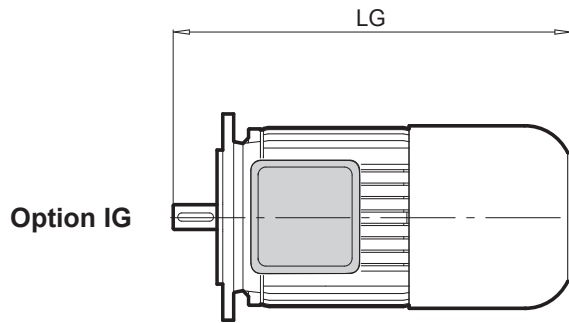

LG	O	D	DB	E	EB	F	GA	DA	DC	EA	EC	FA	GC
337	M25 x 1.5	19	M6	40	32	6	21.5	14	M5	30	20	5	16.0
398	M25 x 1.5	24	M8	50	40	8	27.0	19	M6	40	32	6	21.5
435	M32 x 1.5	28	M10	60	50	8	31.0	24	M8	50	40	8	27.0

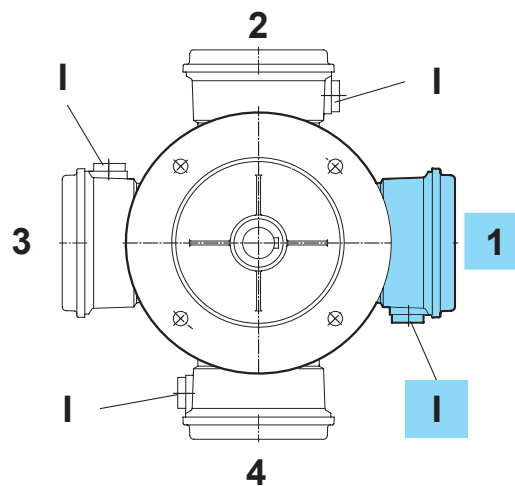
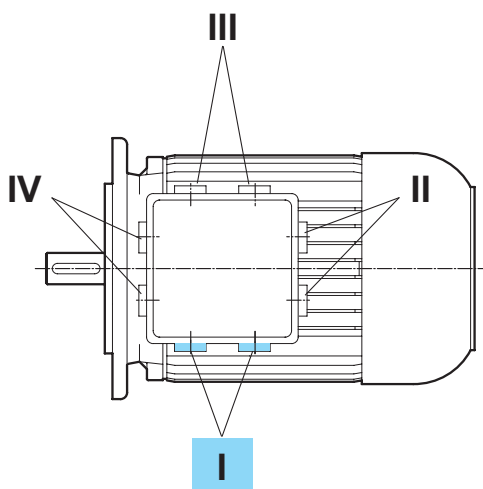

# NORD IE4 B14

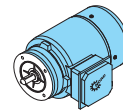
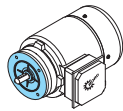
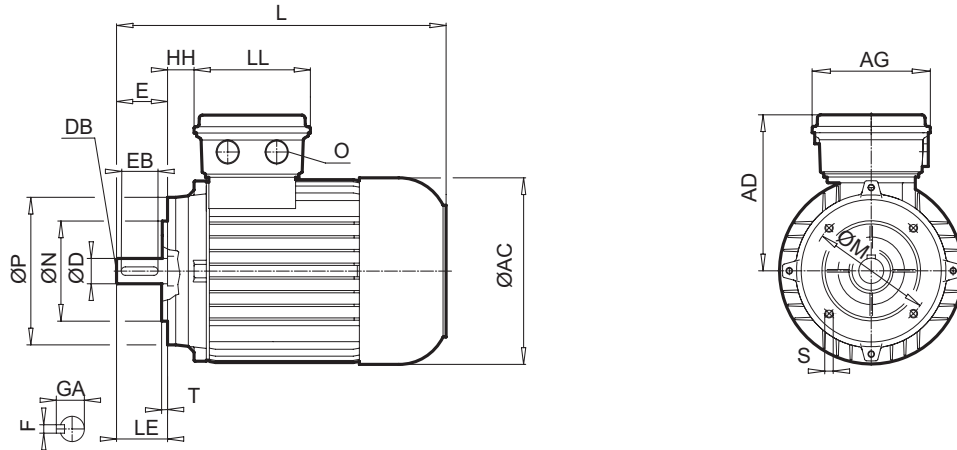

Type	M	N	P	S	D	AC	AD	AG	HH	L	LC	LE	LL
80	100	80	120	M6 x 12	3.0	156	142	114	22	276	309	40	114
90	115	95	140	M8 x 15	3.0	176	147	114	26	326	373	50	114
100	130	110	160	M8 x 16	3.5	194	169	114	32	366	422	60	114

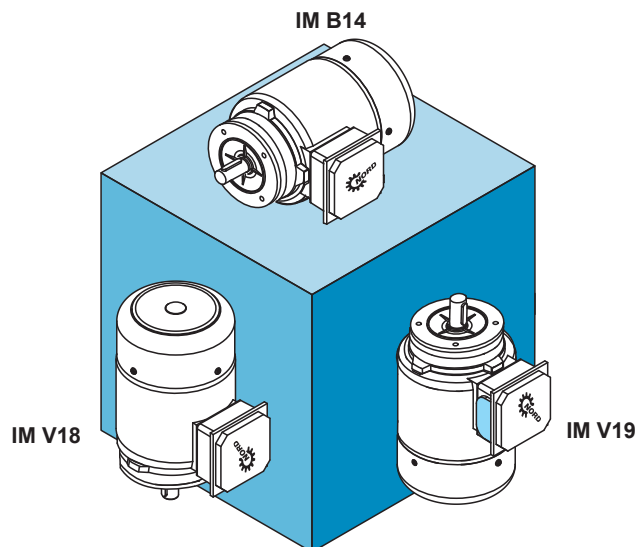

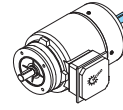
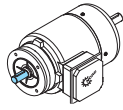
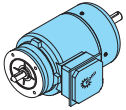
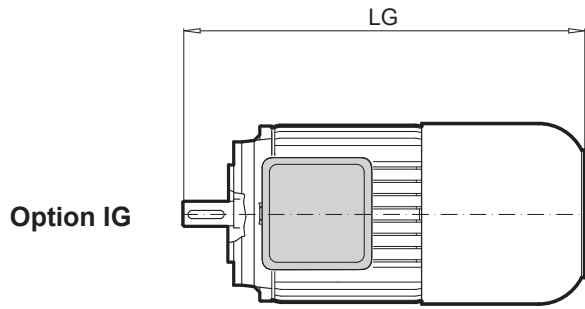

LG	O	D	DB	E	EB	F	GA	DA	DC	EA	EC	FA	GC
337	M25 x 1.5	19	M6	40	32	6	21.5	14	M5	30	20	5	16.0
398	M25 x 1.5	24	M8	50	40	8	27.0	19	M6	40	32	6	21.5
435	M32 x 1.5	28	M10	60	50	8	31.0	24	M8	50	40	8	27.0

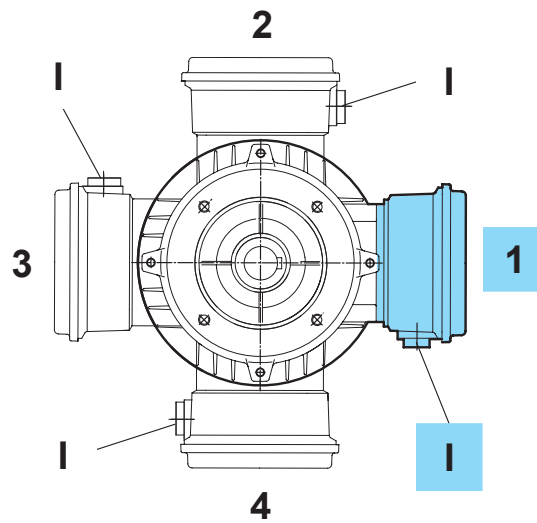
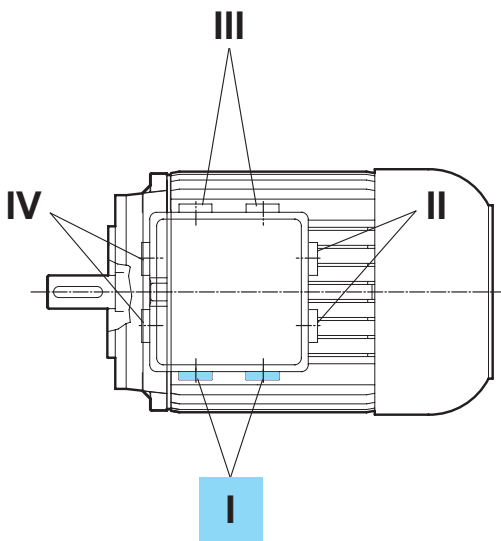

---

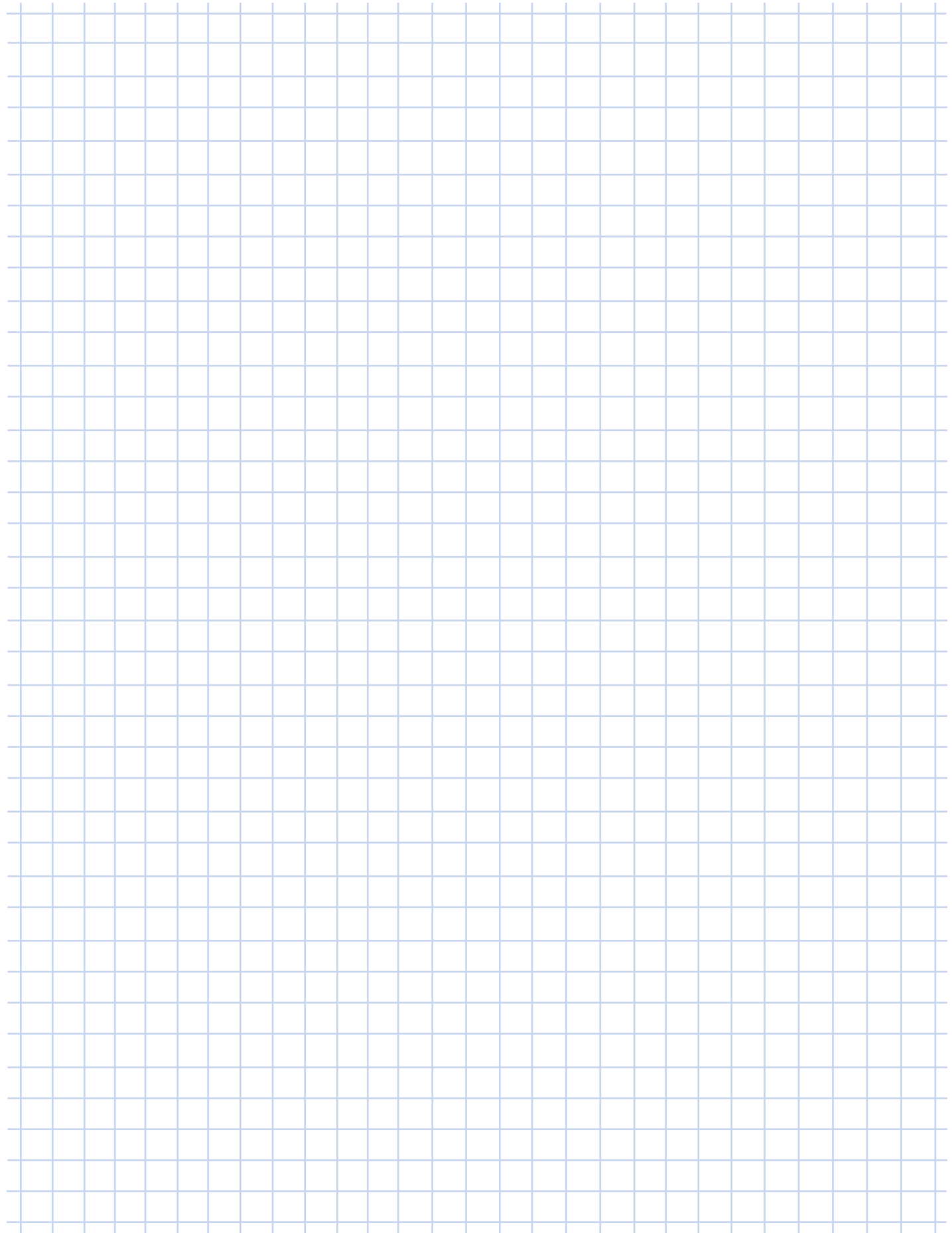

# Selections from the NORD® range

## G1000 Fixed speeds

### UNICASE housing 50 / 60 Hz

- NORDBLOC.1 helical geared motors
- Helical geared motors
- Parallel shaft geared motors
- Bevel geared motors
- Helical worm geared motors

## G4014 Electronic variable speed gear units

- NORDBLOC.1 helical geared motors
- Helical geared motors
- Parallel shaft geared motors
- Bevel geared motors
- Helical worm geared motors

## G1050 MAXXDRIVE® Industrial gear units

### UNICASE housing 50 / 60 Hz

- Parallel gear units
- Bevel gear units

## G1035 UNIVERSAL worm gear units

- SI and SMI

F3018\_E3000 Frequency inverter SK 180E

F3020\_E3000 Frequency inverter SK 200E

F3060\_E3000 NORDAC PRO  
Frequency inverter SK 500P

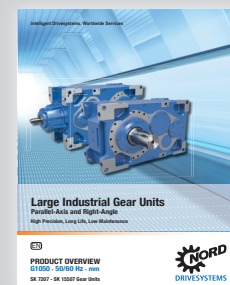

**Intelligent Drivesystems, Worldwide Services**

**NORD DRIVESYSTEMS® Group**

**Headquarters and technology centre  
in Bargteheide near Hamburg**

**Innovative drive solutions  
for more than 100 branches of industry**

**Mechanical products  
parallel shaft, helical, bevel and worm gear units**

**Electrical products  
IE2/IE3/IE4 motors**

**Electronic products  
centralised and decentralised frequency inverters,  
motor starters, and field distributors**

**7 production locations with cutting edge technology  
for all drive components**

**Subsidiaries and sales partners  
in 98 countries on 5 continents  
provide local stocks, assembly centres,  
technical support and customer service**

**More than 4,000 employees throughout the world  
create customised solutions.**

**[www.nord.com/locator](http://www.nord.com/locator)**

**(EN) NORD GEAR LTD.  
11 Barton Lane  
Abingdon Science Park, Abingdon  
OX14 3NB Oxfordshire  
Tel. +44-1235-534404 Fax. +44-1235-534414  
GB-sales@nord.com**

**Member of the NORD DRIVESYSTEMS Group**

  
**DRIVESYSTEMS**