

SK CU4-MBR

Part number: 275 271 010

Electronic brake rectifier

NOTICE

Validity of this document

This document is only valid in combination with the operating instructions for the relevant electronic drive technology and under strict compliance with the safety and warning instructions which they contain. Safe commissioning of this module and the electronic drive technology depends on the availability of this information.

Scope of supply

1 x	Module	SK CU4-MBR
1 x	Mains voltage cable set	brown / black* * incl. fuse (5A slow-acting)
1 x	24 VDC cable set	brown / blue
1 x	Connection cable (digital signal)	black
2 x	Connecting screws	M4 x 20, cross-head



Field of use

Electronic brake rectifier for installation in a decentralised electronic drive technology frequency inverter. With this module it is possible to directly control an electromagnetic brake of between 5 Nm and 150 Nm and a coil voltage of 105 V DC and 205 V DC.

Monitoring of the brake coil current is integrated.

Function description

The module must be supplied with 24 VDC.

The module can be operated with bridge or one way rectification and is designed for various mains and brake coil voltages. The brake is controlled via a digital input. Feedback of the brake status is output via a digital output. The module is equipped with a mains filter, which can be deactivated via a jumper.

Technical Information / Datasheet	SK CU4-MBR			
Electronic brake rectifier	TI 275271010	V 1.0	0116	EN

Technical data

Temperature range	-25°C ... 50 °C
Temperature class	Class 3K3

Vibration resistance	3M7
Protection class	IP20

Mains voltage	100 ... 275 V AC ± 10 % (10 A)
	380 ... 500 V AC ± 10 % (10 A)

Brake current	≤ 0.5 A

For details of the electrical data please refer to the descriptions of the connections (📖 Section "Control terminal details").

Installation

Installation location	In defined option slot inside the frequency inverter (SK 1xxE, 2xxE)
Fastening	with screw fastenings

Installation steps (example illustration)

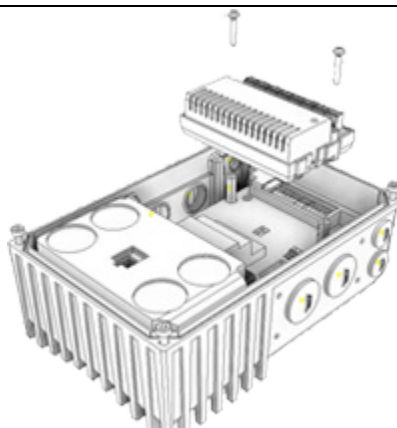
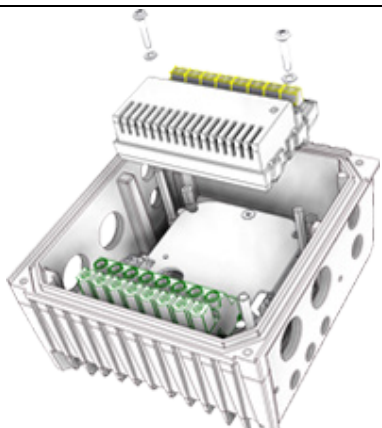
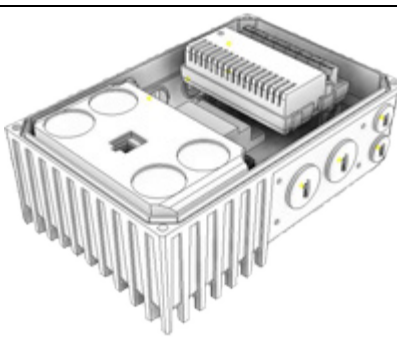
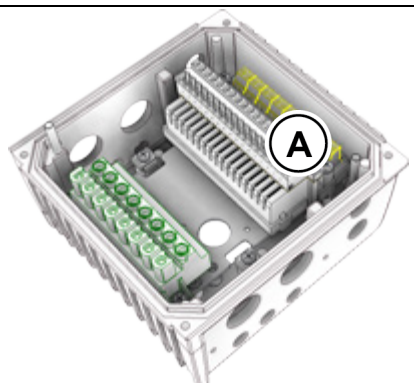
	SK 1xxE	SK 2xxE *)
1.		
2.		

*) Before carrying out installation step 1 it may be necessary to remove the control terminal bar (A),
The control terminal bar (A) must be fitted after installation step 2.

Connections

Terminals	Screw terminals	1 terminal bar with 16 connections, (5 mm spacing)
Cable cross section	0.14...2.5 mm	AWG 14-26
PE connection	Via device	Via screws for installation in the device

Control terminal details

Labelling, function

24 V	Control voltage (input)	GND:	Reference potential for digital signals
DIN:	Digital input	MB:	Brake control
DOUT:	Digital output	L:	Mains connection for a phase

Connections, Functions

SK CU4-MBR-...

Labelling	Function	
		~ Mains potential level:
L2/N	2nd Phase	
L2/N	2nd Phase	
L1 _B	1st Phase (B)	
L1 _B	1st Phase (B)	
L1 _E	1st Phase (E)	
		Brake potential level:
79	MB+	
80	MB-	
		24 V DC potential level:
B5	DOUT	
C5	DIN	
40	GND	
44	24 V	



Compliance with the radio interference class C2 can only be ensured if the mains filter is active (jumper plugged into the upper position).

For use in non-earthed networks (IT network), the mains filter must be deactivated.

To do this, the jumper must be transferred from the top to the bottom.

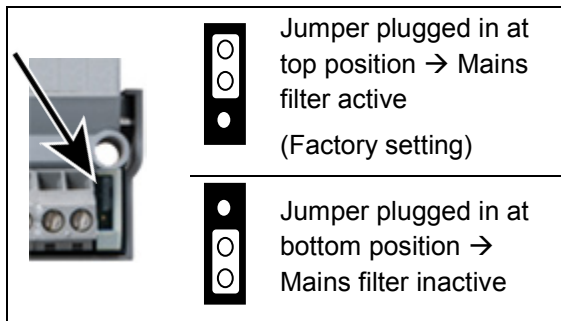

Meaning, Functions		Description / Technical data												
Terminal No.	Designation	Meaning	Parameter No.	Function of factory setting										
Control voltage		For the 24 V control voltage supply to the module												
		24 V DC \pm 25 % 50 ... 500mA (according to load on the digital output)	Short circuit and limited excess temperature or overload monitoring available.											
44	24V	voltage (input)	-	-										
40	GND / 0V	Reference potential GND	-	-										
Digital inputs		Digital input for DC brake switching												
		10 ... 27 V DC \pm 10 % <i>Switching thresholds</i> ON: > approx. 8.5 V OFF: < approx. 7.5 V	<i>Current demand for</i> 30 V DC: 13 mA 24 V DC: 10 mA 15 V DC: 5.5 mA											
C5	DIN	Digital input	-	-										
Digital outputs		Reporting of the current status of the mechanical brake												
		SPS compatible in accordance with EN 61131-2 15 – 30 V DC, 200 mA	Low signal: 0 V / < 30 mA High signal: 24 V / > 70 mA											
B5	DOUT	Digital output	-	-										
Brake control		Output voltage for control of an electromagnetic brake.												
		Assignment of the brake depending on the mains voltage: <table border="1" data-bbox="502 1019 853 1187"> <thead> <tr> <th>Mains</th> <th>Brake</th> </tr> </thead> <tbody> <tr> <td>115 V AC</td> <td>105 V DC</td> </tr> <tr> <td>230 V AC</td> <td>205 V DC</td> </tr> <tr> <td>400 V AC</td> <td>180 V DC</td> </tr> <tr> <td>460/480 V AC</td> <td>205 V DC</td> </tr> </tbody> </table> Current: max. 0.5 A	Mains	Brake	115 V AC	105 V DC	230 V AC	205 V DC	400 V AC	180 V DC	460/480 V AC	205 V DC	The output voltage depends on the supply voltage and the connection of the supply cable to the one-way (L1 _E) or bridge rectification (L1 _B) of the module. <i>Output voltage</i> ...For one-way rectification 0.9 x mains voltage ...for bridge rectification 0.45 x mains voltage Permissible cycle time (1 cycle = 1 x ON + 1x OFF) \geq 0.5 s (for 5 ... 100 Nm brake) \geq 1.0 s (for 150 Nm brake)	
Mains	Brake													
115 V AC	105 V DC													
230 V AC	205 V DC													
400 V AC	180 V DC													
460/480 V AC	205 V DC													
79	MB+	Brake control (+)	-	-										
80	MB-	Brake control (-)	-	-										
Mains connection		Mains voltage connection for one way rectification												
		Mains connection 380 - 500 VAC \pm 10%, max. 10 A												
L1_E	L1	Mains connection 1st Phase	-	-										
L2/N	L2/N	Mains connection 2nd Phase / N	-	-										
		Mains voltage connection for bridge rectification												
		Mains connection 100 - 275 VAC \pm 10%, max. 10 A												
L1_B	L1	Mains supply 1st Phase	-	-										
L2/N	L2/N	Mains supply 2nd Phase / N	-	-										

Connection example

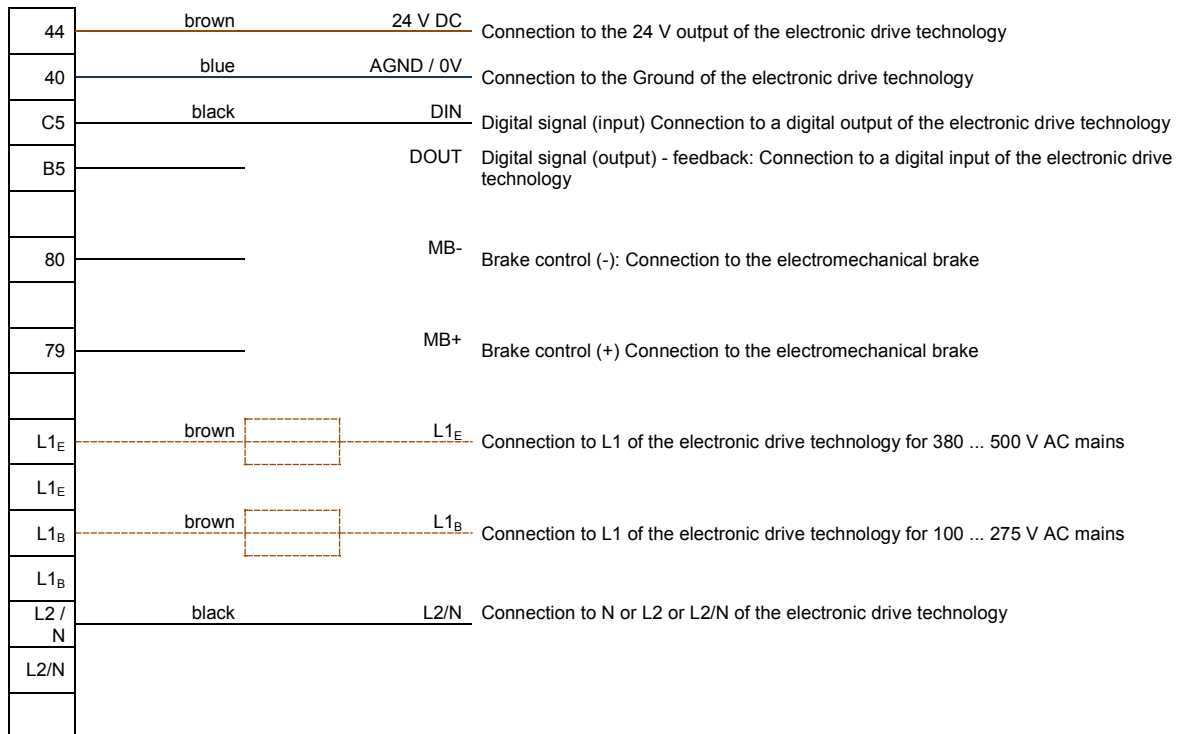

Further documentation (www.nord.com)

Document	Name
BU 0135	Motor starter manual SK 135E, SK 175E
BU 0180	Frequency inverter manual SK 180E, SK 190E

Document	Name
BU 0200	Frequency inverter manual SK 2xxE