

Technical Information / Datasheet

SK TIE4-M12-HTL

Part number: 275 274 512

HTL rotary encoder output connection extension

M12 system plug connector

Scope of delivery

1 x	M12 Socket connector	SK TIE4-M12-HTL
1 x	Cover cap	black

As-delivered status with screwed-on connector cover



Field of use

The M12 Socket connector has open cable ends and wire end sleeves. It is used to make a pluggable connection using normal commercial M12 round plug connectors. It connects the technology option with the outgoing HTL rotary encoder cable at the output side.

Technical data

Version	
Temperature range	-30 ... +90 °C
Contact insert Colour / Material	Black / RAL 9005 Plastic
Round plug connector Material	Metal, CuZn, nickel plated
Connection / Type Round plug connector	M12x1, adjustable Socket connector with flexible strand M16x1.5, metric screw thread
Contact set Contacts / Coding	5 pin, B - coded

Weight	23 g
Connector cover Colour / Material	Black / RAL 9005 Plastic
Protection class (screwed)	IP67
Fastening	Hexagonal nut M16x1.5 *
Contacts / Coding	5 pin, A - coded
Tightening torques * M12x1 Socket connector M16x1.5 Screw thread	0.6 Nm 1.5 Nm

* Suitable assembly spanner commercially available (see Installation)

Cable	
Number of conductors / Cross section	4 x 0.34 mm ²
Wire strands / colours	UL / (br, bl, bk, wt)
Length of wire strands	250 mm
Degree of fouling	3 / 2

Mech. Service life	min. 100 plugging cycles
Operating voltage	max. 60 V
Current rating	4 A
Insulation resistance	≥ 10 ⁸ Ω

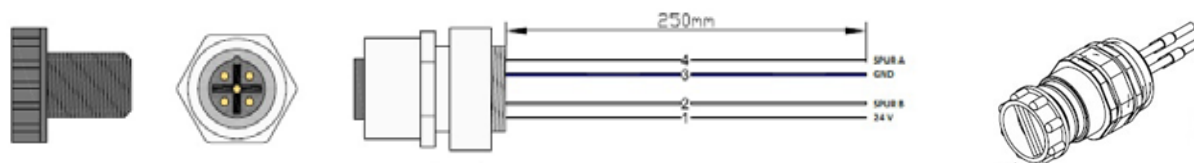

Connection extension				SK TIE4-M12-HTL	
1.1	Extensive revision	2414	Bch	TI 27527412	EN
version	reason for change(s)	issue	name	document	speech

Circuit diagram



Installation / option locations

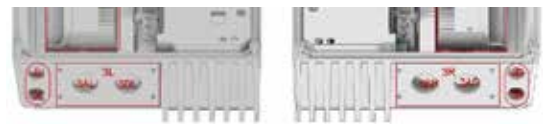

The M12 Receptacle connector are intended for direct installation in a free M16 hole / threaded opening of the device series (see below).









Device series	Recommended option location	Option locations
SK 135E * SK 180E * ... SK 190E * Housing SK 1xxE xxx-xxx-x (-C))	4R / 4L (incoming) 5R / 5L (outgoing)	
SK 200E Frequency inverter connecting unit SK TI4-x-2xx-x (-C)	4R / 4L (incoming) 5R / 5L (outgoing) optional ** 6R / 6L, 7R / 7L, 8R / 8L	
BUS technology box BUS connection unit SK TI4-TU-BUS (-C)	1 / 2 / 3 / 4 optional *** 5R / 5L	
* The configuration capability of the respective Receptacle connector depends on its functionality with regard to the device series, e.g. the SK TIE-M12-SH Socket connector cannot be installed with the SK 1xxE housing. ** Size 1 – 3 with optional SK TIE4-M12-M16 connection extension, size 4 direct installation *** With optional SK TIE4-M20-M16 connection reduction		

The installation position and mounting location (coding pin or coding groove on contact carrier) of the Socket connector is freely positionable and should be aligned (see installation step 6) such that angled M12 round connectors can also be connected in a way that avoids collisions.

The installation steps described in the following apply to the installation of the M12 Receptacle connectors in the housing and in the frequency inverter connecting unit or the BUS connecting unit of an external technology box.

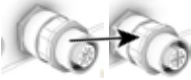
Installation steps for installation of the M12 Receptable connector

1.	Remove M16 blind plug at the provided option location side (right / left) of the starter or frequency inverter housing or the connection unit.	
	Remove M16 blind plug from the provided option location hole (bottom) of the BUS connection unit.	
2.	Screw the middle hexagonal nut towards the front using a size 17 open-ended spanner.	

3.	EMC Twist associated wire pairs together (e. g. bus system, power supply, etc.).		
4.	Screw M12 flanges component directly into the affected M12 threaded opening of the housing or connecting unit of the frequency inverter. Screw M12 Receptable connector into the relevant M16 threaded opening of the BUS connecting unit.		
Alternative option locations Connection extension SK TIE4-M12-M16 The M12 Receptable connector can alternatively be installed with an optional M12-M16 connection extension. First screw the M12 Receptable connector directly into the connection extension and then fit into the M12 threaded opening in the connection unit. For more information see Optional accessories			
Connection reduction SK TIE4-M20-M16 The M12 Receptable connector can alternatively be installed with an optional M20-M16 connection reduction. First screw the M12 Receptable connector directly into the connection reduction and then fit into one of the side M12 threaded openings in the connection unit. For more information see Optional accessories			
5.	Align coding pin / coding groove vertically to 12 o'clock by rotating the front hexagonal nut.	Socket connector 	Plug connector 
6.	Secure the front hexagonal nut with a 17 mm open-ended spanner. Screw the rear hexagonal nut to the connection unit or the starter or frequency inverter housing using a size 17 open-ended spanner or a special torque / installation wrench. Take the specified tightening torques into consideration, see technical data.		
7.	Ensure that the M12 round plug connector or the cover cap is properly screwed onto the M12 Receptable connector and tightened.		

NOTICE

Corrosion

Pay attention to leaktightness during the installation of all components (assembly, connection extension etc.). It must be ensured that all components are correctly seated and the tightening torques are adhered to when doing this.

In order to ensure that protection class **IP66** is complied with (concerns all devices with type key SK ...-C), another **pressure - leaktightness test** must be performed when the assembly work has been completed.

Failure to do this will allow moisture to penetrate the device, which will result in the risk of corrosion and short circuiting.

i Information

Torque / assembly wrench



In order to provide a secure, sealed and vibration-proof connection, the M12 connection extensions, which are equipped with a hexagonal threaded ring (size 17), should be tightened with special torque / assembly wrenches. For professional installation NORD recommends the use of commercially available assembly tools (M12, size 17) with an adjustable, defined tightening torque (e.g. from Murrelektronik).

Connections

The open cable ends of the connection extension / M12 Socket connector are connected to the terminal strip of the control terminals in the frequency inverter (see below).



HTL rotary encoder	Frequency inverter SK 2xxE	BUS technology box SK TU4-... (-M12) / -C
---------------------------	--------------------------------------	---

Electrical connections



Contact assignments
4-pole
Socket connector
B-coded



Connection extension
M12 Socket connector
SK TIE4-M12-HTL

Connection terminals
SK 2xxE

Pin	Colour	Signal	Contact	Designation
1	brown	24 V	43/44*	24 V
2	white	TRACK B	23	DIN3
3	blue	GND	40	GND
4	black	TRACK A	22	DIN2

* 43: 24 V internal, SK 2x0E; 44: 24 V external, SK 2x5E



i Information

Connection to digital inputs

The HTL rotary encoder can **only** be connected to **DIN2** and **DIN3** of the control terminal strip of the frequency inverter. The digital inputs of the customer interfaces and technology assemblies cannot be used for rotary encoders.

Optional accessories

i Information

M12 / M20 screw openings



Conductive connection extensions made from brass SK TIE4-M12-M16 from M12 to M16 or connection reductions SK TIE4-M20-M16 from M20 to M16 are optionally available for installing the M12 connection extensions in an M12 or M20 screw opening. For more information, see further documentation.

Further documentation (www.nord.com)

Document	Designation
BU 0200	Frequency inverter manual SK 2xxE
TI 275280000	Bus connection unit SK TI4-TU-BUS
TI 275280500	Bus connection unit SK TI4-TU-BUS-C
TI 275274510	Connection extension SK TIE4-M12-M16

Document	Designation
TI 275274511	Connection reduction SK TIE4-M20-M16
TI 18552090	Level adaptation PCB HTL - RS422
TI 18552095	Level adaptation PCB HTL - HTL A+/- B+/-