

SK TU4-PNS-C

Part number: 275 281 166

PROFIsafe® – External bus interface

The bus interface may only be installed and commissioned by qualified electricians. An electrician is a person who, because of their technical training and experience, has sufficient knowledge with regard to

- Switching on, switching off, isolating, earthing and marking power circuits and devices,
- Proper maintenance and use of protective devices in accordance with defined safety standards.

DANGER

Danger of electric shock

The frequency inverter carries hazardous voltage for up to 5 minutes after being switched off.

- Work must not be carried out unless the frequency inverter has been disconnected from the voltage and at least 5 minutes has elapsed since the mains was switched off!

NOTICE

Validity of document

This document is only valid in conjunction with the operating instructions of the respective frequency inverter and the bus communication manual for this bus interface (📖 See overview at end of document). These documents contain all of the information that is required for safe commissioning of the bus interface module and the frequency inverter.

Scope of delivery

| | | |
|------------------------------|-------------------------------------|---|
| 1 x | Bus interface | SK TU4-PNS-C |
| 4 x | Hexagonal socket screw | M4 x 40 mm |
| Accessories required: | | |
| 1 x | Bus connection unit TI 275280800 | SK TI4-TU-SAFE-C (Part No.: 275280800) |



| Technical Information / Datasheet | | SK TU4-PNS-C | | | |
|-----------------------------------|--|--------------|-------|------|----|
| PROFIsafe bus interface | | TI 275281166 | V 1.3 | 1618 | en |

Field of use

External technology unit for connecting a decentralised frequency inverter (SK 2xxE) to a **PROFIsafe** field bus. The bus interface can be mounted on, or in the immediate vicinity of the frequency inverter. This is connected to the frequency inverter via the system bus.

The bus interface can directly control up to 4 frequency inverters via PROFINET IO based on the system bus.

2 secure digital inputs, 2 clock outputs and 3 secure digital outputs are available. Therefore a maximum of 3 frequency inverters (devices with safe inputs) can be directly controlled via the safe outputs of the bus interface.

The bus interface can also be used as a "stand-alone" safety module, independent from a frequency inverter.

Technical Data

Applied standards

| Standards "functional safety" | EMC standards |
|-------------------------------|--------------------------------|
| EN ISO 13849-1 | EN 61326-1: 2013 ¹⁾ |
| EN 62061 | EN 61326-3-1: 2008 |
| EN 61508 Part 1-7 | |

¹⁾ With regard to resistance from interference due to electromagnetic fields, in the range 80 MHz to 1 GHz the module is only suitable for the basic electromagnetic environment. The safety criterion according to EN 61326-3-1 is not affected.

Bus interface

| | |
|-------------------|---|
| Temperature range | -25 °C...40 °C |
| Temperature class | Class 3k4 |
| Protection class | IP66 |
| Supply voltage | 24 V + 25 % / - 20 %, ≈ 140 mA reverse polarity protected |

| | |
|-------------------------------|------------------------------|
| Vibration resistance | 3M7 |
| Firmware (PROFINET) | V2.0 R5 |
| Firmware (PROFIsafe) | V1.4 R0 |
| Dimensions [mm] ¹⁾ | H x W x D: 95 x 136 x 109 |

- ¹⁾
- Bus interface fitted to bus connection unit
 - Depth: 154 mm with cover caps on RJ45 connection

| | | Key values according to | |
|---|---------------------|--|--------------------|
| | | EN 62061 / IEC 61508 | EN ISO 13849-1 |
| Classification / Basic standards | | SIL 3 according to IEC 61508 ¹⁾ | PL e ¹⁾ |
| Operating mode | | "High demand" according to IEC 61508 | |
| Probability of a hazardous failure per hour (PFH value) | SI, SO | 3 x 10 ⁻⁹ 1/h | |
| | Sin/Cos encoder, SO | 30 x 10 ⁻⁹ 1/h | |
| Lifetime | | 20 years | |
| Proof Test Interval | | 20 years | - |

1)

WARNING
Loss of safe function

- An external short circuit between + 24 V and a safe input (SI) is not detected!
- An external short circuit between + 24 V and a safe output (SO) results in the module being switched off with an error message to the fail safe controller. However, the 24 V short circuit is not switched off!

If exclusion of errors by means of safe wiring is not possible, both the safe input as well as the safe output can be connected with two channels. Dual channel operation must be set by parameterisation.

Bus specification

| | |
|-----------------|---|
| PROFIsafe | max. 100 MBaud electrical isolation 500 V _{eff} |
| Bus connection | 2 x RJ45 |
| Bus termination | performed automatically |
| Status display | 6 LEDs |
| Topology | Star, tree, ring, line |

| | |
|-------------------|----------------------------------|
| Cable | Min. Ethernet CAT-5 |
| Max. cable length | 100 m between two bus interfaces |
| Shield | See Shielding information |
| PE connection | via PE screw cap in terminal box |

 **Information**
Wiring / Shielding

The wiring between the bus module and the frequency inverter must comply with the section "**Exclusion of wiring errors**" in the **Functional Safety** section of the manual for the particular frequency inverter ([BU 0230](#) / [BU 0235](#) / [BU 0530](#)).

The PE is connected to the various circuit board levels via the screw fastenings of the circuit boards.

- Shielding of the bus cable is connected directly to PE via the RJ45 connection.
- Shielding of the IOs must be connected to the PE connection (PE screw terminal in the connection box).
- A separate cable with its own shielding must be used for the digital outputs.

Power

| | |
|---|---------|
| Update interval for process data between bus interface and frequency inverter | ≥ 5 ms |
| Parameter read access on the frequency inverter | ≈ 15 ms |
| Parameter write access with storage in EEPROM | ≈ 25 ms |
| Cycle times | ≥ 1 ms |

Additional information for SAFE

| Subject | Specification | Unit | min. | Typically | max. |
|-------------------------|--|-------|------|-----------|------------|
| Power supply | Power supply to the module from a safely isolated mains unit | [V] | 19.2 | 24 | 30 |
| | <ul style="list-style-type: none"> 24 V consumption by SK TU4-PNS when idle Additional requirement for digital outputs and clock outputs (for details, also refer to "Digital outputs") Additional requirement for SIN/COS-encoder supply (depends on manufacturer) | [mA] | | 140 | 1000 |
| | | | | | 150 |
| Digital outputs | Low Signal output voltage | [V] | | 0 | 0.8 |
| | High Signal output voltage | [V] | 17 | 24 | 30 |
| | Output current (OSSD 1...3) peak | [mA] | | | 300 500 |
| | T_{OSSD} = Test pulse cycle | [ms] | 50 | 50 | 50 |
| | $t_{OSSDoff}$ = Pulse length (variable in 200 μ s steps) | [ms] | 0.3 | 0.5 | 2.0 |
| | t_{OSSDon} = Pulse pause ($t_{OSSDoff} \times 2$) | [ms] | 0.8 | 1.2 | 4.0 |
| | $t_{OSSDerror}$ = Detection of an OSSD error $t_{OSSDerror} = T_{OSSD} \times 3$ | [ms] | 100 | - | 150 |
| Digital inputs | Low Signal input voltage | [V] | -3 | 0 | 5 |
| | High Signal input voltage | [V] | 15 | 24 | 30 |
| | High Signal input current | [mA] | | | 6 |
| | Response time | [ms] | | | 30 |
| | T_{OSSD} = Test pulse cycle(contact test) | [ms] | 50 | | |
| | $t_{Testoff}$ = Pulse length | [ms] | 0.3 | 0.5 | 2.0 |
| | Switch-on delay | [ms] | 0 | 0 | 100 |
| Clock outputs | Low Signal output voltage | [V] | | 0 | 0.8 |
| | High Signal output voltage | [V] | 17 | 24 | 30 |
| | Output current | [mA] | | | 50 |
| | T_{Takt} = Test pulse cycle | [ms] | 50 | | |
| | $t_{Taktoff}$ = Pulse length | [ms] | | | 2.0 |
| Encoder | Input voltage | [V] | | 2.25 | 2.75 |
| | Maximum encoder frequency | [kHz] | | | 150 |
| Temperatures | Ambient temperature | [°C] | -25 | | 40 |
| | Storage temperature | [°C] | -25 | | 85 |
| Protection class | Dust-tight and protected against (strong) water jets | IP | 55 | 55 | 66 |

Bus interface characteristics

| | |
|------------------------------------|---|
| Communication | RT (Real Time) → Real time communication of process data |
| | IRT (Isochronous Real Time) → Isochronous real time communication of synchronised process data |
| Addressing PROFINET IO | Automatic address assignment via IO controller using DCP (Discovery Configuration Protocol) |
| Data transfer | via Switched Ethernet |
| Autonegotiation | Negotiation of transfer parameters |
| Autocrossover | Transmission and receiver cables are automatically crossed in the switch as necessary |
| Conformity classes | CC-B and CC-C |
| Access for NORD diagnosis tool via | <ul style="list-style-type: none"> • Diagnostics socket on the device (if available) and via frequency inverter • Ethernet protocols UDP or TCP/IP possible |

| | |
|----------------------|--|
| Safety communication | Monitoring of process data, sequential numbering of PROFIsafe telegrams (24-bit counter) and checksum test (CRC) |
| PROFIsafe addressing | F address via DIP - switches |

Installation

The bus interface must be attached to a suitable connection unit (SK TI4-TU...) and connected using the 4 provided M4 x 40 mm hexagon socket collar screws. Installation details can be found in the data sheet for the relevant connection units.

Connections

The two Ethernet lines are connected exclusively via the two RJ45 sockets on the front. If the module is the final participant on the line, one RJ45 socket can remain unoccupied.

| RJ45 PIN | Signal | Description |
|----------|--------|---------------------|
| 1 | TX+ | Transmission Data + |
| 2 | TX- | Transmission Data - |
| 3 | RX+ | Receive Data + |
| 6 | RX- | Receive Data - |



PIN connections
RJ45 socket:

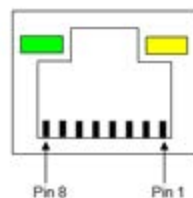

Connection of the other signal and control cables is made via the Bus: connection unit **SK TI4-TU-SAFE(-C)**

| | | |
|---------------------|-----------------------------------|---|
| Terminals | Double spring-loaded terminal bar | 2 x 18 contacts |
| Cable cross section | AWG 14-26 | rigid: 0.14 ... 2.5 mm flexible: 0.14 ... 1.5 mm with wire end sleeves |
| PE connection | via housing | |
| RJ12 | RJ12 socket | Interface for connecting parametrisation tool |

| Area | Contact | Designation | Description | |
|------|-------------------------------------|-------------|-------------|--|
| 1 | Encoders | 1 | A Out | Track A for external processing – 24V square wave signal |
| | | 2 | B Out | Track B for external processing – 24V square wave signal |
| | | 3 | A+ | Differential SIN signal + |
| | | 4 | B+ | Differential COS signal + |
| | | 5 | A- | Differential SIN signal - |
| | | 6 | B- | Differential COS signal - |
| | | 7 | 0V | Reference potential (0 V / GND) |
| | | 8 | 0V | Reference potential (0 V / GND) |
| | | 9 | 24V | Supply potential (+24 V, ≤ 200 mA) |
| | | 10 | 24V | Supply potential (+24 V, ≤ 200 mA) |
| 2 | System bus level and digital inputs | 11 | 24V | Supply voltage (+24 V) |
| | | 12 | 24V | Supply voltage (+24 V) |
| | | 13 | 24V | Supply voltage (+24 V) |
| | | 14 | SYS + | System bus data line + |
| | | 15 | 0V | Reference potential (0 V / GND) |
| | | 16 | SYS - | System bus data line - |
| | | 17 | 0V | Reference potential (0 V / GND) |
| | | 18 | 0V | Reference potential (0 V / GND) |
| | | 19 | SI1 | Safe digital input 1 |
| | | 20 | SI2 | Safe digital input 2 |
| | | 21 | 0V | Reference potential (0 V / GND) |
| | | 22 | 0V | Reference potential (0 V / GND) |
| | | 23 | 24V | Supply voltage (+24 V) |
| | | 24 | 24V | Supply voltage (+24 V) |
| 3 | Digital outputs | 25 | Clock 1 | Clock output for safe input 1 ¹⁾ (p-switching, OSSD) |
| | | 26 | Clock 2 | Clock output for safe input 2 ¹⁾ (p-switching, OSSD) |
| | | 27 | 0V | Reference potential (0 V / GND) |
| | | 28 | 0V | Reference potential (0 V / GND) |
| | | 29 | 24V | Supply voltage (+24 V) |
| | | 30 | 24V | Supply voltage (+24 V) |
| | | 31 | SO1 | Safe output 1 (pp switching, OSSD) |
| | | 32 | 0V | Reference potential (0 V / GND) |
| | | 33 | SO2 | Safe output 2 (pp switching, OSSD) |
| | | 34 | SO3 | Safe output 3 (pp switching, OSSD) |
| | | 35 | 0V | Reference potential (0 V / GND) |
| | | 36 | 0V | Reference potential (0 V / GND) |
| 4 | Diagnostics | RJ12 - 1 | RS485_A | Data cable RS485 |
| | | RJ12 - 2 | RS485_B | Data cable RS485 |
| | | RJ12 - 3 | GND | Reference potential (GND) |
| | | RJ12 - 4 | RS232_TxD | Data cable RS232 |
| | | RJ12 - 5 | RS232_RxD | Data cable RS232 |
| | | RJ12 - 6 | 5 V | Supply voltage (+5 V) |



1) Clock output is not safety-rated.

Connection of the cable sets (scope of delivery)

The following cable sets are included in scope of delivery:

- Systembus
- HTL-signal (for signal processing in the frequency inverter) ^{a)}
- Safe Stop
- Voltage supply
- PE

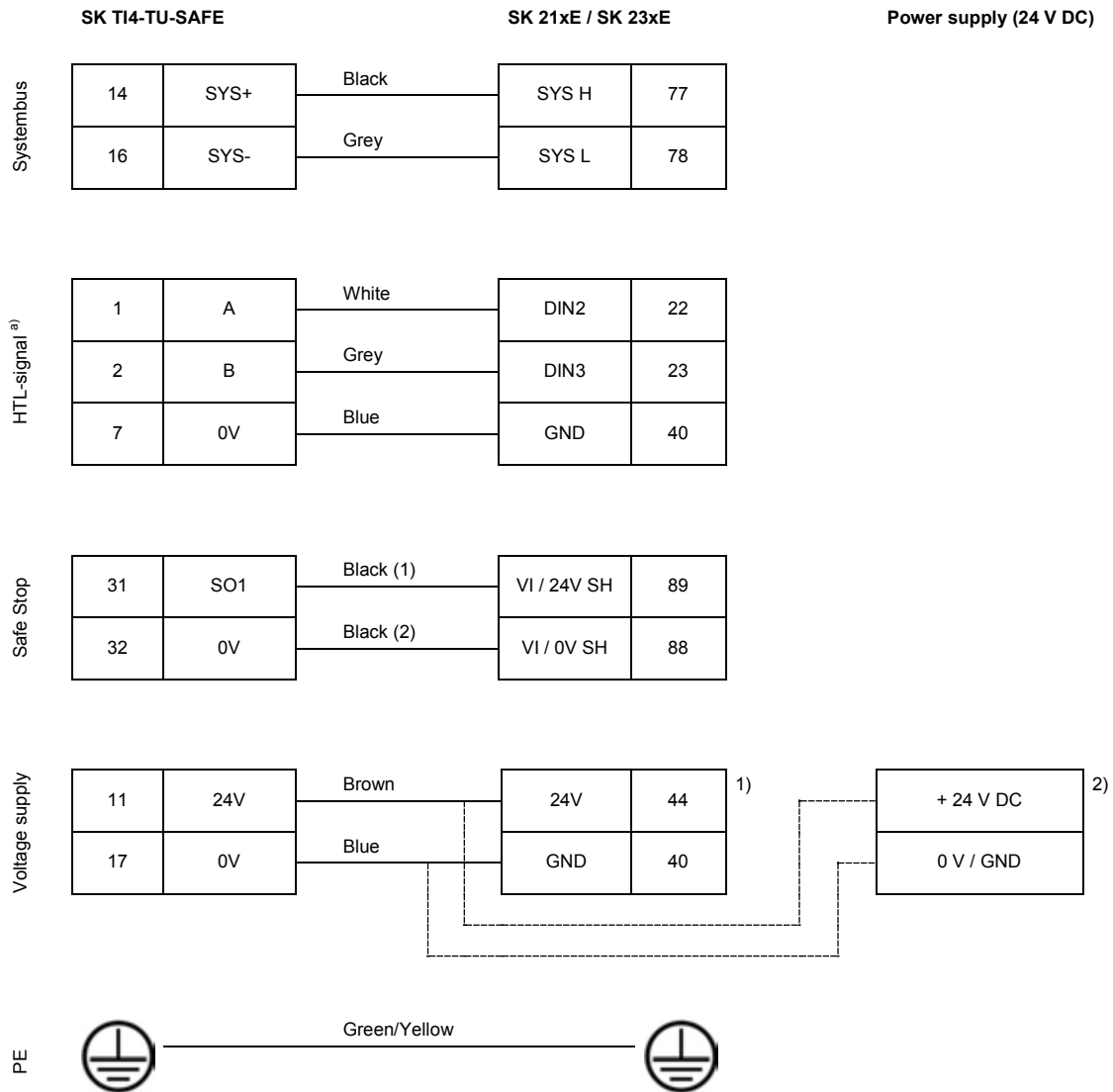

SK TI4-TU-SAFE-...

SK 21xE / SK 23xE

Power supply (24 V DC)

1) Only valid for devices SK 215E / SK 235E.

2) For devices SK 210E / SK 230E or for higher power requirements of the bus interface (eg due to IOs) an external power supply have to be used.

a) **REMARK:** Don't connect encoder!

Encoder connection

A safety SIN /COS encoder can be connected to implement the safety functions.

i Information

Measurement precision

The encoder is evaluated by measuring the frequency. The higher the working frequency which is selected the greater the precision.

To prevent large incorrect measurements, at least 500 measuring steps per second should be selected.

The number of measuring steps per second is calculated from the speed of rotation of the encoder and the selected encoder resolution.

$$inc/s = \frac{RPM \times Resolution}{1500}$$

The following diagram shows the percentage measuring error for the set number of steps.

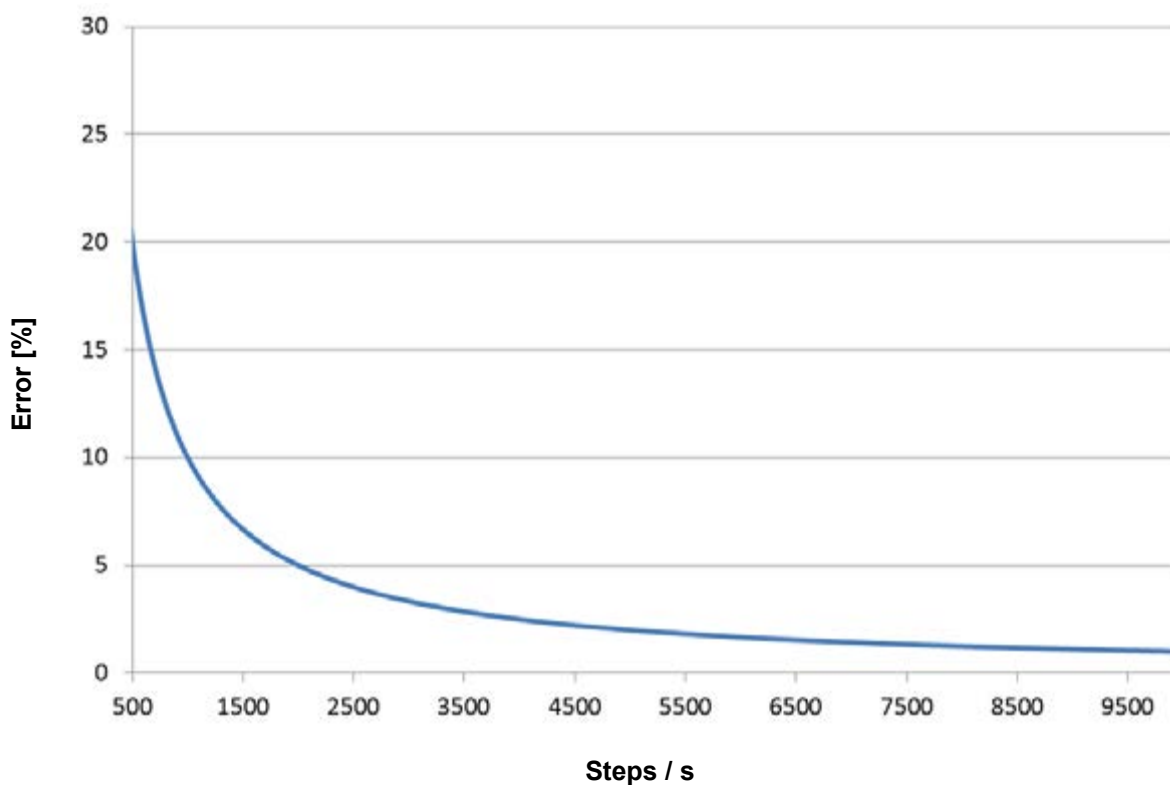

i Information

Standstill detection

NB:

With the use of a single encoder for standstill detection, reduced availability is to be expected under unfavourable EMC conditions. This must be taken into account during planning and compensated for by setting a larger maximum position error.

Configuration

Configuration of the module for remote maintenance or for the system bus is carried out via the DIP switches. The DIP - switch settings are read after a "Power On" of the module.

| DIP switch | | | | | | | | | | | Meaning | |
|--------------------------------------|----|----|------------------|---|---|---|---|---|---|---|---|---|
| 12 | 11 | 10 | 9 | 8 | 7 | 6 | 5 | 4 | 3 | 2 | 1 | |
| X | X | X | F-address | | | | | | | | X | |
| | | | | | | | | | | | 0 | System bus terminating resistor not set |
| | | | | | | | | | | | 1 | System bus terminating resistor set |
| Access rights for remote maintenance | | | | | | | | | | | | |
| | | 0 | | | | | | | | | Only read access to parameters possible. | |
| | | 1 | | | | | | | | | Read and write access to parameters possible. | |
| | | 0 | | | | | | | | | No control possible. | |
| | | 1 | | | | | | | | | Control is possible. | |
| 0 | | | | | | | | | | | | TCP/IP open connection. |
| 1 | | | | | | | | | | | | Secure TCP/IP connection. |

1. System bus (DIP 1)

The system bus must be terminated at both physical ends.

2. F-address (DIP 2 - 9)

Setting the F-address

3. Access rights for remote maintenance (DIP 10 – 12)

Via the Ethernet protocols TCP and UDP the module and the connected frequency inverter can be accessed using remote maintenance. The type of access is determined via the DIP - switch with inputs 10 to 12.



Factory settings DIP switches: OFF

LED indicators

The operating statuses of the bus interface are visualised using LED indicators.

| No. | Name | Colour | Meaning |
|-----|------|--------|----------------|
| 1 | FE | red | F Data Error |
| | FS | green | F Data State |
| 2 | RUN | green | Ethernet State |
| | BF | red | Ethernet Error |
| | DS | green | Device State |
| | EN | red | Device error |
| 3 | Link | green | Link |
| | Act | yellow | Activity |



PROFINET-specific LED

| RUN (Ethernet State) | Meaning |
|-------------------------|--|
| OFF | No operating voltage Initialisation |
| Flashing green | No connection to PROFINET IO controller No parameter communication No process data communication |
| Green ON | Parameter communication active Process data communication active |

| BF (Ethernet Error) | Meaning |
|--|--|
| OFF | No error |
| Flashing red | No process data communication → e.g. incorrect GSDML file |
| Red ON | Ethernet error → there is no physical connection to a further subscriber |
| Double-flashing red (2 x 0.25 s,+ 1sec pause) | PROFINET or FU timeout, (see also P151, P513) |

| Link (Green LED) | Activity (Yellow LED) | Meaning |
|---------------------|----------------------------|--|
| OFF | OFF | <ul style="list-style-type: none"> Bus interface not ready, no control voltage, No bus connection (check cable connection) |
| ON | OFF | <ul style="list-style-type: none"> Bus connection (cable connection) to another Ethernet device exists No bus activity present |
| ON | Flashing (Blinking) | <ul style="list-style-type: none"> Bus connection (cable connection) to another Ethernet device exists Bus activity present |

PROFIsafe-specific LED

| FS (F Data State) | Meaning |
|-----------------------|--|
| OFF | No operating voltage Initialisation |
| Brief flashing | No cyclic SAFE data exchange |
| Flashing | Cyclic exchange of data, bus interface waiting for reintegration |
| On | Cyclic data exchange in operation |

| FE (F Data Error) | Meaning |
|----------------------|---|
| OFF | No error |
| Red ON | SAFE- bus interface hardware error |
| Flashing red | PROFIsafe error (for flashing code and error codes see Manual BU 2800) |

NORD-specific LEDs

| DS (Device State) | EN (Device Error) | Meaning long flashing = 0.5 s on / 1 s off short flashing = 0.25 s on / 1 s off |
|----------------------|--|--|
| OFF | OFF | Bus interface not ready, no control voltage |
| ON | OFF | Bus interface ready, no error, at least one frequency inverter is communicating via the system bus |
| ON | Short flashing | Bus interface ready, but <ul style="list-style-type: none"> • One or more of the connected frequency inverters has fault status |
| Long flashing | OFF | Bus interface ready and at least one other subscriber is connected to the system bus, but <ul style="list-style-type: none"> • No frequency inverter on the system bus (or connection interrupted) • One or more system bus subscriber has an address error • Software incompatible (bus interface software and FI software incompatible - update required) |
| Long flashing | Short flashing Flash interval 1 x - 1s pause | System bus is in status "Bus Warning" <ul style="list-style-type: none"> • Communication on system bus disrupted • No other subscribers present on system bus • Module not inserted correctly or no connection to system bus • Frequency inverter has no supply voltage |
| Long flashing | Short flashing Flash interval 2 x - 1s pause | System bus is in status "Bus Off" <ul style="list-style-type: none"> • The system bus 24 V power supply has been interrupted during operation |
| Long flashing | Short flashing Flash interval 3 x - 1s pause | System bus is in status "Bus Off" <ul style="list-style-type: none"> • The 24V voltage supply of the system bus is missing |
| Long flashing | Short flashing Flash interval 4 x - 1s pause | Bus interface error <ul style="list-style-type: none"> • See parameter P170 |
| OFF | Short flashing Flash interval 1...7 - 1s pause | System error, internal program sequence interrupted <ul style="list-style-type: none"> • EMC interference (observe the wiring guidelines!) • Bus interface defective |

Error messages

Error messages from the bus interface can be read out via parameter **P170** of the bus interface (Array [-01] = Actual error, Array [-02] = Previous error).

| Error | Meaning | Comments |
|-------|-----------------------------|---|
| 100.0 | EEPROM error | EMC fault, bus interface defective |
| 101.0 | System bus 24 V missing | No 24 V voltage on bus, connections not correct |
| 102.0 | Bus timeout P151 | By means of timeout supervision parameter P151 |
| 103.0 | System bus Off | No 24 V voltage on bus, connections not correct |
| 550.0 | General configuration error | No Ethernet connection (see E10.5) |
| 550.2 | Hardware error System bus | EMC fault (see E10.6) |
| 550.3 | SAFE hardware error | Error in the safety module (see E10.7) |
| 550.4 | FI lost | Connection to system bus participant (FI) lost |
| 550.5 | AR lost | PROFINET telegram failure, connection to the IO controller lost (see E10.2) |
| 564.0 | MAC address error | MAC address defective |

Error messages which occur in relation to the bus interface are depicted as follows in the error memory of the frequency inverter (Parameter **P700** and **P701**).

| Error (E010) | Meaning | Comments |
|--------------|--------------------------------------|---|
| 10.0 | Connection error | <ul style="list-style-type: none"> • Contact to bus interface lost |
| 10.2 | PROFINET telegram failure | <ul style="list-style-type: none"> • Check physical bus connections • Check the status of the PROFINET IO controller |
| 10.3 | Timeout through P151 | <ul style="list-style-type: none"> • System bus monitoring has triggered. <ul style="list-style-type: none"> – Check time setting parameter P151 • Telegram transfer is faulty. <ul style="list-style-type: none"> – Reception of cyclic telegrams • Check physical bus connections |
| 10.5 | General PROFINET configuration error | <ul style="list-style-type: none"> • Connection to the Ethernet lost. |
| 10.6 | System bus hardware error | <ul style="list-style-type: none"> • Remedy EMC fault |
| 10.7 | Hardware error, Safe bus interface | <ul style="list-style-type: none"> • An error has occurred in the safe hardware. <ul style="list-style-type: none"> – Remedy EMC fault – Restart the bus interface |
| 10.8 | Timeout connection error | <ul style="list-style-type: none"> • Connection between bus interface and frequency inverter interrupted due to timeout. |
| 10.9 | Module missing P120 | <ul style="list-style-type: none"> • The module entered in parameter P120 is not available. |

PROFIsafe error messages

| Error | Meaning | Remarks |
|-------|---------------------------|--|
| 5711 | Incorrect client address | DIP switch setting or parameterised target address incorrect |
| 5712 | Invalid client address | |
| 5713 | Invalid host address | Incorrect source address |
| 5714 | Watchdog time is zero | A watchdog time of zero is invalid |
| 5715 | Incorrect F-SIL | F_SIL level set too high in the controller |
| 5716 | Incorrect F-Par version | The F-Par version is not compatible with the bus interface |
| 5717 | Incorrect checksum | The checksum for the F-parameter is incorrect |
| 5718 | General F parameter error | |

| Error | Meaning | Remarks |
|-------|---|---|
| 5719 | Incorrect i-parameter checksum | Different checksum in controller and bus interface |
| 5721 | Different CRC length | |
| 5722 | i-parameters have been changed | |
| 5723 | Different i-parameter checksum | The checksum and the i-parameter do not match |
| 5724 | Incorrect i-parameter checksum | The checksum and the i-parameter do not match |
| 5725 | Incorrect F parameter telegram | |
| 5726 | Error when reading in DIP switches | DIP switches possibly set to zero |
| 5731 | Discrepancy test | Discrepancy at inputs |
| 5723 | Diagnostic error at output 1 | Short circuit or cross circuit |
| 5723 | Diagnostic error at output 2 | |
| 5734 | Diagnostic error at output 3 | |
| 5735 | Diagnostic error at clock output 1 | |
| 5736 | Diagnostic error at clock output 2 | |
| 5741 | iPar error OSSD1 channel activation | Output activated without activating channel |
| 5742 | iPar error OSSD2 channel activation | |
| 5743 | iPar error OSSD3 channel activation | |
| 5744 | iPar error Clock cycle 1 channel activation | |
| 5745 | iPar error Clock cycle 2 channel activation | |
| 5746 | iPar error SI1 channel activation | Input activated without activating channel |
| 5747 | iPar error SI2 channel activation | |
| 5748 | iPar error i parameter channel activation | Incorrect setting of P802 Channel activation |
| 5749 | iPar error OSSD signal pulse length | Incorrect setting of parameter P804 OSSD Pulse |
| 5751 | iPar error Digital input filter time | Incorrect setting of parameter P805 Filter time |
| 5752 | iPar error Single/dual channel operation | Incorrect setting of parameter P800 I/O operating mode |
| 5753 | iPar error Input time discrepancy | Incorrect setting of parameter P803 Discrepancy time |
| 5754 | iPar error Passivation | Incorrect setting of parameter P801 Error response |
| 5755 | iPar error encoder parameter | Incorrect setting of parameters P810 Encoder , P811 Speed ratio or P813 Encoder resolution |
| 5756 | iPar error SLS activation | Incorrect setting of parameter P820 and/or P810 |
| 5757 | iPar error SSR activation | |
| 5758 | iPar error SDI-P activation | |
| 5759 | iPar error SDI-N activation | |
| 5761 | iPar error SOS activation | |
| 5762 | iPar error Activation time | Incorrect setting of parameter P821 Activation time |
| 5763 | iPar error Response time | Incorrect setting of parameter P822 Response time |
| 5764 | iPar error speed | Incorrect setting of parameter P823 Speed |
| 5765 | iPar error Tolerance | Incorrect setting of parameter P824 Max. position error |
| 5766 | iPar error Limit frequency | Incorrect setting of parameter P811 , P812 or P823 |
| 5771 | Temperature outside of specification | Excess temperature (system error) |
| 5772 | Encoder safety condition breached | Error at encoder connection (system fault) |
| 5773 | SYNC signal not "Low" | Bus interface synchronisation error (system error) |
| 5774 | Supply voltage error | The supply voltage is too high or too low |
| 5775 | Supply voltage error | The supply voltage is too high or too low |
| 5776 | Speed difference error | The difference between the speeds measured by the two processors is too high |
| 5781 | SLS error | The set SLS speed has been exceeded |
| 5782 | SSR error | The set SSR speed has been exceeded or undershot |
| 5783 | SDI_P error | The encoder has detected a negative direction |
| 5784 | SDI_N error | The encoder has detected a positive direction |
| 5785 | SOS error | Number of values counted by the encoder larger than the set tolerance |
| 5791 | System error saved in flash memory | The triggered system error is saved |
| 5792 | Maximum number of system errors | More than 15 system errors have occurred (replace bus interface) |
| 5797 | Flash memory access error | Flash memory access error cannot be saved |

Parameters

Frequency inverter: The following frequency inverter parameters must be adapted for setting up communication between the frequency inverter and the bus interface (for details please refer to the frequency inverter manual).

| Parameter [-Array] | Meaning | Remarks | |
|--|-----------------------------------|--|--------------|
| P120 [-01] | Option monitoring | "Auto" (default setting) | Only SK xU4 |
| P509 | Source Control Word | SK TU3-... on SK 5xxE: "Ethernet TU" SK xU4-... on SK 180/SK 2xxE: "System bus" | |
| P510 [-01]...[-02] | Setpoint source | "Auto" (default setting) | |
| P513 | Time-out | Monitoring of the SK TU3 bus interface | Only SK 5xxE |
| P543 [-01]...[-03] (-05) and P543...P545 | Bus actual value (1...3 (...5)) | Possible settings according to P418 | |
| P546 [-01]...[-03] (-05) and P546...P548 | Bus setpoint value (1...3 (...5)) | Possible settings according to P400 | |
| P700 [-01]/P701 | Current/last faults | Information parameter | |
| P740/P741 | Process data bus In / Out | Information parameter | |
| P745 | Module version | Information parameter | Only SK TU3 |
| P746 | Module status | Information parameter | Only SK TU3 |
| P748 | CANopen/System bus status | Information parameter | |

Bus interface: The bus interface provides a selection of appropriate parameters for setting or displaying special operating values. Parameters can be adapted using the NORDCON software or an SK PAR-3H / -3E parameter box. All parameters can still be read from and written to by the bus master via PROFINET IO.



| Parameter [-Array] | Meaning | Remarks | -TU3- | -TU4- | -CU4- |
|--------------------|---------------------------|--|-------|-------|-------|
| P150 | Set relays | Set DOUT directly or control via bus | | X | |
| P151 | External bus time-out | Monitoring of SK xU4 bus interface | | X | X |
| P152 | Factory setting | Reset bus interface parameters | X | X | X |
| P153 [-01 ...] | Minimum system bus cycle | Reduction of bus load on the system bus caused by the bus interface | | X | X |
| P154 [-01 ...] | Access to option card I/O | Administration of read and write permissions to the IOs of the bus interface | | X | X |
| P160 [-01...] | IP address | | X | X | X |
| P161 [-01...] | IP subnet mask | | X | X | X |
| P162 | Device name | Up to 240 characters (ASCII codes 45 ... 122), save by entering "0" as the final character | X | X | X |
| P163 [-01 ...] | Alarm test | Sets a diagnostic alarm | X | X | X |
| P164 [-01 ...] | IP Gateway | IP-Address for Gateway functionality | X | X | X |
| P170 [-01 ...] | Present errors | Indication of a bus interface error | X | X | X |
| P171 [-01 ...] | Software version | Firmware version/Revision | X | X | X |
| P172 | Configuration | Bus interface type | X | X | X |
| P173 [-01 ...] | Module status | Status of system bus or the connected FI | X | X | X |
| P174 | Status of digital inputs | Image of the switching status of DIN | | X | X |
| P175 | Digital output state | Image of the switching status of DOUT | | X | |
| P176 [-01...] | Process data bus In | Information parameter | X | X | X |
| P177 [-01...] | Process data bus Out | Information parameter | X | X | X |
| P178 | Internal temperature | Information parameter | | | X |
| P180 [-01 ...] | PPO Type | Information parameter | X | X | X |
| P181 [-01 ...] | MAC address | Information parameter | X | X | X |
| P185 [-01 ...] | Present IP address | Information parameter | X | X | X |
| P186 [-01 ...] | Current IP subnet mask | Information parameter | X | X | X |
| P187 [-01 ...] | Actual IP Gateway | Information parameter | X | X | X |
| P190 | Status DIP-switches | Information parameter | X | X | X |

Additional parameters for **PROFIsafe**

| Parameter [-Array] | Meaning | Remarks | -TU4- |
|--------------------|------------------------|---|-------|
| P800 [-01...] | I/O operating mode | Digital input/output operating mode: single or dual channel | X |
| P801 | Error response | Safe output response to an error | X |
| P802 [-01...] | Channel activation | Activate inputs and outputs | X |
| P803 | Discrepancy time | Permissible time difference for dual channel mode (→P800) | X |
| P804 | OSSD pulse | Pulse width for testing outputs | X |
| P805 | Filter time | Filter time for digital inputs SI1 and SI2 | X |
| P810 | Encoders | Activate encoder evaluation | X |
| P811 | Speed ratio | Set speed ratio "motor speed/encoder speed" (→P810) | X |
| P812 | Encoder resolution | Set encoder resolution | X |
| P820 [-01...] | Safety function | Switch safety functions On/Off | X |
| P821 [-01...] | Activation time | Safety function activation time (→P820) | X |
| P822 [-01...] | Response time | Reaction time of safety function (→P820) to an error | X |
| P823 [-01...] | Speed limit | Set the speed limit for safety functions (→P820) | X |
| P824 [-01...] | Max. position error | Set maximum position deviation for safety function | X |
| P830 | Save I parameter | Save settings P800...P824 in flash memory | X |
| P840 | I-parameter CRC | Display i parameter checksum (CRC) | X |
| P841 | Actual error | Display of the actual error present | X |
| P842 | Last error | Display last error | X |
| P843 | Software version | Display software version | X |
| P844 [-01...] | Temperature | Display actual temperature of bus interface | X |
| P845 [-01...] | Actual voltage | Display actual voltage of bus interface | X |
| P846 [-01...] | Status of DIP switches | Display DIP - switch settings | X |
| P847 | Speed | Display the speed measured by the encoder | X |
| P848 [-01...] | System error | Display system errors (incl. total number of errors) | X |

Parameter access and diagnostics

The NORD CON software and optional control units such as the SK PAR-3H parameter box provide convenient access to the parameters of the bus interface and allow status information to be read out.

| SK TU3- | SK TU4- | SK CU4- / SK TU4- |
|--|--|---|
| Access via RJ12 diagnostics socket of the SK 5xxE  | Access via RJ12 diagnostics socket of the bus connection unit SK TI4-TU-SAFE(-C)  | Access via RJ12 frequency inverter diagnostics socket, if connected to the bus interface via the system bus.  |

Further documentation and software (www.nord.com)

| Software | Description |
|----------------------------|---------------------------------------|
| GSDML-file | Device characteristics and parameters |

| Software | Description |
|--------------------------|---|
| NORD CON | Parametrisation and diagnostic software |

| Document | Description |
|-------------------------|-----------------------------------|
| BU 0000 | Description of NORD CON software |
| BU 0040 | Parameter box manual |
| BU 0200 | Frequency inverter manual SK 2xxE |

| Document | Description |
|------------------------------|--------------------------------------|
| BU 2800 | PROFsafe bus communication manual |
| TI 275280800 | Bus connection unit SK TI4-TU-SAFE-C |