

SK EBIOE-2

Part Number 275 900 210

IO Extension

Only qualified electricians are allowed to install and commission the module described below. An electrician is a person who, because of their technical training and experience, has sufficient knowledge with regard to

- Switching on, switching off, isolating, earthing and marking power circuits and devices,
- Proper maintenance and use of protective devices in accordance with defined safety standards.



DANGER

Danger of electric shock

The frequency inverter carries hazardous voltage for up to 5 minutes after being switched off.

- Work must not be carried out unless the frequency inverter has been disconnected from the voltage and at least 5 minutes has elapsed since the mains was switched off!

NOTICE

Validity of document

This document is only valid in conjunction with the operating instructions of the respective frequency inverter (📖 See overview at end of document). Safe commissioning of this module and the frequency inverter depends on the availability of this information.

Scope of Supply

1 x	Module	SK EBIOE-2
1 x	Snap-on rail bus connector	5-pole



Field of use

External IO extension for snap-on rail mounting of the **SK 54xE** (SK 1x0E, SK 2xxE also permissible). This can be connected to the inverter via the CAN bus. Four digital inputs, 2 digital outputs, 2 analog inputs and 1 analog output are available. Further IO modules can be connected via a snap-on rail bus connector.

Technical Information / Datasheet	SK EBIOE-2			
IO-Extension	TI 275900210	V 1.2	3517	en

Technical Data

Temperature range	0 °C ... 40 °C	Vibration resistance	2M1
Temperature class	Class 3K3	Firmware version	V1.3 R0
Protection class	IP20	Dimensions [mm]	HxWxD 114 x 22.5 x 105

Name	Terminal	Data
Module power supply (load capacity)	40/44	24 VDC \pm 20 %, reverse polarity protected (\leq 3 A)
Power consumption of module	40/44	140 mA ... 340 mA (according to load on terminal 43)
Digital input - provision of 24 VDC	40/43	\leq 200 mA (output)
Digital input - operating range	C1 ... C4	Low: 0 V ... 5 V, High: 15 V ... 30 V
Digital input - specific information	C1 ... C4	$R_i = 8,1 \text{ k}\Omega$, input capacitance: 10nF Scan rate 1 ms, reaction time 1 ms
Digital output - 24 VDC power supply	20/50	\leq 1000 mA (input)
Digital output - operating range	B1, B2	Low = 0 V, High = 24 V; max. 500 mA
Analog input - reference voltage	11	10 VDC \pm 0,1 V, \leq 20 mA (output)
Analog input - differential input version	13/14; 15/16	Resolution: 12 Bit, accuracy: 0.1 V, Load resistance 250 Ω (Connection via DIP switch when configuration as a current input.)
Analog input - load capacity	13/14; 15/16	\leq 10 mA (mode: 0/2 ... 10 V) \leq 20 mA (mode: 0/4 ... 20 mA)
Analog output - load capacity	17	\geq 1 k Ω (Mode: 0/2 ... 10 V) \leq 250 Ω (Mode: 0/4 ... 20 mA)
Analog output - specific information	17	Resolution: 10 Bit, accuracy: 0.25 V
RJ45 - current capacity	RJ45 7/8	\leq 1200 mA

Installation

Installation location	Inside a suitable switching cabinet
Mounting	Mounting on snap-on rail (TS 35)

Connections

Terminals	Screw terminals	6 terminal blocks, each with 4 connections, (5 mm spacing)
Cable cross section	0,14 ... 2,5 mm	AWG 14-26
PE connection	via snap-on DIN rail	The snap-on rail must be earthed
Snap-on rail bus connector	Plug connector	For the serial installation of up to 8 SK EBIOE-2 modules
RJ45	RJ45 - socket	For connection via RJ45 connection cable

Terminal	Contact	Designation	Description
X1 Top position	40	GND/0V	Reference potential (0 V / GND)
	44	VI 24V	Supply voltage (+24 V - in)
	78	SYS-	System bus data cable -
	77	SYS+	System bus data cable +
X2 Top position	12	AGND/0V	Analog Ground (internally connected to terminal 40)*
	15	AIN2-	Analog input 2, negative
	16	AIN2+	Analog input 2, positive
	17	AOUT	Analog output
X3 Top position	12	AGND/0V	Analog Ground (internally connected to terminal 40)*
	13	AIN1-	Analog input 1, negative
	14	AIN1+	Analog input 1, positive
	11	VO 10V	10 V Reference voltage
X4 Bottom position	50	VI 24V2	Supply voltage (+24 V - in) for digital outputs
	B1	DOUT1	Digital output 1
	B2	DOUT2	Digital output 2
	20	GND2/0V2	Reference potential (0 V / GND) of digital outputs
X5 Bottom position	43	VO 24V	Supply voltage for digital inputs (+24 V - out)
	C3	DIN3	Digital input 3
	C4	DIN4	Digital input 4
	40	GND/0V	Reference potential (0 V / GND)
X6 Bottom position	43	VO 24V	Supply voltage for digital inputs (+24 V - out)
	C1	DIN1	Digital input 1
	C2	DIN2	Digital input 2
	40	GND/0V	Reference potential (0 V / GND)
X7 Front position	RJ45 - 1	SYS +	System bus data cable +
	RJ45 - 2	SYS -	System bus data cable -
	RJ45 - 7	GND/0V	Reference potential (0 V / GND)
	RJ45 - 8	24 V	Supply voltage (+24 V - in / out)
X8 Rear position	Snap-on rail bus connector		Connection of voltage supply and system bus to a further SK EBIOE-2 module

* AGND/0V is internally connected to the reference voltage of the module GND/0V via a special component. In order to prevent damage to the module or faults in the analog signals, the two contacts must not be bridged

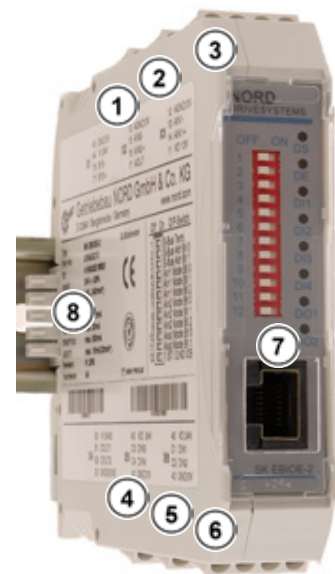

1 ... 8 = X1 ... X8

NOTICE

Load on the RJ45 socket

The load on the contacts of the RJ45 socket must not exceed 1.2 A. When setting up a correspondingly large network with frequency inverters and IOE modules, it may be necessary to set up two circuits in order to prevent overload.

Schematic circuit diagram of electrical connection

(Terminal designations in example) Frequency inverter SK 54xE

Terminal	Function	Device
X1	Supply / System bus	SK EBIOE-2
X2	AIN 2 / AOUT	
X3	AIN 1	
X4	DOUT	
X5	DIN 3 / 4	
X6	DIN 1 / 2	
X7	Supply / System bus	
X8	Supply / System bus	
X9	Supply / System bus	SK 54xE
X10	Supply / System bus	SK 54xE
RJ45 WAGO connection module Part. No.: 278910300		

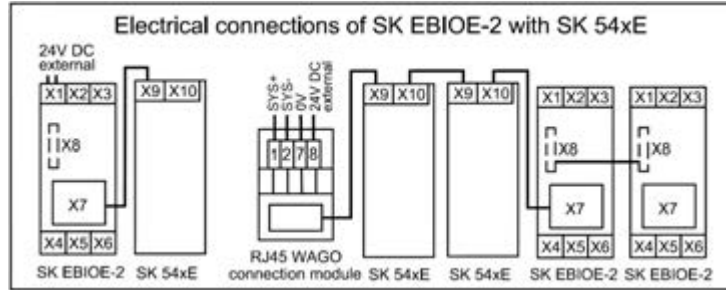

Connection examples

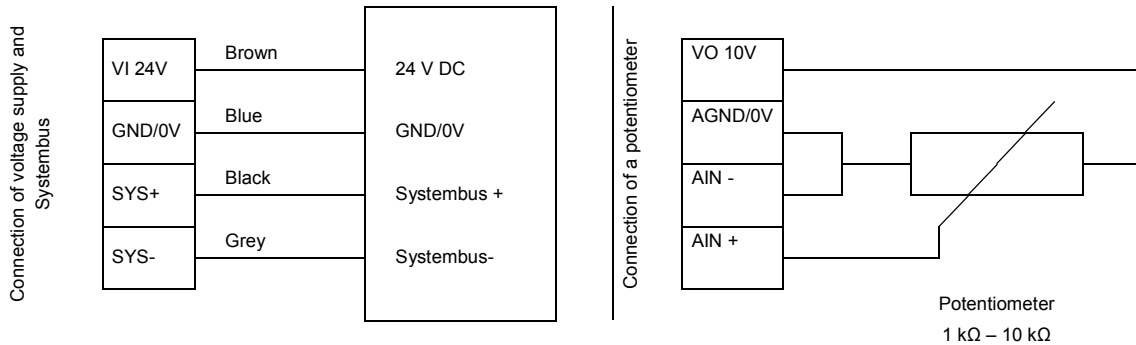

Configuration

Configuration of the module is mainly performed via the DIP switches. The DIP switches are read after a "power on" of the module. A change to the DIP switch during operation has no effect.

The system bus must be terminated at both of its physical ends (if necessary set the "System bus termination resistor" DIP switch).



Note

Broadcast mode

In "Broadcast mode, which is activated via the parameter (**P162**), the module can access up to 4 inverters in parallel. Therefore the frequency inverters jointly access the I/Os and evaluate the input signals according to their own parameterisation. Output signals from the frequency inverters which are sent to the common IO module are linked by a logical "OR" within the module. i.e. a digital output is set as soon as one of the four frequency inverters addresses it. In addition, the highest analog value is provided via the analog output of the IO extension.

DIP switches

Function	DIP-Switch Meaning (DIP-No.)	DIP-Switch Combinations			Assignment Signal
		BIT2	BIT1	BIT0	
System bus termination resistor	S-Bus Term. (01)			0 1	not set setting
Addressing system bus	S-Bus Adr. Bit 0 (02)		0 0	0 1	Adr. 20 (for FI 0 Adr. 32)* Adr. 21 (for FI 1 Adr. 34)*
	S-Bus Adr. Bit 1 (03)		1 1	0 1	Adr. 22 (for FI 2 Adr. 36)* Adr. 23 (for FI 3 Adr. 38)*
Analog input AIN1	Ain1 Mode Bit 0 (04)	0 0	0 0	0 1	0 ... 10 V 2 ... 10 V
	Ain1 Mode Bit 1 (05)	0 1	1 0	0 0	-10 ... 10 V 0 ... 20 mA
	Ain1 Mode Bit 2 (06)	1	0	1	4 ... 20 mA
Analog input AIN2	Ain2 Mode Bit 0 (07)	0 0	0 0	0 1	0 ... 10 V 2 ... 10 V
	Ain2 Mode Bit 1 (08)	0 1	1 0	0 0	-10 ... 10 V 0 ... 20 mA
	Ain2 Mode Bit 2 (09)	1	0	1	4 ... 20 mA
Analog output AOUT	Aout Mode Bit 0 (10)		0 0	0 1	0 ... 10 V 2 ... 10 V
	Aout Mode Bit 1 (11)		1 1	0 1	0 ... 20 mA 4 ... 20 mA
Mode Second - IOE	2nd IOE Mode (12)			0 1	First SK-...-IOE on FI Second SK-...-IOE on FI

* With DIP12 = ON: Address 10 ... 13 instead of 20 ... 23

LED Displays

DS (Device State)	DE (Device Error)	Meaning
		Long flashing = 0.5 s on / 1 s off Short flashing = 0.25 s on / 1 s off
OFF	OFF	Technology unit not ready, no control voltage
ON	OFF	Technology unit ready, no error, at least one frequency inverter is communicating via the system bus
ON	Short flashing	Technology unit ready, however <ul style="list-style-type: none"> One or more of the connected frequency inverters is in fault status
Long flashing	OFF	Technology unit ready and at least one further participant is connected to the system bus, but <ul style="list-style-type: none"> No frequency inverter on the system bus (or connection interrupted) Address error for one or more system bus participants
Long flashing	Short flashing Flash interval 1 x - 1s pause	System bus is in status "Bus Warning" <ul style="list-style-type: none"> Communication on system bus interrupted or No other participant present on the system bus
Long flashing	Short flashing Flash interval 2 x - 1s pause	<ul style="list-style-type: none"> System bus is in status "Bus off" or The system bus 24V power supply was interrupted during operation
Long flashing	Short flashing Flash interval 3 x - 1s pause	<ul style="list-style-type: none"> No system bus 24V power supply (system bus is in status "Bus off")
Long flashing	Short flashing Flash interval 4 x - 1s pause	Module error <ul style="list-style-type: none"> EEPROM error
Long flashing	Short flashing Flash interval 5 x - 1s pause	Module error <ul style="list-style-type: none"> AOUT error (analog output) DIP switch configuration error
OFF	Short flashing Flash interval 1...7 - 1s pause	System error, internal program sequence interrupted <ul style="list-style-type: none"> EMC interference (observe wiring guidelines!) Module faulty

IO channel	Display	Meaning
DI 1	ON	High potential DIN1
DI 2	ON	High potential DIN2
DI 3	ON	High potential DIN3
DI 4	ON	High potential DIN4

IO channel	Display	Meaning
DO 1	ON	High potential DOUT1
DO 2	ON	High potential DOUT2

DI 3/4, DO 1/2 Available according to the type of IO module

Error messages

Error messages for the module - the present or archived messages for the last error - can be read out via the module parameter (P170).

Error	Meaning	Comments
1000	EEPROM error	EMC fault, module defective
1030	System bus OFF	No 24 V supply to bus, connections not correct
2000	DIP switch changed	DIP switch configuration changed during operation
2001	DIP switch configuration incorrect	Invalid DIP switch settings
2010	Error at analog output	Overload, reference voltage, short-circuit, calibration error
2020	Inverter does not support the module	Incorrect inverter type connected

Parameterisation

Inverter: In order to establish communication between the inverter and the IOE module, the following inverter parameters must be changed.

Parameter	Meaning	Comments
(P514)	Bus speed	5 (= 250 kBaud)
(P515 [-01])	Bus address	FI 1 = 32 FI 2 = 34 FI 3 = 36 FI 4 = 38
(P480 [-01 ...])	DIN function of the device	Possible settings according to (P420)
(P481 [-05 ...])	DOUT function of the device	Possible settings according to (P434)
(P400 [-03 ...])	AIN function of the device	Possible settings according to (P400)
(P418 [-01 ...])	AUT function of the device	Possible settings according to (P418)

IO extension: The module provides a selection of parameters for setting or displaying special operating values. The parameters can be changed with the aid of the NORD CON-software or with a ParameterBox. Communication is only possible via an SK 54xE, SK 2xxE or SK 1x0E which is connected to the module.

Parameter	Meaning	Comments
(P150)	Set relays	Set DOUT directly or control via BUS
(P152)	Factory setting	Reset the module parameters, calibrate AOOUT
(P153 [-01 ...])	Minimum system bus cycle	Reduction of bus load due to the module
(P160 [-01 ...])	Set analog output	Set AOOUT directly or control via BUS
(P161 [-01 ...])	Filter time	Debounce or round input signals
(P162)	Send broadcast	Activate Broadcast mode (control of several inverters by this module)
(P163 [-01 ...])	Invert analog output	Invert analog signal
(P170 [-01 ...])	Present errors	Display of module errors
(P171 [-01 ...])	Software version	Firmware version / Revision
(P172)	Configuration	Module type
(P173)	Module status	Status of system bus or connected FI
(P174)	Status of digital inputs	Display of DIN switching status
(P175)	Relay status	Display of DOUT switching status
(P176 [-01 ...])	Actual voltage	Voltage level of analog signals

Further documentation and software (www.nord.com)

Software	Name
NORD CON	Parameterisation and diagnostic software

Software	Name

Document	Name
BU_0000	Description of NORD CON software
BU_0040	ParameterBox manual
BU_0180	Frequency inverter manual SK 180E, SK 190E

Document	Name
BU_0200	Frequency inverter manual SK 2xxE
BU_0505	Frequency inverter manual SK 54xE

Description of parameters

P150		Set relays	
Setting range	0 ... 4	Other applicable parameter(s) P480	
Factory setting	{ 0 }		
Scope of Application	SK CU4-IOE2, SK TU4-IOE, SK EBIOE-2		
Description	Sets the switching states of the digital outputs		
Setting values	Value	Meaning	
	0	Via bus	Control of all digital outputs via the system bus; the functions are defined in the frequency inverter (P480).
	1	Outputs OFF	All digital outputs are Off (Low = 0 V).
	2	Output 1 on (DO1):	The digital output DO1 is set to "High" (active); digital output DO2 remains switched off.
	3	Output 2 ON (DO2)	The digital output DO2 is set to "High" (active); digital output DO1 remains switched off.
	4	Outputs 1 and 2 ON	All digital outputs are on (High)
P152		Factory setting	
Setting range	0 ... 2		
Factory setting	{ 0 }		
Description	Resets the module parameters to the factory settings.		
Note	On completion of this process the parameter display changes back to the value "0"		
Setting values	Value	Meaning	
	0	No change	This function is not implemented.
	1	Load factory setting	All parameters are reset to the factory settings.
	2	Calibration AOut	The accuracy of the analog output can be improved with a correction line, however, this is not activated as standard. If factory settings (P152 ={ 1 }) are loaded, the correction values are retained. A calibration is carried out if (P152) is set to { 2 }, i.e. the line is re-recorded and stored in the EEPROM.
P153		Minimum system bus cycle	
Setting range	5 ... 250 ms		
Arrays	[-01] = TxSDO Inhibit Time	[-02] = TxPDO Inhibit time	
Factory setting	{ [-01] = 10 }	{ [-02] = 5 }	
Description	Adjusts the cycle time for transmission of SDOs (Service Data Objects) and PDOs (Process Data Object) on the system bus.		
Note	Increasing the cycle time reduces the bus load		

P160		Set analog output	
Setting range	-0,1 ... 10,0 V		
Arrays	[-01] = Analog output 1		[-02] = Analog output 2
Factory setting	{ [-01] = -0.1 }		{ [-02] = -0.1 }
Description	Sets the signal to a defined value, independent of the system bus.		
Note	<p>If the analog output is configured as an output for current values, the factor 2 must be considered.</p> <p>The setting 0 V corresponds in this case to a current value of 0 mA ($0 \times 2 = 0$).</p> <p>The setting 10 V corresponds in this case to a current value of 20 mA ($10 \times 2 = 20$).</p> <p>The arrays are only functional if the corresponding IOs are present in the module.</p>		
Setting values	Value	Meaning	
	-0.1	The value is set via Bus	
	0.0 ... 10.0	The value is set manually	
P161		Filter time	
Setting range	0 ... 400 ms		
Arrays	[-01] = Analog input 1		[-02] = Analog input 2
	[-03] = Analog output 1		[-04] = Digital input 1
	[-05] = Digital input 2		[-06] = Digital input 3
	[-07] = Digital input 4		[-08] = Digital output 1
	[-09] = Digital output 2		[-10] = Analog output 2
Factory setting	{ [-01], [-02] = 100 }		{ [-04] ... [-07] = 2 } { [-03], [-08] ... [-10] = 0 }
Description	<p>The analog and digital inputs are read cyclically every 250 μs, which results in an input uncertainty of 0.25ms. In order to eliminate bounce and smooth the input signals, the information which is read in is passed through a filter routine. The filter time can be parametrised.</p> <p>For example, if a filter time of 1 ms is parametrised for a digital input, the input signal is delayed by approx. 1...1.25ms.</p> <p>The parameterisation of the filter time for the analog outputs is used to round off signal jumps.</p>		
Note	The arrays are only functional if the corresponding IOs are present in the module.		
P162		Send broadcast	
Setting range	0 ... 1		
Factory setting	{ 0 }		
Description	<p>Activates the broadcast mode.</p> <p>In broadcast mode, up to four frequency inverters can access the module simultaneously.</p>		
Note	<p>In broadcast mode, the addressing of the module (DIP switches) is no longer taken into account.</p> <p>The received data are linked in the I/O module using OR logic. If several frequency inverters are linked to the digital outputs of the module, the relevant output is set to "High" as soon as it is accessed by a frequency inverter. The analog outputs behave in a similar manner. Here, the highest value has priority.</p>		
Setting values	0 = Off		1 = On (broadcast mode active)

P163	AOut Inverse	
Setting range	0 ... 1	
Arrays	[-01] = Analog output 1	[-02] = Analog output 2
Factory setting	{ 0 }	
Description	Inverts the signal at the analog output.	
Note	The arrays are only functional if the corresponding IOs are present in the module.	
Setting values	0 = Off	1 = On (inversion active)
P170	Actual error	
Display range	0.0 ... 564.0	
Arrays	[-01] = Actual error	Active error message (not acknowledged)
	[-02] = Last fault	Displays the last error message from the error memory
Description	Displays an error message.	
Note	SK CSX-3... The display is encoded SK PAR-3... The display is in plain text	
Display values	📖 Section "Error messages"	
P171	Software version	
Display range	0.0 ... 9999.0	
Arrays	[-01] = Software version	Version number (e.g.: V1.0)
	[-02] = Software revision	Revision number (e.g.: R1)
	[-03] = Special version	Special version of the hardware/software (e.g: 0.0). The value "0" stands for "Standard Version".
Description	Displays the software version (firmware version) of the module	
P172	Configuration	
Display range	0 ... 8	
Description	Displays the configuration / version of the device	
Display values	Value	Meaning
	0	CU4 (internal) Module type: SK CU4-...
	1	TU4 (external) Module type: SK TU4-...
	2	TU1-3 (Techn. Unit) Module type: SK TU1- / TU2- / TU3- ...
	3	TU1-3 (Techn. Unit)+DIP Module type: SK TU1- / TU2- / TU3- ... with DIP-switches
	4	EBIOE-2 Module type: SK EBIOE-2
	5	TU4 Safe Module type: SK TU4-... / "Safe" version
	6	TU3 Safe Module type: SK TU3-... / "Safe" version
	7	CU4IOE-2 Module type: SK CU4-IOE2-...

P173		Option status																	
Display range	0000 ... FFFF <small>(hex)</small>																		
Description	Displays the status of the connected devices and the system bus																		
Note	SK CSX-3... The display is in hexadecimal format SK PAR-3... The display is in binary format																		
Display values	Value (Bit)		Meaning																
	0	... 5	Not used																
	6	BUS WARNING	System bus is in status "BUS WARNING"																
	7	BUS OFF	System bus is in status "BUS OFF"																
	8	FI 1 (Low – Bit)	FI 1 status (low Bit)	<table border="1"> <thead> <tr> <th>Bit High</th> <th>Bit Low</th> <th>Meaning</th> </tr> </thead> <tbody> <tr> <td>0</td> <td>0</td> <td>FI is offline</td> </tr> <tr> <td>0</td> <td>1</td> <td>FI is not recognised</td> </tr> <tr> <td>1</td> <td>0</td> <td>FI is online</td> </tr> <tr> <td>1</td> <td>1</td> <td>FI lost</td> </tr> </tbody> </table>	Bit High	Bit Low	Meaning	0	0	FI is offline	0	1	FI is not recognised	1	0	FI is online	1	1	FI lost
Bit High	Bit Low	Meaning																	
0	0	FI is offline																	
0	1	FI is not recognised																	
1	0	FI is online																	
1	1	FI lost																	
	9	FI 1 (High – Bit)	FI 1 status (High Bit)																
	10	... 11	FI 2 status																
	12	... 13	FI 3 status																
	14	... 15	FI 4 status																

* FI is switched off

P174		Status of digital in.		
Display range	0000 ... 1111 <small>(bin)</small>			
Description	Actual image of the switching states of the digital inputs.			
Note	SK CSX-3... The display is in hexadecimal format SK PAR-3... The display is in binary format			
Display values	Value (Bit)		Meaning	
	0	Digital input 1	Digital input 1 of the module	
	1	Digital input 2	Digital input 2 of the module	
	2	Digital input 3	Digital input 3 of the module	
	3	Digital input 4	Digital input 4 of the module	

P175		State of relays		
Display range	00 ... 11 <small>(bin)</small>			
Description	Actual image of the switching states of the digital outputs.			
Note	SK CSX-3... The display is in hexadecimal format SK PAR-3... The display is in binary format			
Display values	Value (Bit)		Meaning	
	0	Relay 1	Digital output 1 of the module	
	1	Relay 2	Digital output 2 of the module	

P176		Current voltage		
Display range	-10,0 ... 10,0 V			
Arrays	[-01] = Analog input 1		[-02] = Analog input 2	
	[-03] = Analog output 1		[-04] = Analog output 2	
Description	Shows the measured voltage.			