

GETRIEBEBAU NORD

Member of the NORD DRIVESYSTEMS Group

Getriebebau NORD GmbH & Co. KG

Getriebebau-Nord-Straße 1 • 22941 Bargteheide, Germany • www.nord.com



SK BR2-3/17000-C

Part number: 278 282 754

External chassis braking resistor for connection to a NORDAC PRO SK 500E



It only is allowed for qualified electricians to install and commission the module. An electrician is a person who, because of their technical training and experience, has sufficient knowledge relating to

- switching on, switching off, isolating, earthing and marking power circuits and devices,
- proper maintenance and use of protective devices in accordance with defined safety standards.

DANGER!

Danger of electric shock

The frequency inverter continues to carry hazardous voltages for up to 5 minutes after it was switched off.

- Work must not be carried out unless the device has been disconnected from the voltage and at least 5 minutes have elapsed since the mains was switched off!

CAUTION

Danger of burns

The module and all other metal components can heat up to temperatures above 70 °C.

- Sufficient cooling time must be allowed for when working on the components in order to avoid injuries (local burns) to parts of the body coming into contact with the components.
- In order to avoid damage to neighbouring objects, sufficient clearance must be maintained during installation.

NOTICE

Validity of this document

This document is only valid in combination with the operating instructions for the relevant frequency inverter. Safe commissioning of this module and the frequency inverter depends on the availability of this information.

Technical Information / Datasheet	SK BR2-3/17000-C			
Brake resistor	TI 278282754	1.0	4520	en

Scope of delivery

Module		
1 x	Braking resistor	Incl. connection terminals



Field of use

Dynamic braking (frequency lowering) of a three-phase motor via a frequency inverter results in generator braking energy that – depending on the particular application – is dissipated by a braking resistor. This excess energy is converted into heat.

The braking resistor is designed for the NORDAC *PRO* SK 500E series of units and depends on the mains voltage and the power. The braking resistor is equipped with a temperature switch and a potential-free normally closed contact for temperature monitoring.



Technical Data
Electrical data

Number of terminals		4
Resistance	Ω	3
Max. continuous power P_n	W	17000

¹⁾ The stated value applies to a single use within 120 s.

Short-time power P_{max 1)}		
for 1.2 s	kW	510.0
for 7.2 s	kW	161.0
for 30 s	kW	54.0
for 72 s	kW	25.0

General

Temperature range	°C	0 ... 40 (100% ED/S1)
Weight	kg	≈ 17.5

Approvals	CE, RoHS, cURus
Protection class	IP20
Mounting ¹⁾	
Screws	4 x M8 x 16 (mounting surface)

¹⁾ Not included in the scope of delivery

Dimensions

Overall dimensions [mm]	W x H x D	595 x 270 x 490
Fastening [mm]	A / 380	570 x 380

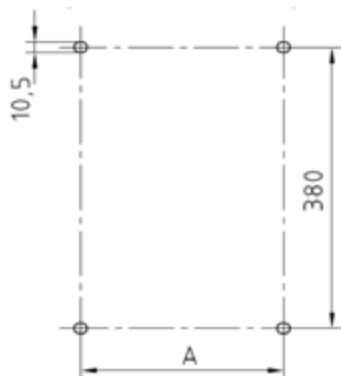
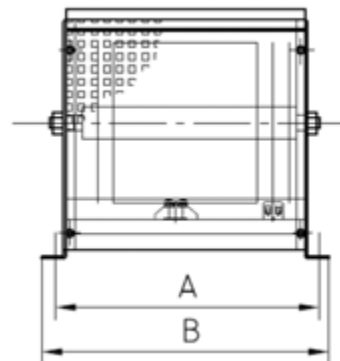
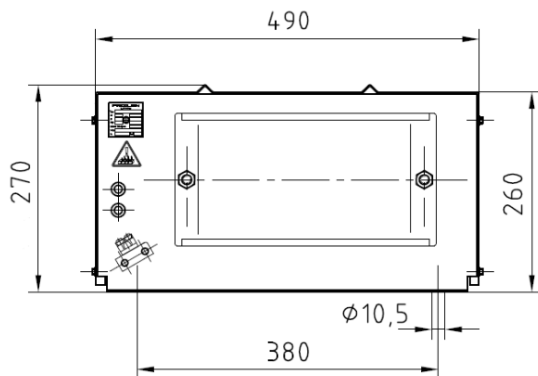
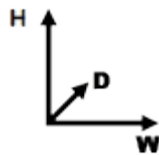
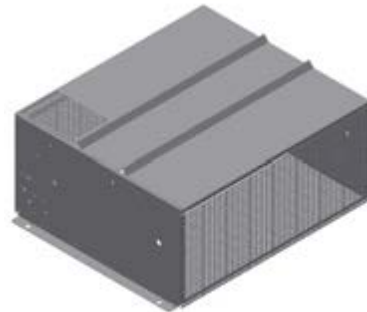

Information

Temperature monitoring

For connection of the external braking resistor to the NORDAC *PRO* SK 5xxE a temperature switch is available for temperature monitoring. The normally closed contact T1/T2 is connected via a free digital input of the frequency inverter. We recommend to parametrise the digital input with the *Voltage Disable* function.

Switching power of the normally closed contact:

- 2 A at 24 V DC
- 2 A / 230 V AC

Detailed information can be found in the manual, Chapter  "Further documentation and software www.nord.com".

Connections

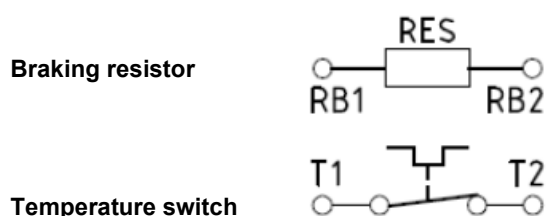

Resistance

Designation	RB1	RB2
Cross section / type	M6 / bolt	
Terminals	Stud terminal BK M6	
Braking resistor		
Frequency inverter terminal block X2	+ B	-B
Tightening torque	3.0 Nm	
Braking resistor		
Frequency inverter SK 5xxE	15.0 Nm	

Temperature switch



Designation	T1	T2
Cross section / type	AWG 18/14 / screw terminals	
Terminals	Porcelain terminal block PK	
Braking resistor		
Frequency inverter terminal block X5	Voltage supply	Digital input
Tightening torque	0.5 Nm	
Braking resistor		

Assignment to frequency inverters

Information

Overview in the manual



The braking resistors provided by the NORD DRIVESYSTEMS Group are tailored to the individual frequency inverters. If external braking resistors are used, it is usually possible to choose between 2 or 3 alternatives.



Detailed information can be found in Chapter  Braking Resistor (BR) of the respective frequency inverter manual  "Further documentation and software www.nord.com".

Installation

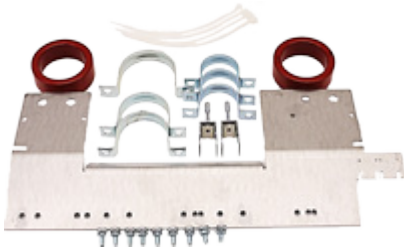
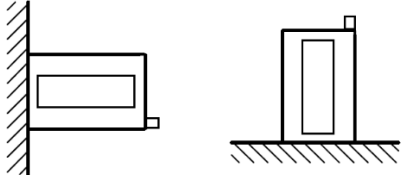
Installation location	Direct installation with connection cables that are provided for connection to a centralised NORDAC <i>PRO</i> frequency inverter: <ul style="list-style-type: none"> In the vicinity of the frequency inverter within the control cabinet
Mounting position	In horizontal position on vertical mounting surfaces with terminals facing down
Mounting	With screw fasteners <ul style="list-style-type: none"> Screws for mounting are not included in the scope of delivery

Installation steps

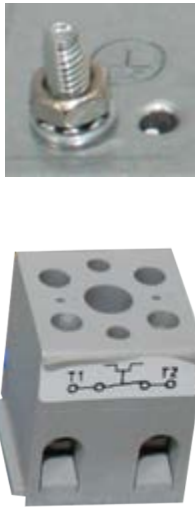
1.	<p>Installing the frequency inverter</p> <p>The SK 5xxE of size 11 is already mounted to the mounting surface.</p>	
2.	<p>Installing the EMC kit</p> <p>SK 5xxE frequency inverters must be equipped with an EMC kit SK EMC 2-7 (Part No. 275999071) for correct EMC connection. The shield of the braking resistor cable can be connected to a large area of the frequency inverter via the shielding terminal.</p> 	
3.	<p>Installing the external chassis braking resistor</p> <p>The braking resistor must be mounted correctly on the wall or the mounting surface close to the frequency inverter in vertical position with the 4 fastening screws which are provided.</p>	 <p style="text-align: center;">Permissible Not permissible</p>
4.	<p>Connection cable (BR + TS)</p> <p>Connect braking resistor to the frequency inverter via two connection cables that are provided.</p> <ul style="list-style-type: none"> Connect one open wire end/shield of the shielded connection cable via EMC shielding terminal or clamp to the shield angle of the frequency inverter Fasten connection cable properly and connect on both sides Connect the connection cable shield with regard to EMC compliance <p>Comply with specified tightening torques (see  Technical Data – General).</p>	

<p>5.</p>	<p>Connection to braking resistor Connect wires of the BW connection cable to the corresponding terminal block of the braking resistor.</p> <ol style="list-style-type: none"> ① Green/yellow wire/ PE ⇔ M6 bolt ② Wire 1 ⇔ RB1 ③ Wire 2 ⇔ RB2 <p>Connect wires of the TS connection cable to the corresponding terminal block of the braking resistor.</p> <ol style="list-style-type: none"> ④ Wire 1 ⇔ T1 ⑤ Wire 2 ⇔ T2 																						
<p>6.</p>	<p>Connection of the BR connection cable to the frequency inverter Use cable lugs to connect wires from the other end of the BR connection cable at the front side of the frequency inverter to the terminal block X30 (M8 bolt).</p> <table border="0"> <tr> <td>Shield</td> <td>EMC kit</td> <td>Shield angle/ shielding terminal</td> </tr> <tr> <td>Ground cable</td> <td>PE</td> <td></td> </tr> <tr> <td>Wire 1</td> <td>B-</td> <td></td> </tr> <tr> <td>Wire 2</td> <td>B+</td> <td></td> </tr> </table> <p>Connection of the TS connection cable to the frequency inverter Connect wires from the other end of the TS connection cable at the signal terminal strip of the frequency inverter to the terminal block X5.</p> <table border="0"> <tr> <td>Shield</td> <td></td> <td>Shield angle/ shielding terminal</td> </tr> <tr> <td>Wire 1</td> <td>Digital input</td> <td></td> </tr> <tr> <td>Wire 2</td> <td>Voltage supply</td> <td></td> </tr> </table>	Shield	EMC kit	Shield angle/ shielding terminal	Ground cable	PE		Wire 1	B-		Wire 2	B+		Shield		Shield angle/ shielding terminal	Wire 1	Digital input		Wire 2	Voltage supply		
Shield	EMC kit	Shield angle/ shielding terminal																					
Ground cable	PE																						
Wire 1	B-																						
Wire 2	B+																						
Shield		Shield angle/ shielding terminal																					
Wire 1	Digital input																						
Wire 2	Voltage supply																						

Parameters

Frequency inverter: The following parameters of the frequency inverter have to be set for optimum brake resistor operation. Refer to the frequency inverter manual for details  "Further documentation and software www.nord.com".

Parameters	Meaning	Remarks
P556	Braking resistor	Value of the brake resistance for the calculation of the maximum brake power to protect the resistor. <ul style="list-style-type: none"> The error I²t limit (E003.1) is triggered. Further details  in P737.
P557	Braking resistor type	Continuous power (nominal power) of the resistor, to display the actual utilisation in P737. For a correctly calculated value, the correct value must be entered into P556 and P557. <ul style="list-style-type: none"> 0.00 = Off, monitoring disabled
P737	Usage rate brake res.	This parameter provides information about the actual degree of modulation of the brake chopper or the current utilisation of the braking resistor in generator mode. <ul style="list-style-type: none"> Depending on the settings of parameters P556 and P557. The resistance power is displayed if both parameters are set correctly.

Error messages

Error messages from the braking resistor - the current or archived message for the last fault - can be read out from the information parameter Current Fault P700 and the Last Fault P701 in the error memory of the frequency inverter. Refer to the frequency inverter manual for details  "Further documentation and software www.nord.com".

Error (E030/E050)	Meaning	Remarks
3.1	I ² t overcurrent limit	Brake chopper: I ² t limit has been triggered, 1.5-fold value for 60 s reached ( P556, P557) <ul style="list-style-type: none"> Avoid overcurrent in brake resistance
5.0	Overvoltage UZW	Link circuit voltage too high <ul style="list-style-type: none"> Check the function of the connected braking resistor (broken cable) Resistance value of connected braking resistor too high

Connection diagram

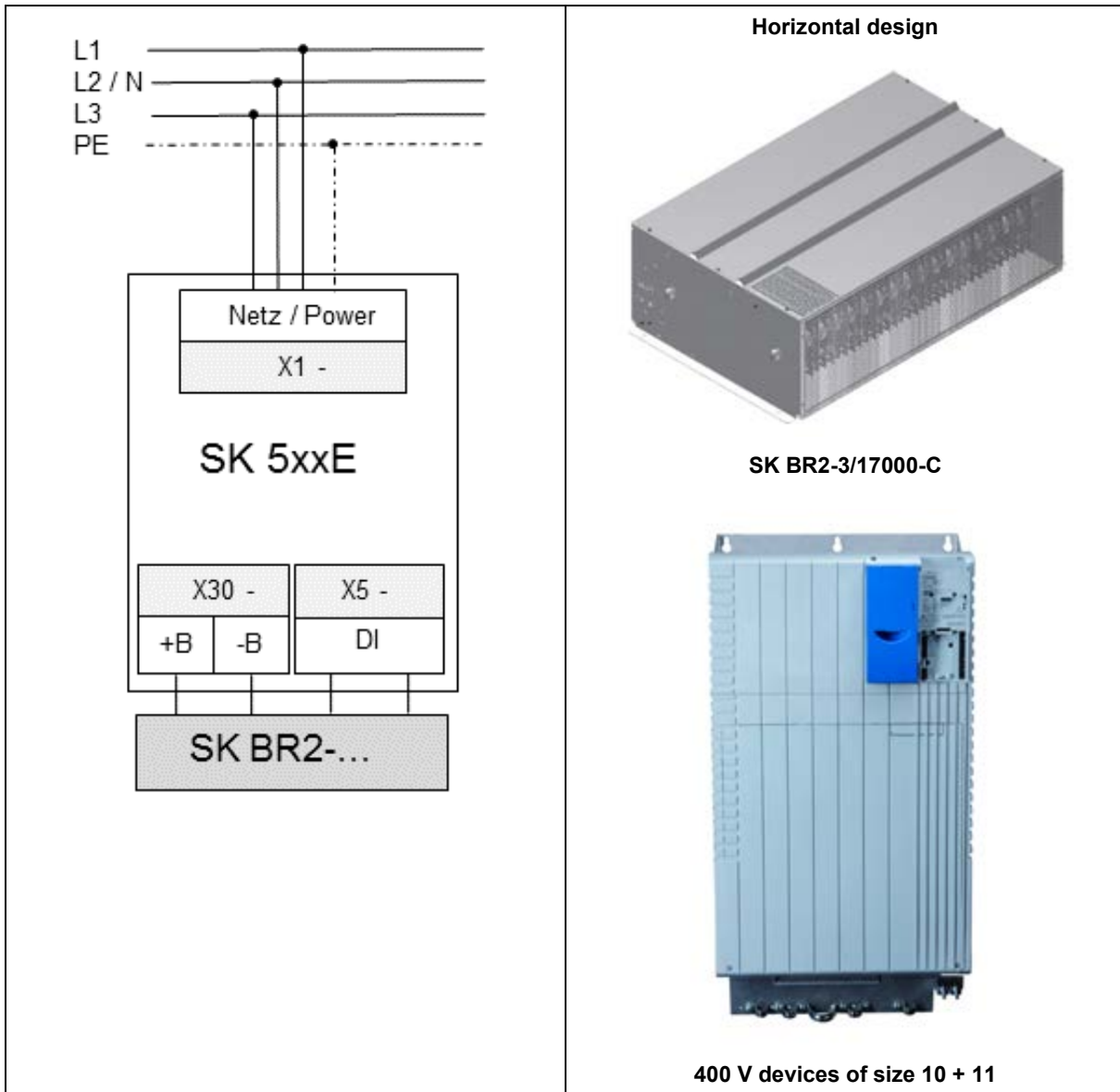

Further documentation and software www.nord.com

Document	Designation
BU_0500	Frequency inverter manual SK 500E – SK 535E
BU_0505	Frequency inverter manual SK 54xE
BU_0600	Frequency inverter manual SK 500P – SK 550P
F3050_E3000	Flyer NORDAC PRO SK 500E